

ITEM NUMBER: 71100
ISSUED: APRIL 19, 1993
REVISED: APRIL 26, 2001



HOSHIZAKI STORAGE BIN

MODEL B-250PD
B-300PD
B-500PD
B-700PD
B-800PD
B-900PD

PARTS LIST

B-250PD	G-0	May, 1997
	H-0	Dec., 1997
	J-0	March, 1999
	K-0	March, 2000
B-300PD	C-1	Feb., 1993
	D-0	April, 1994
	E-0	Dec., 1994
	E-1	May, 1995
	F-0	Dec., 1995
	G-0	Dec., 1996
	H-0	Dec., 1997
	J-0	Dec., 1998
	K-0	Dec., 1999
B-500PD	C-1	March, 1993
	D-0	Dec., 1993
	E-0	Jan., 1995
	E-1	June, 1995
	F-0	Dec., 1995
	G-0	Dec., 1996
	H-0	Dec., 1997
	J-0	Dec., 1998
	K-0	Dec., 1999
B-700PD	D-1	Jan., 1994
	E-0	Nov., 1994
	E-1	June, 1995
	F-0	Dec., 1995
	F-1	Jan., 1996
	G-0	Dec., 1996
	H-0	Dec., 1997
	J-0	Dec., 1998
	K-0	Dec., 1999
B-800PD	D-1	Jan., 1994
	D-0	Nov., 1994
	E-1	June, 1995
	F-0	Dec., 1995
	F-1	Jan., 1996
	G-0	Dec., 1996
	H-0	Dec., 1997
	J-0	Dec., 1998
	K-0	Dec., 1999
B-900PD	D-1	Feb., 1994
	E-0	Nov., 1994
	E-1	June, 1995
	F-0	Dec., 1995
	F-1	Jan., 1996
	G-0	Dec., 1996
	H-0	Dec., 1997
	J-0	Dec., 1998
	K-0	Dec., 1999

FASTENER ABBREVIATION LIST

ST	Phillips Truss Machine Screw
SP	Phillips Pan Head Machine Screw
SF	Phillips Flat Head Machine Screw
SS	Phillips Pan Head Machine Screw with Split Lock Washer
SW	Phillips Pan Head Machine Screw with Split Lock Washer and Flat Washer
T1	Phillips Truss Head Tapping Screw (Correspond to Type A)
T2	Phillips Truss Head Tapping Screw (Correspond to Type B)
T3	Phillips Truss Head Tapping Screw (Correspond to Type C)
FT	Phillips Truss Head Tapping Screw (Special)
BH	Hexagon Head Bolt
BC	Socket Head Cap Screw
BS	Hexagon Bolt with Split Washer
BW	Hexagon Bolt with Split Washer and Flat Washer
BF	Hexagon Flange Bolt
BR	Cross-Recessed Hexagon Head Bolt
BRW	Cross-Recessed Hexagon Head Bolt with Split Lock Washer and Flat Washer
WL	Split Lock Washer
WT	External Tooth Washer
WF	Flat Washer
WS	Spring Washer
NH	Hexagon Nut
NF	Hexagon Flange Nut
NC	Hexagon Cap Nut
NS	Square Nut
NW	Wing Nut

Ex. ST0308S (Phillips Truss Head Machine Screw
3x8, made of stainless steel)

Material	None:	Plated Steel
Length (mm)	S:	Stainless Steel
Nominal Diameter (mm)	B:	Brass
Form of Head	P:	Plastic
Description		

(Note) Second character is numerical except toe list.

Ex. S1, S2, B3 etc.

And abbreviations and names are shown under the illustration.

MATERIAL ABBREVIATIONS

ALUMINUM

AL = Aluminum

COPPER

CU = Copper

PLASTIC

ABS = Acrylonitrile-butadiene-styrene
 AC = Polyacetal
 EVA = Ethylene vinyl acetate
 PA = Polyamide = Nylon
 PC = Polycarbonate
 PE = Polyethylene
 PES = Polyester
 PETP = Polyethylene terephthalate = Tetlon
 PP = Polypropylene
 PS = Polystyrene
 PTFE = Polytetrafluoroethylene = Teflon
 PUR = Polyurethane
 PVC = Polyvinyl chloride

RUBBER

VN = Vinyl Nitrile
 EPDM = EP rubber
 NBR = Nitrile butadiene rubber
 NR = Natural rubber
 NP = Neoprene
 SI.R = Silicone rubber
 SY.R = Synthetic rubber
 EPH = Epichlorohydrin

STEEL

GS = Galvanized steel
 SS = Stainless steel
 PS = Plated steel
 PAS = Primed steel

AUXILIARY CODE

Ex.1

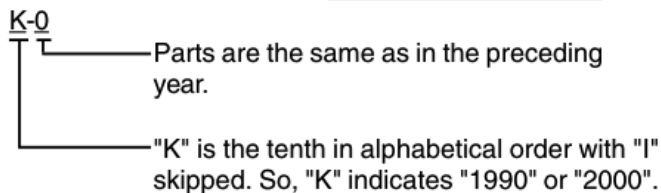

(Note) - = Part deleted.

x = Part deleted and replaced by "o" part.

o = New part for "x" in the same auxiliary code.

Ex.2

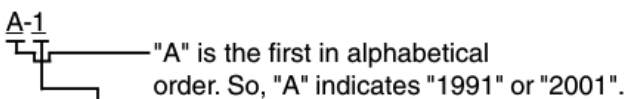

Ex.3

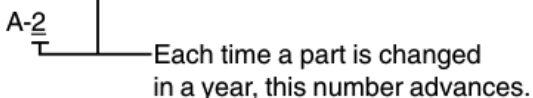

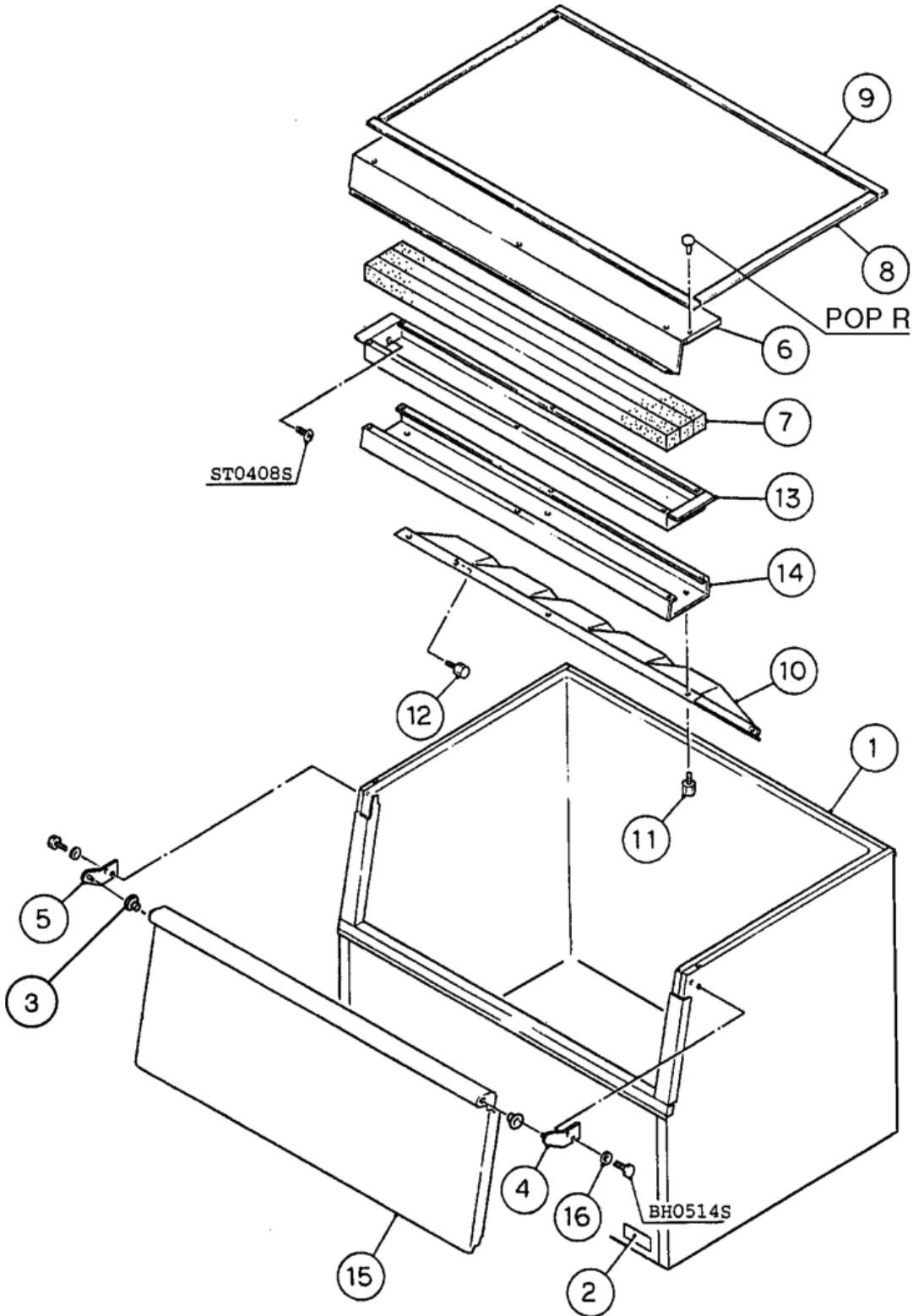

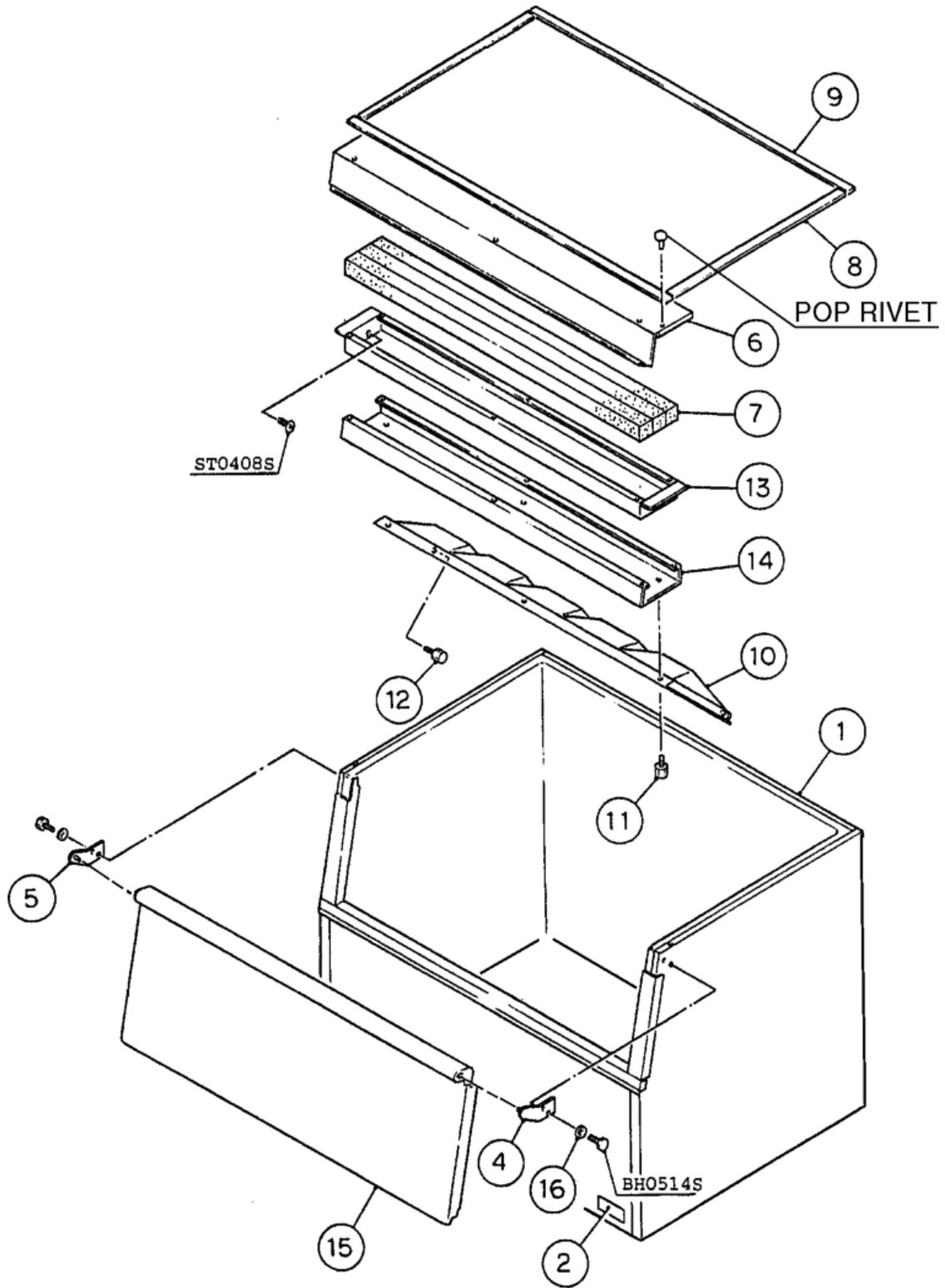

MODEL: B-250PD TITLE: A. BIN ASSEMBLY

INDEX NO.	DESCRIPTION	MATERIAL OR MODEL NUMBER	PART NUMBER	REQUIRED NUMBER																
				G-0 H-0	J-0	K-0														
1	BIN BODY	-	2A0803G01	1	1	1														
2	NAMEPLATE	PES FILM	4A0158-12	1	1	1														
3	COLLAR	POM	431496-02	2	-															
4	HINGE-BODY(R)	SS	3A0105G01	1	1	1														
5	HINGE-BODY(L)	SS	3A0106G01	1	1	1														
6	TOP COVER (5)	SS	3A0157-01	1	1	1														
7	INSULATION (C2)	PS FORM	437687-02	3	3	3														
8	GASKET	PVC, L=630	4A0808L01	2	2	2														
9	GASKET	PVC, L=757	4A0808L01	2	2	2														
10	BAFFLE (5)	PS	104322-01	1	1	1														
11	THUMBSCREW	ABS, SS	415949G01	2	2	2														
12	THUMBSCREW	ABS, SS	434168G01	2	2	2														
13	FRONT FRAME	SS	3A0420-01	1	1	1														
14	FRONT FRAME COVER (5)	ABS	324625-01	1	1	1														
15	DOOR (5)	PE	1A0034-01	1	-															
	BIN DOOR	-	3A0540G05		1	1														
16	WASHER	SS	4A0198-01	4	4	4														

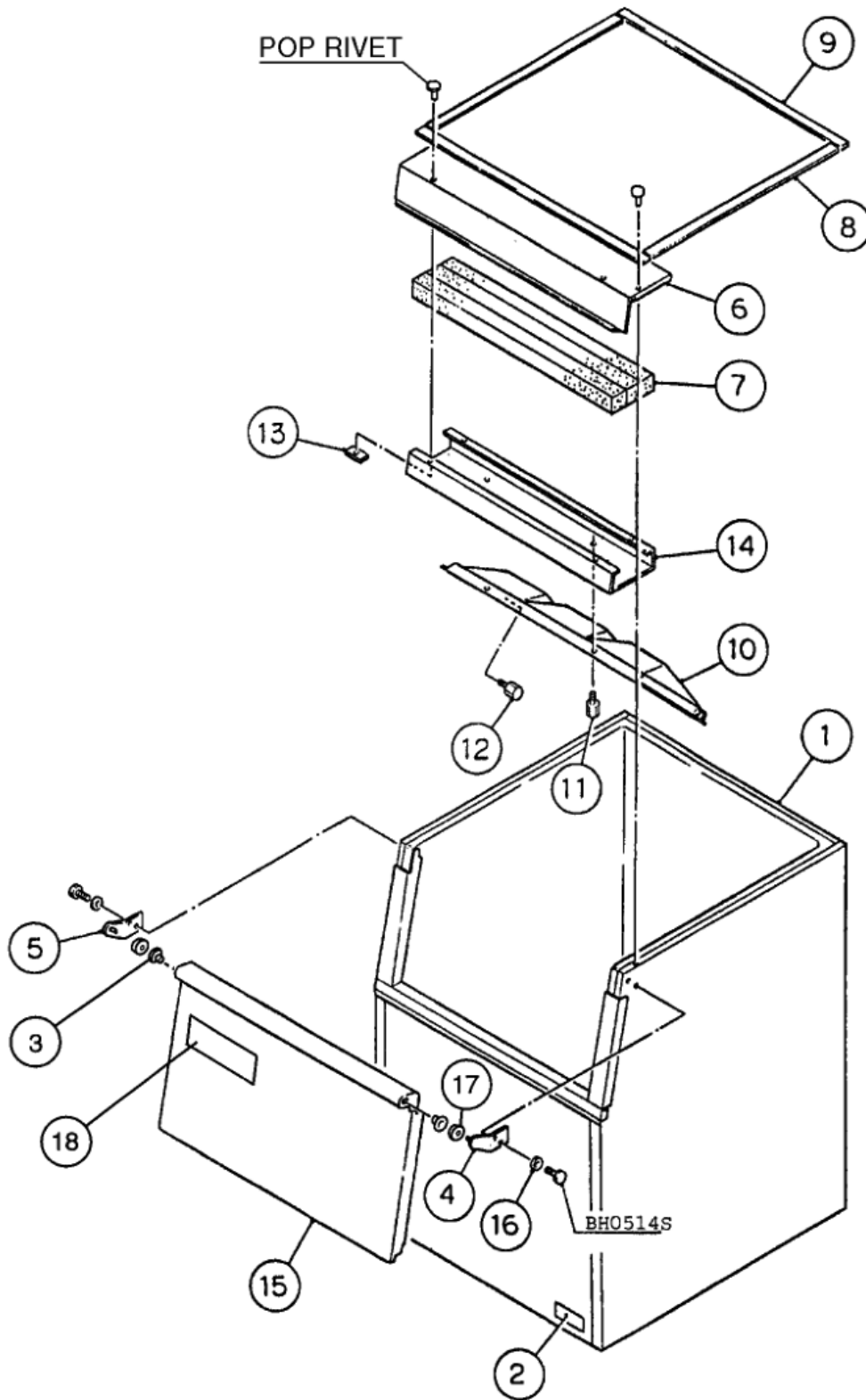

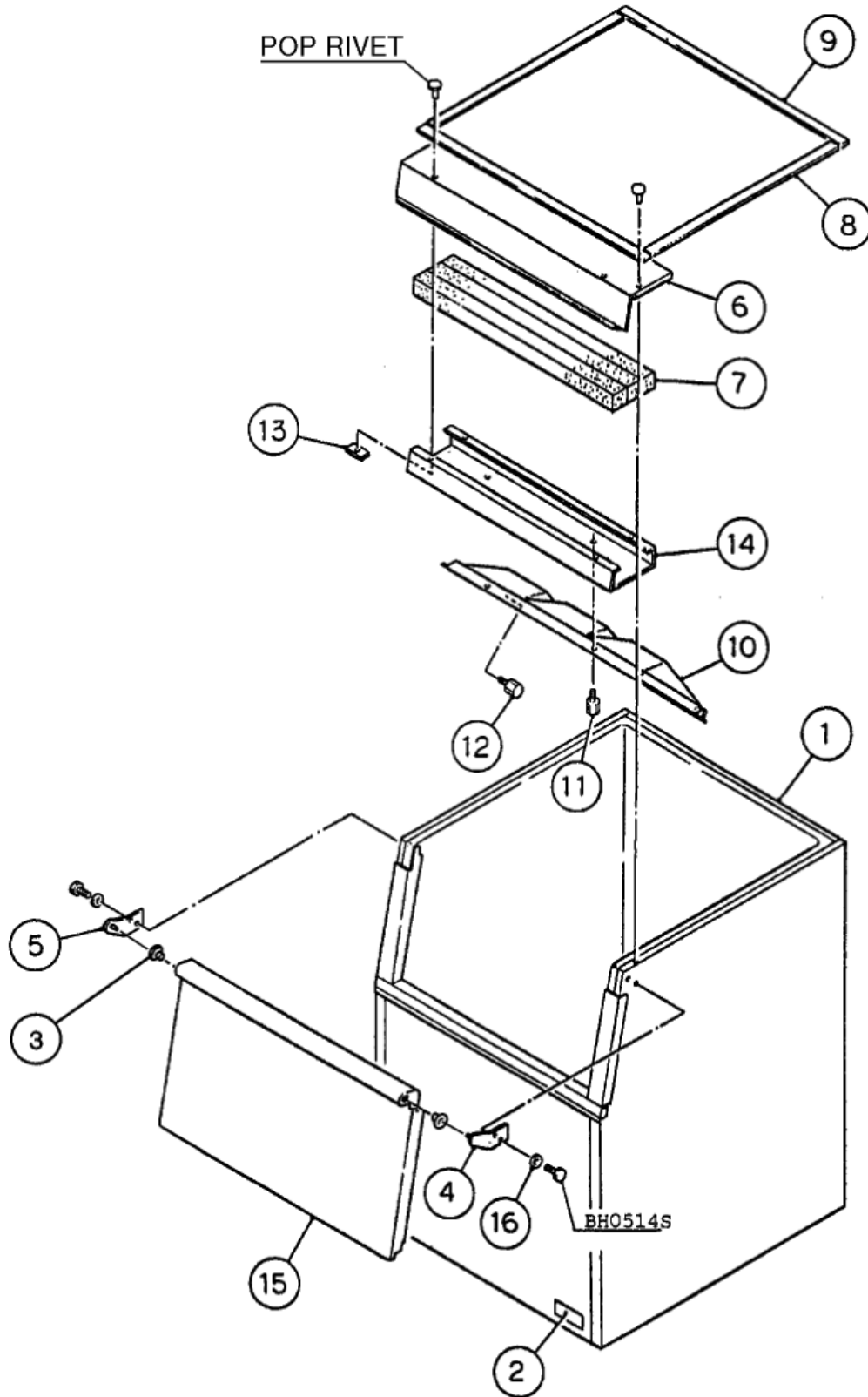

A. BIN ASSEMBLY

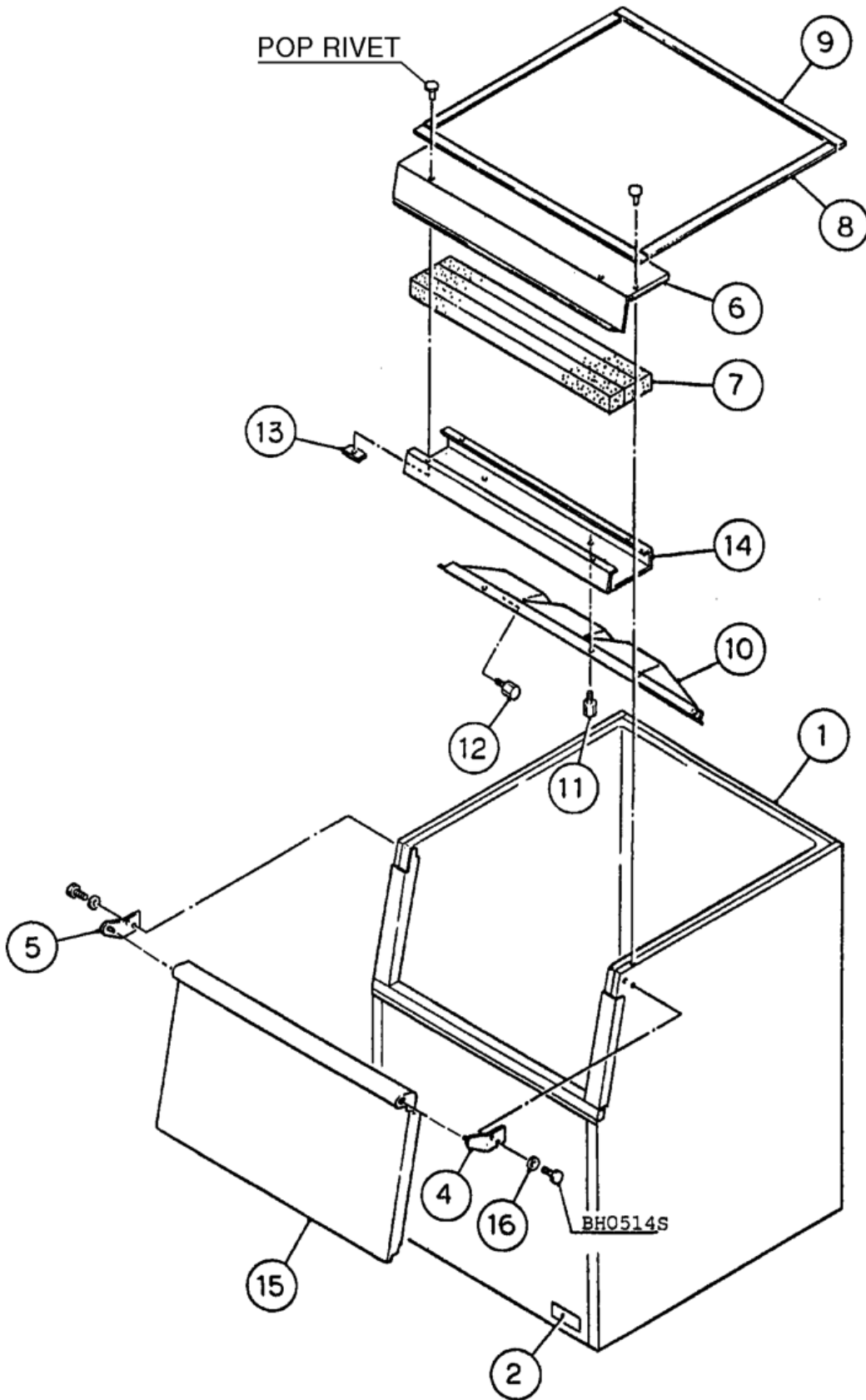

MODEL: B-300PD TITLE: A. BIN ASSEMBLY

INDEX NO.	DESCRIPTION	MATERIAL OR MODEL NUMBER	PART NUMBER	REQUIRED NUMBER									
				C-1 D-0 E-0	E-1	F-0	G-0 H-0	J-0	K-0				
1	BIN BODY	-	1A0044G01	x1									
		-	2A0484G01	o1	-								
		-	2A0512G01		1	1	1	1	1				
2	NAMEPLATE	PES FILM	4A0158-01	1	1	1	1	1	1				
3	COLLAR	POM	431496-01	2	2	x2							
		POM	431496-02			o2	2	-					
4	HINGE-BODY(R)	SS	3A0105G01	1	1	1	1	1	1				
5	HINGE-BODY(L)	SS	3A0106G01	1	1	1	1	1	1				
6	TOP COVER (3)	SS	3A0156-01	1	1	1	1	1	1				
7	INSULATION (C3)	PS FORM	437687-01	3	3	3	3	3	3				
8	SEAL (C)	PVC	434059-01	2	x2								
	GASKET	PVC, L=630	4A0808L01		o2	2	2	2	2				
9	SEAL (B3)	PVC	434058-01	2	x2								
	GASKET	PVC, L=554	4A0808L01		o2	2	2	2	2				
10	BAFFLE (3)	PS	104391-01	1	1	1	1	1	1				
11	THUMBSCREW	ABS, SS	415949G01	2	2	2	2	2	2				
12	THUMBSCREW	ABS, SS	434168G01	2	2	2	2	2	2				
13	PLATE	SS	4A0199-01	2	2	2	-						
	WASHER	SS	4A0928-01				2	2	2				
14	FRONT FRAME COVER (3)	ABS	324617-01	1	1	1	1	1	1				
15	DOOR (3)	PE	1A0034-01	1	1	1	1	-					
	BIN DOOR	-	3A0540G04					1	1				
16	WASHER	SS	4A0198-01	4	4	4	4	4	4				
17	SPACER	PA	4A0074-01	2	2	-							
18	BIN CAUTION LABEL	PAPER	4A0740-01		1	-							

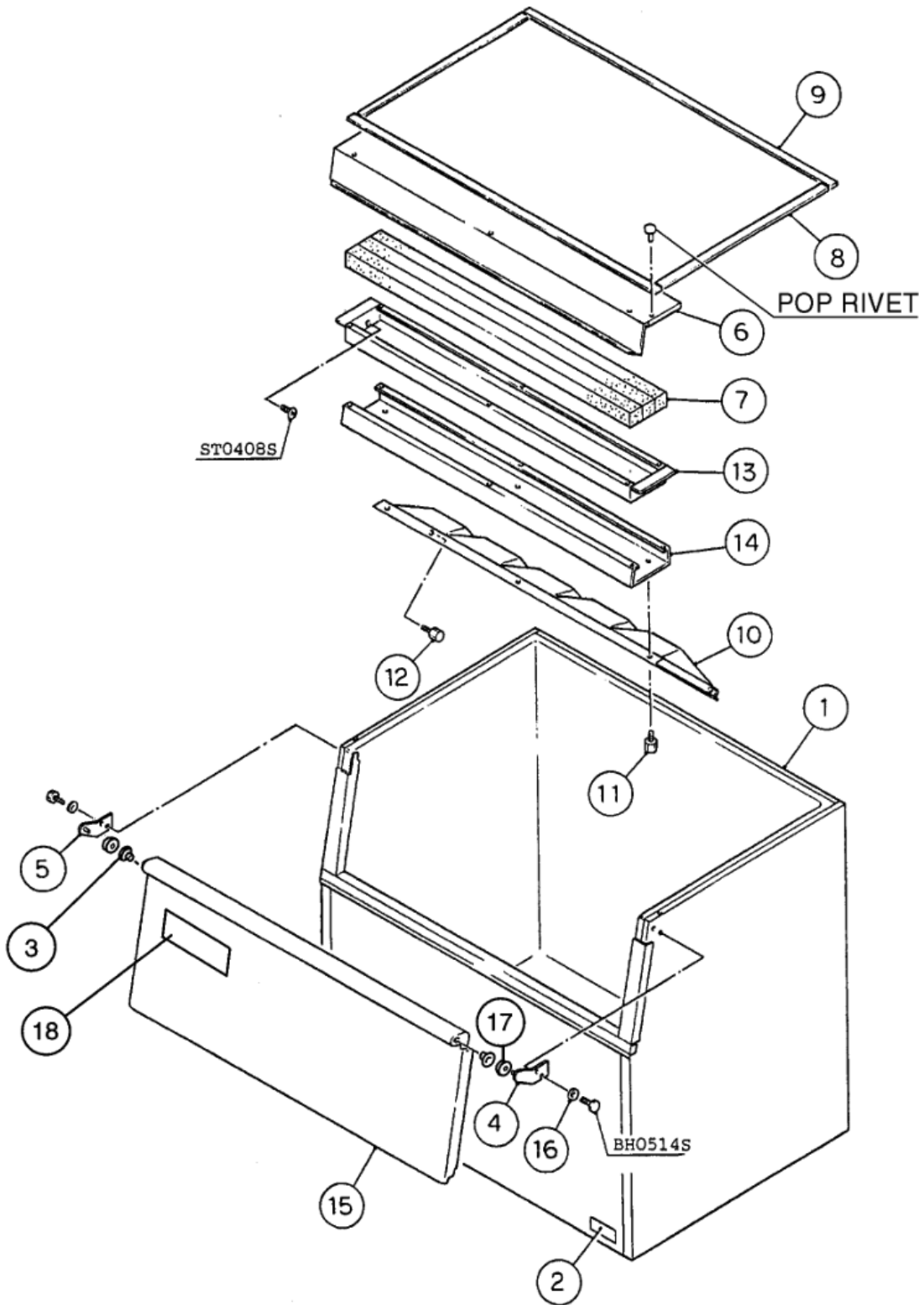

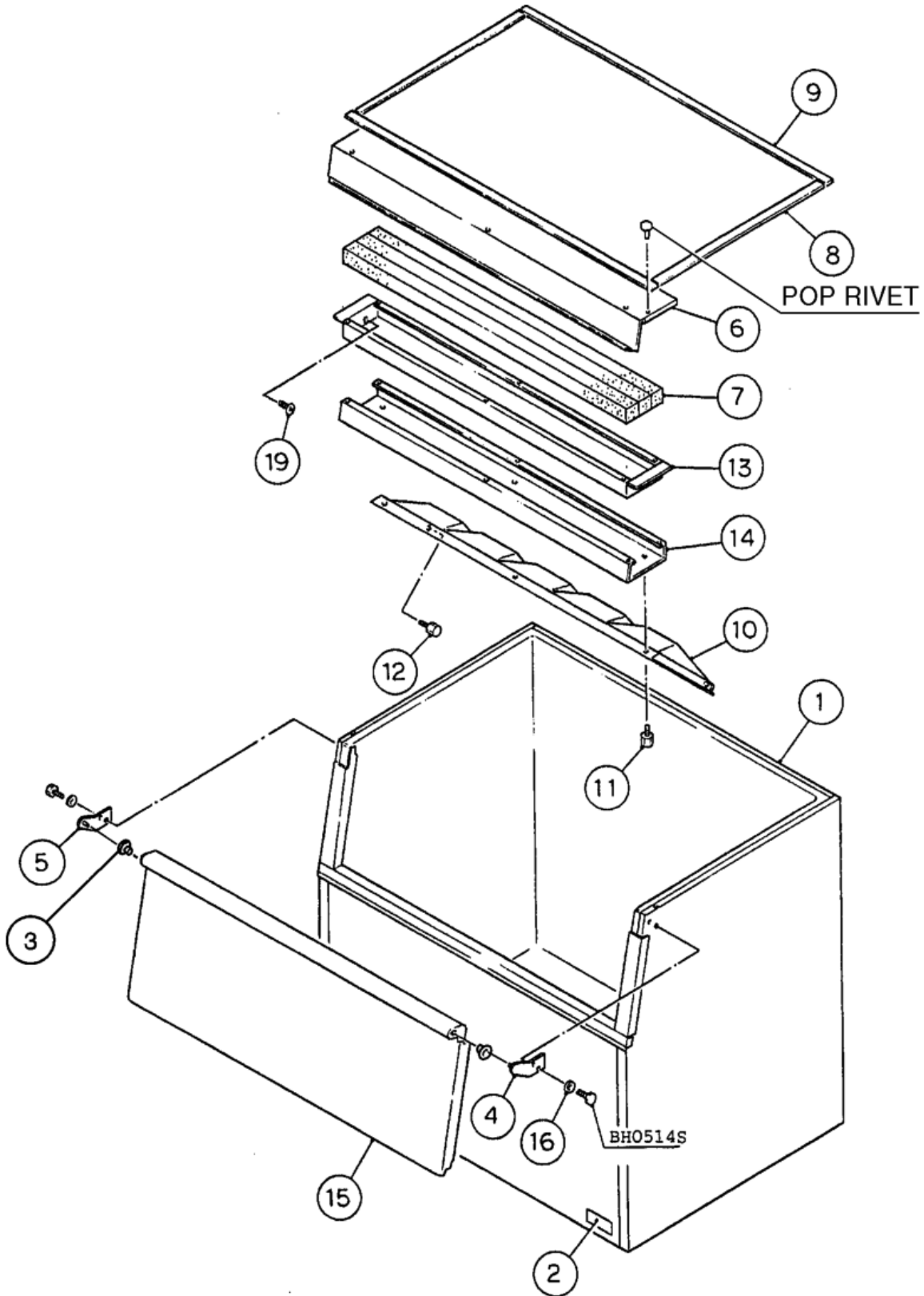

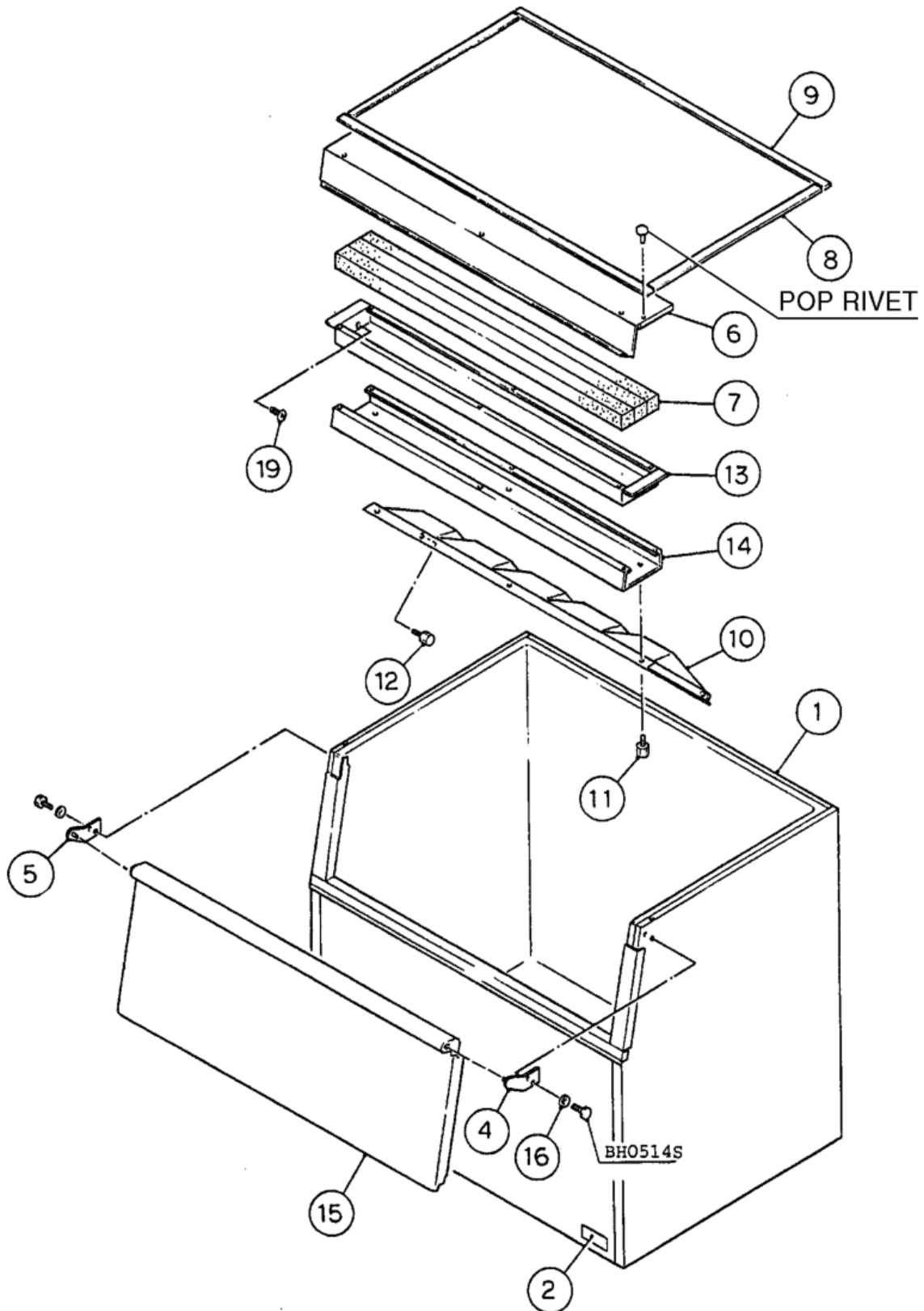

MODEL: B-500PD TITLE: A. BIN ASSEMBLY

INDEX NO.	DESCRIPTION	MATERIAL OR MODEL NUMBER	PART NUMBER	REQUIRED NUMBER									
				C-1 D-0 E-0	E-1	F-0	G-0 H-0	J-0	K-0				
1	BIN BODY	-	1A0044G02	x1									
		-	2A0484G02	o1	-								
		-	2A0512G02		1	1	1	1	1	1			
2	NAMEPLATE	PES FILM	4A0158-02	1	1	1	1	1	1				
3	COLLAR	POM	431496-01	2	2	x2							
		POM	431496-02			o2	2	-					
4	HINGE-BODY(R)	SS	3A0105G01	1	1	1	1	1	1				
5	HINGE-BODY(L)	SS	3A0106G01	1	1	1	1	1	1				
6	TOP COVER (5)	SS	3A0157-01	1	1	1	1	1	1				
7	INSULATION (C2)	PS FORM	437687-02	3	3	3	3	3	3				
8	SEAL (C)	PVC	434059-01	2	x2								
	GASKET	PVC, L=630	4A0808L01		o2	2	2	2	2				
9	SEAL (B5)	PVC	434058-02	2	x2								
	GASKET	PVC, L=757	4A0808L01		o2	2	2	2	2				
10	BAFFLE (5)	PS	104322-01	1	1	1	1	1	1				
11	THUMBSCREW	ABS, SS	415949G01	2	2	2	2	2	2				
12	THUMBSCREW	ABS, SS	434168G01	2	2	2	2	2	2				
13	FRONT FRAME (5)	SS	3A0159-01	1	-								
		SS	3A0420-01		1	1	1	1	1				
14	FRONT FRAME COVER (5)	ABS	324625-01	1	1	1	1	1	1				
15	DOOR (5)	PE	1A0034-02	1	1	1	1	-					
	BIN DOOR	-	3A0540G05					1	1				
16	WASHER	SS	4A0198-01	4	4	4	4	4	4				
17	SPACER	PA	4A0074-01	2	2	-							
18	BIN CAUTION LABEL	PAPER	4A0740-01		1	-							
19	TAPPING SCREW	-	4A0920-01			2	2	2	2				

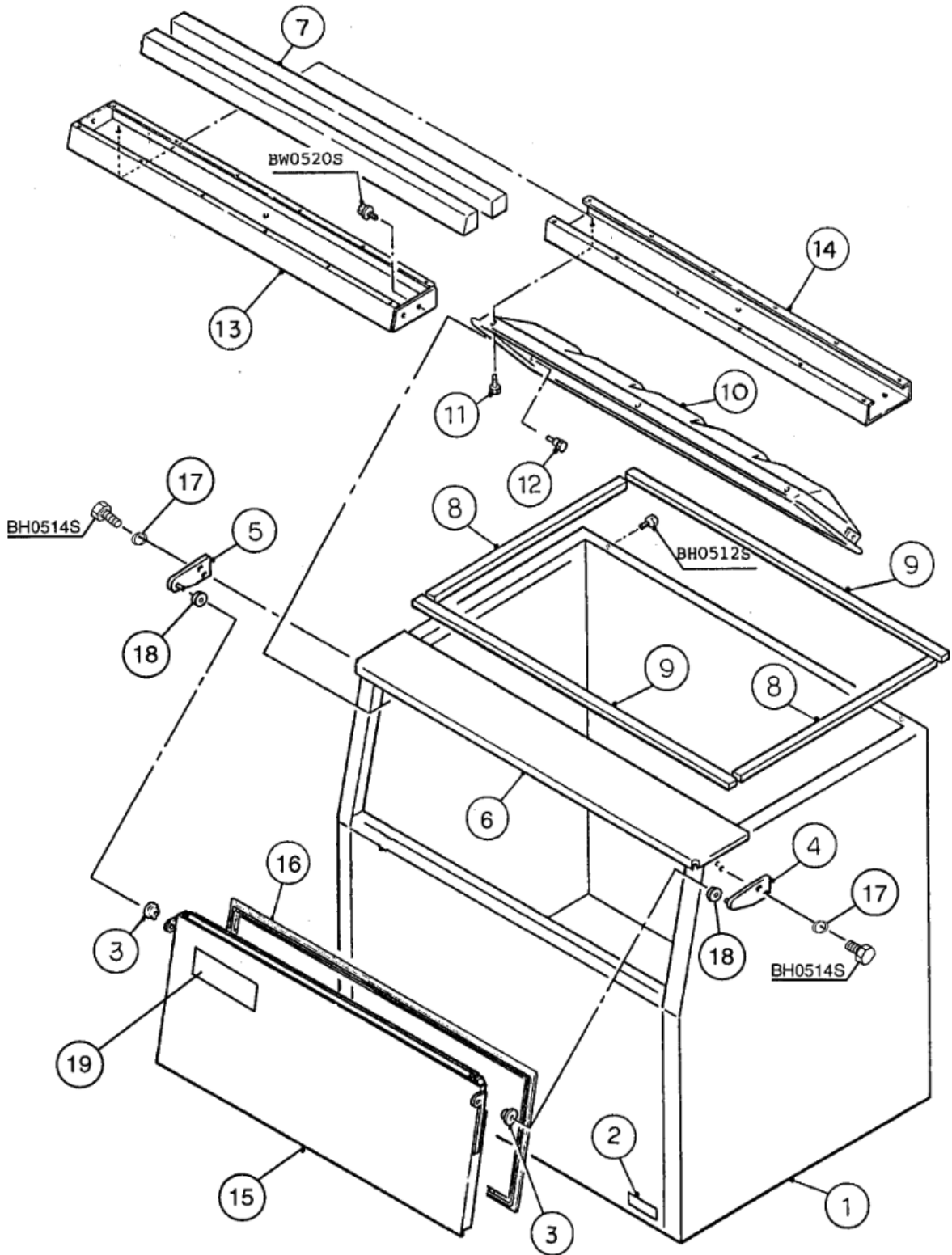

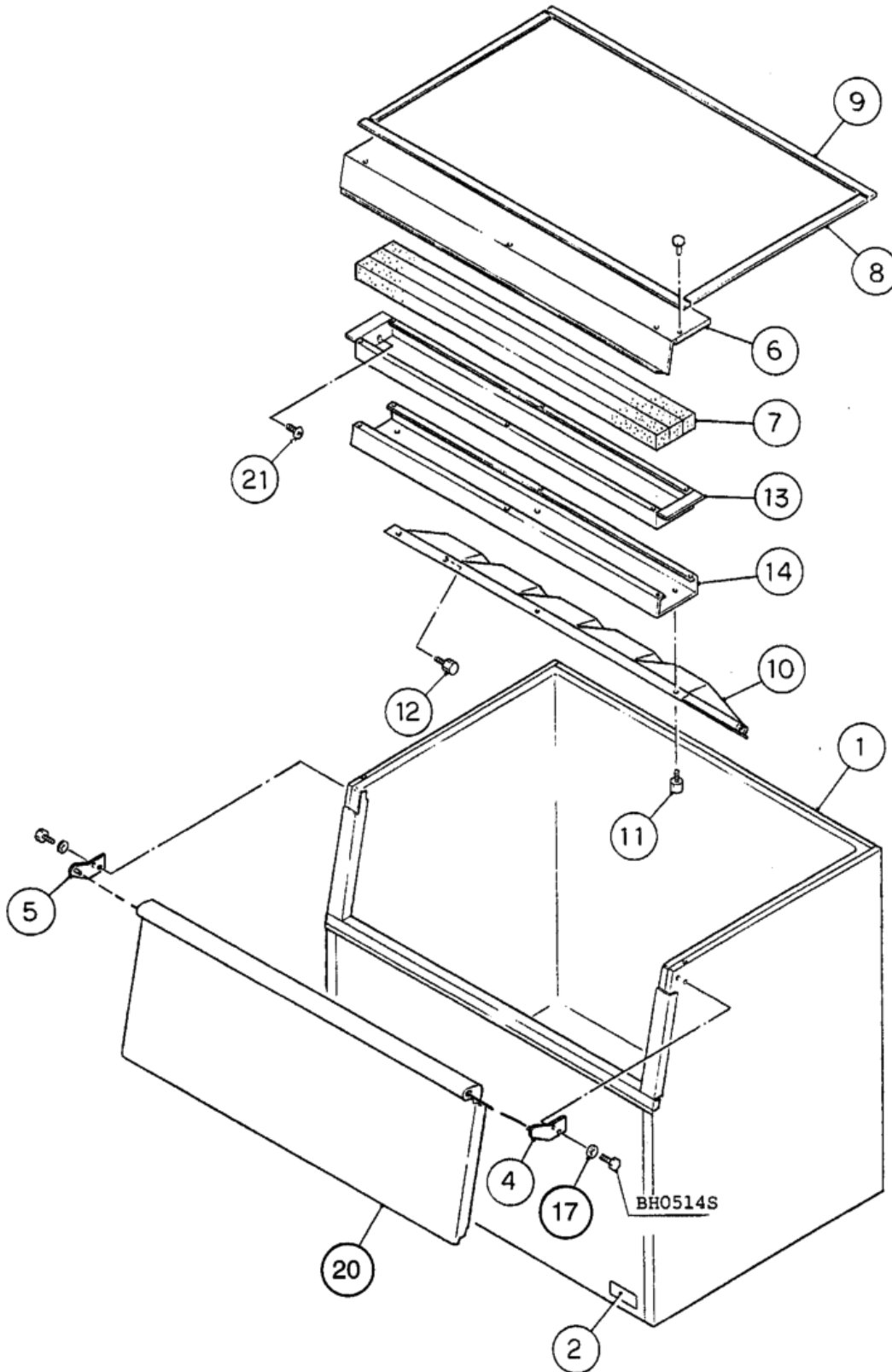

MODEL: B-700PD TITLE: A. BIN ASSEMBLY

INDEX NO.	DESCRIPTION	MATERIAL OR MODEL NUMBER	PART NUMBER	REQUIRED NUMBER									
				D-1 E-0	E-1 F-0	F-1	G-0 H-0	J-0 K-0					
1	BIN BODY	-	1A0044G11	x1									
		-	2A0484G03	o1	-								
		-	2A0512G03		1	-							
		-	2A0512G12				1	1	1				
2	NAMEPLATE	PES FILM	4A0158-03	1	1	1	1	1					
3	COLLAR-PC	POM	431496-02	2	2	-							
4	HINGE(R)	SS	437638G01	1	1	-							
	HINGE-BODY(R)	SS	3A0105G01			1	1	1					
5	HINGE (L)	SS	437640G01	1	1	-							
	HINGE-BODY(L)	SS	3A0106G01			1	1	1					
6	TOP COVER (7)	SS	214345-01	1	1	-							
		SS	3A0158-01			1	1	1					
7	INSULATION (C7)	PS FORM	437687-03	3	3	3	3	3					
8	SEAL (C)	PVC	434059-01	2	x2								
	GASKET	PVC, L=630	4A0808L01		o2	2	2	2					
9	SEAL (B3)	PVC	434058-03	2	x2								
	GASKET	PVC, L=1112.5	4A0808L01		o2	2	2	2					
10	BAFFLE (7)	PS	104323-01	1	1	1	1	1					
11	THUMBSCREW	ABS,SS	415949G01	3	3	3	3	3					
12	THUMBSCREW	ABS,SS	434168G01	2	2	2	2	2					
13	FRONT FRAME (7)	SS	3A0446-01	1	1	1	1	1					
14	FRONT FRAME COVER (7)	ABS	3A0155-01	1	1	1	1	1					
15	DOOR ASSEMBLY	(214875A03)	214657G03	1	1	-							
16	GASKET(7)		3A0052-03	1	1	-							
17	WASHER	SS	4A0198-01	4	4	4	4	4					
18	SPACER	PA	4A0074-01	2	2	-							
19	BIN CAUTION LABEL	PAPER	4A0740-01		1	-							
20	BIN DOOR	PE	3A0540G01			1	1	1					
21	TAPPING SCREW	-	4A0920-01			2	2	2					

MODEL: **B-800PD** TITLE: **A. BIN ASSEMBLY**

INDEX NO.	DESCRIPTION	MATERIAL OR MODEL NUMBER	PART NUMBER	REQUIRED NUMBER									
				D-1 E-0	E-1 F-0	F-1	G-0 H-0	J-0 K-0					
1	BIN BODY	-	1A0044G12	x1									
			2A0484G04	o1	-								
			2A0512G04		1	-							
			2A0512G13				1	1	1				
2	NAMEPLATE	PES FILM	4A0158-04	1	1	1	1	1					
3	COLLAR-PC	POM	431496-02	2	2	-							
4	HINGE (R)	SS	437638G01	1	1	-							
	HINGE-BODY (R)	SS	3A0105G01			1	1	1					
5	HINGE (L)	SS	437640G01	1	1	-							
	HINGE-BODY (L)	SS	3A0106G01			1	1	1					
6	TOP COVER (8)	SS	215331-01	1	1	-							
		SS	2A0106-01			1	1	1					
7	INSULATION (C8)	PS FORM	437687-05	3	3	3	3	3					
8	SEAL (C)	PVC	434059-01	2	x2								
	GASKET	PVC, L=630	4A0808L01		o2	2	2	2					
9	SEAL	PVC	434058-04	2	x2								
	GASKET	PVC, L=1316	4A0808L01		o2	2	2	2					
10	BAFFLE (8)	PS	105012-01	1	1	1	1	1					
11	THUMBSCREW	ABS,SS	415949G01	4	4	4	4	4					
12	THUMBSCREW	ABS,SS	434168G01	2	2	2	2	2					
13	FRONT FRAME (8)	SS	3A0447-01	1	1	1	1	1					
14	FRONT FRAME COVER (8)	ABS	325510-01	1	1	1	1	1					
15	DOOR ASSEMBLY	(214875A05)	214657G05	1	1	-							
16	GASKET (8)		3A0052-05	1	1	-							
17	WASHER	SS	4A0198-01	4	4	4	4	4					
18	SPACER	PA	4A0074-01	2	2	2	2	2					
19	BIN CAUTION LABEL	PAPER	4A0740-01		1	-							
20	BIN DOOR	PE	3A0540G02			1	1	1					
21	TAPPING SCREW	-	4A0920-01			2	2	2					

MODEL: B-900PD TITLE: A. BIN ASSEMBLY

INDEX NO.	DESCRIPTION	MATERIAL OR MODEL NUMBER	PART NUMBER	REQUIRED NUMBER									
				D-1 E-0	E-1 F-0	F-1	G-0 H-0	J-0 K-0					
1	BIN BODY	-	1A0044G13	x1									
			2A0484G05	o1	-								
			2A0512G05		1	-							
			2A0512G14				1	1	1				
2	NAMEPLATE	PES FILM	4A0158-05	1	1	1	1	1					
3	COLLAR-PC	POM	431496-02	2	2	-							
4	HINGE (R)	SS	437638G01	1	1	-							
	HINGE-BODY (R)	SS	3A0105G01			1	1	1					
5	HINGE (L)	SS	437640G01	1	1	-							
	HINGE-BODY (L)	SS	3A0106G01			1	1	1					
6	TOP COVER (9)	SS	214346-01	1	1	-							
		SS	2A0107-01			1	1	1					
7	INSULATION (C9)	PS FORM	437687-04	3	3	3	3	3					
8	SEAL (C)	PVC	434059-01	2	x2								
	GASKET	PVC, L=630	4A0808L01		o2	2	2	2					
9	SEAL (B9)	PVC	434058-04	2	x2								
	GASKET	PVC, L=1316	4A0808L01		o2	2	2	2					
10	BAFFLE (9)	PS	104324-02	1	1	1	1	1					
11	THUMBSCREW	ABS,SS	415949G01	4	4	4	4	4					
12	THUMBSCREW	ABS,SS	434168G01	2	2	2	2	2					
13	FRONT FRAME (9)	SS	3A0161-02	1	1	-							
		SS	3A0447-02			1	1	1					
14	FRONT FRAME COVER (9)	ABS	324619-01	1	1	1	1	1					
15	DOOR ASSEMBLY	(214875A04)	214657G04	1	1	-							
16	GASKET (9)		3A0052-04	1	1	-							
17	WASHER	SS	4A0198-01	4	4	4	4	4					
18	SPACER	PA	4A0074-01	2	2	2	2	2					
19	BIN CAUTION LABEL	PAPER	4A0740-01		1	-							
20	BIN DOOR	PE	3A0540G03			1	1	1					
21	TAPPING SCREW	-	4A0920-01			2	2	2					

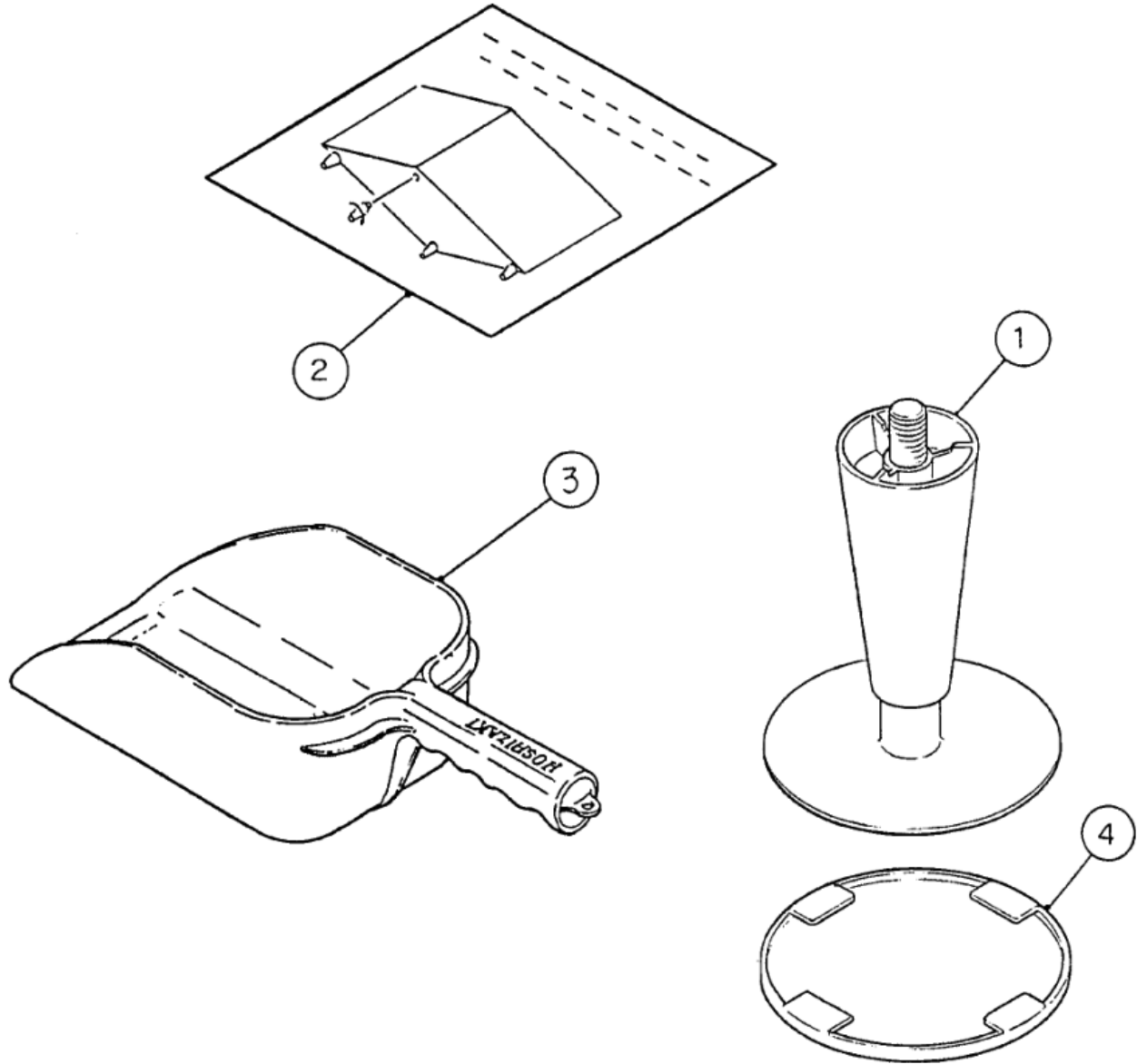

HA
B-250, 500, 700, 800, 900PD

B. ACCESSORIES

C-1, D-0, D-1, E-0, E-1, F-0,
F-1, G-0, H-0, J-0, K-0

