



HOSHIZAKI

Parts List

Modular Flaker

Models

F-1002MAJ(-C)(-SC)

F-1002MWJ(-C)

F-1002MRJ(Z)(-C)(-SC)

F-1002MLJ(-C)



hoshizakiamerica.com

Number: 71370
Issued: 6-23-2016
Revised: 10-15-2024

CONTENTS

Note About Ordering Parts	5
A. Main Assembly & Refrigeration Circuit	6
F-1002MAJ(-C)(-SC)	6
F-1002MWJ(-C)	9
F-1002MRJ(Z)(-C)(-SC)	12
F-1002MLJ(-C)	15
B. Icemaking Unit	18
C. Water Circuit	20
D. Control Box Assembly	22
E. Accessories & Labels	24

Auxiliary Codes

F-1002MAJ

F-0 July 2016
G-0 January 2017
G-1 June 2017
H-0 January 2018
H-1 September 2018
J-0 January 2019
J-1 April 2019
J-2 July 2019
J-3 August 2019
K-0 January 2020
K-1 December 2020
L-0 January 2021
L-1 June 2021
L-2 November 2021
M-0 February 2022
M-1 May 2022
N-0 January 2023
N-2 August 2023
N-3 October 2023
P-0 January 2024

F-1002MAJ-C

F-0 July 2016
G-0 January 2017
G-1 June 2017
H-0 January 2018
H-1 September 2018
J-0 January 2019
J-1 April 2019
J-2 July 2019
J-3 August 2019
K-0 January 2020
K-1 September 2020
L-0 February 2021
L-1 June 2021
L-2 November 2021
M-0 February 2022
M-1 May 2022
N-0 January 2023
N-2 August 2023
N-3 October 2023
P-0 February 2024

F-1002MAJ-SC

M-0 February 2022
M-1 July 2022
N-0 January 2023
N-2 August 2023
N-3 October 2023

F-1002MWJ

F-0 July 2016
G-0 February 2017
G-1 June 2017
H-0 January 2018
H-1 September 2018
J-0 January 2019
J-1 April 2019
J-2 July 2019
J-3 August 2019
K-0 January 2020
K-1 September 2020
L-0 January 2021
L-1 August 2021
L-2 November 2021
M-0 February 2022
M-1 May 2022
N-0 April 2023
N-2 August 2023
N-3 November 2023
P-0 April 2024

F-1002MWJ-C

F-0 July 2016
G-0 June 2017
G-1 July 2017
H-0 January 2018
H-1 September 2018
J-0 January 2019
J-1 April 2019
J-2 July 2019
J-3 October 2019
K-0 January 2020
K-1 September 2020
L-1 July 2021
L-2 November 2021
M-0 April 2022
M-1 June 2022
N-0 April 2023
N-2 August 2023
N-3 October 2023
P-0 February 2024

Auxiliary Codes (Continue)

F-1002MRJ

F-0 July 2016
G-0 January 2017
G-1 July 2017
H-0 February 2018
H-1 September 2018
J-0 January 2019
J-1 May 2019
J-2 September 2019
J-3 August 2019
K-0 January 2020
K-1 August 2021
L-0 January 2021

F-1002MRJ-C

F-0 July 2016
G-0 January 2017
G-1 June 2017
H-0 January 2018
H-1 September 2018
J-0 January 2019
J-1 April 2019
J-2 July 2019
J-3 September 2019
K-0 January 2020
K-1 September 2021
L-0 January 2021
L-1 July 2021

F-1002MRJ-SC

J-0 May 2019
J-1 July 2019
K-1 October 2020
L-1 June 2021

F-1002MRJZ

L-0 October 2021
L-1 November 2021
M-0 February 2022
M-1 May 2022
M-2 July 2022
N-0 April 2023
N-2 August 2023
N-3 October 2023
P-0 April 2024

F-1002MRJZ-C

L-0 October 2021
L-1 November 2021
M-0 March 2022
M-1 May 2022
M-2 June 2022
N-0 January 2023
N-2 August 2023
N-3 October 2023
P-0 January 2024

F-1002MRJZ-SC

M-0 April 2022
M-2 June 2022
N-0 July 2023
N-2 August 2023
N-3 November 2023
P-0 January 2024

F-1002MLJ

F-0 August 2016
G-0 February 2017
G-1 July 2017
H-0 February 2018
H-1 October 2018
J-0 January 2019
J-1 April 2019
J-2 October 2019
K-0 January 2020
L-0 February 2021
L-2 November 2021
M-0 April 2022
M-1 July 2022
N-0 April 2023
N-2 August 2023
P-0 May 2024

Auxiliary Code Breakdown

The auxiliary code is the first two characters in the serial number. The first character indicates the year. Years progress or regress in alphabetical order. The series runs from "A" through "V" and the letters "I" and "O" are skipped. The second character indicates significant part changes within a year. Base is "0" and this number advances for each change. In cases where there is a letter in parentheses, this designates the month. This is the last character in the serial number. The series runs from "(A)" through "(M)" and the letter "(I)" is skipped. This designation is only included when identifying a parts change within an auxiliary code.

Note About Ordering Parts

Most assemblies cannot be ordered as complete units; parts in the assemblies generally must be ordered separately.

A. Main Assembly & Refrigeration Circuit
F-1002MAJ(-C)(-SC)
 F-0 to P-0

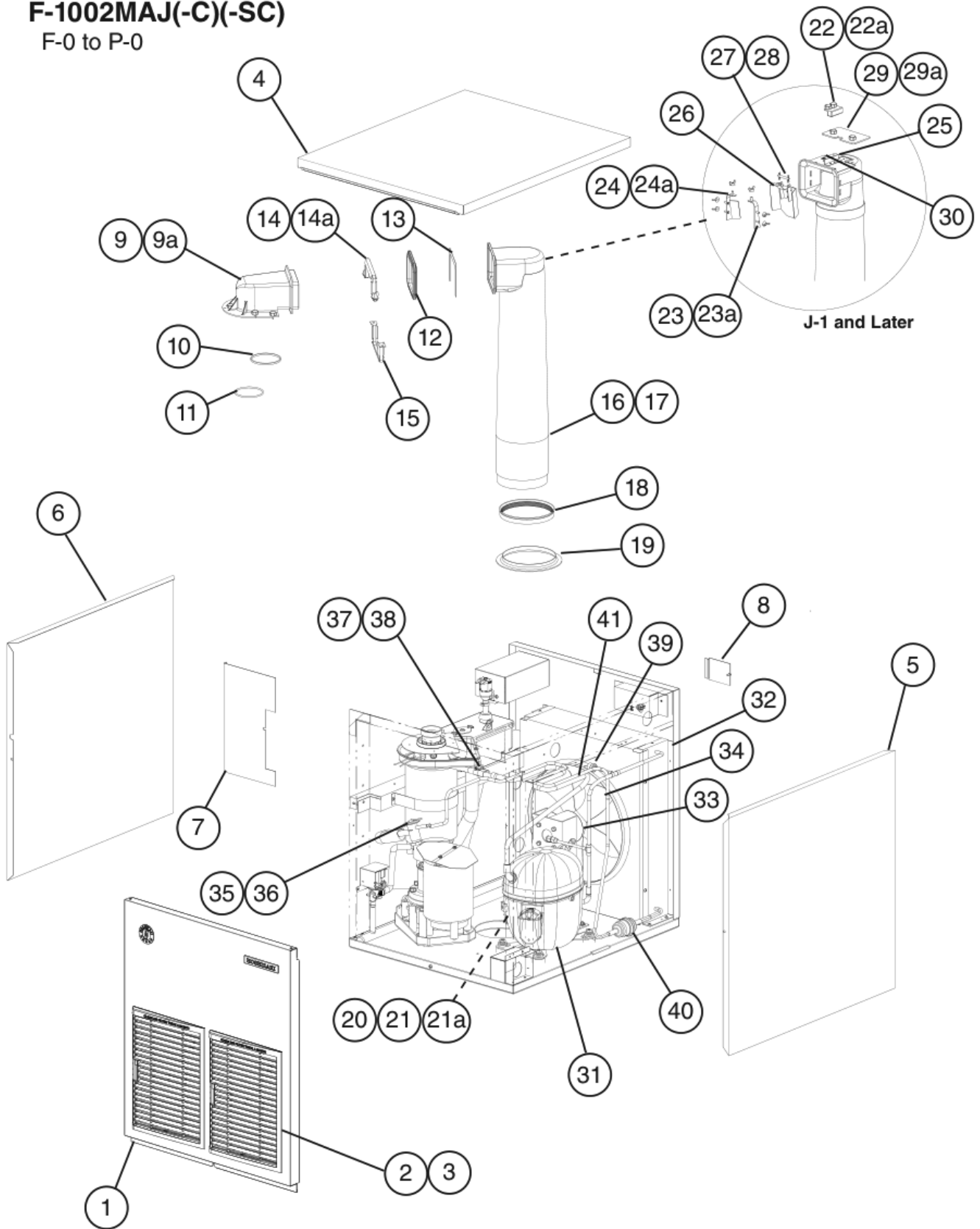

Title: A. Main Assembly & Refrigeration Circuit Model: F-1002MAJ(-C) (-SC)										
Index No.	Description	Material or Model Number	Part Number	Required Number						
				F-0 to J-0	J-1 to N-0	N-2	N-3 P-0			
Main Assembly										
1	Front Panel (includes items 2 and 3)		1A6822A01	1	1	1	1			
2	Louver		1A0548-01	2	2	2	2			
3	Air Filter		2A2063G01	2	2	2	2			
4	Top Panel		2A2064-02	1	1	1	1			
5	Right Side Panel		2A2073G01	1	1	1	1			
6	Left Side Panel		2A2072G01	1	1	1	1			
7	Control Box Cover		3A0411-01	1	1	-				
			3B1302-01			1	1			
8	Junction Box Cover		433410-01	1	1	1	1			
9	Spout		104797-01	1	1	1	1			
9a	Thumbscrew		415949G08	5	5	5	5			
10	O-Ring		4A4755-03	1	1	1	1			
11	Nylon Ring		432661-02	1	1	1	1			
12	Spout-to-Chute Packing		321037-01	1	1	1	1			
13	Spout-to-Chute Bracket		4A1712-01	1	1	1	1			
14	Upper Strap		328703-02	1	1	1	1			
14a	Wing Nut		7E12-0600	2	2	2	2			
15	Lower Strap		321038G02	1	1	1	1			
16	Chute		2A1919-01	1	1	1	1			
17	Chute Insulation		2A1920-01	1	1	1	1			
18	Chute Packing		432877-01	1	1	1	1			
19	Ring		3A1017-01	1	1	1	1			
20	Bin Control - Infrared Sensor		4A4469-01	1	1	1	-			
	Bin Control - Ultrasonic Sensor		4A6148G01				1			
21	Infrared Sensor Housing		3A3478-02	1	1	1	-			
	Ultrasonic Sensor Housing		1A6270-01				1			
21a	Thumbscrew		415949G08	1	1	1	-			
			415949G10				1			
22	Bin Control 2 Proximity Switch (mechanical bin control)		4A2033-01		1	1	1			
22a	Thumbscrew		415949G10		2	2	2			
23	Chute Baffle A		3A0400G01		1	1	1			
23a	Wing Nut		7E12-0400		3	3	3			
24	Chute Baffle B		3A0399G01		1	1	1			
24a	Wing Nut		7E12-0400		3	3	3			
25	Bin Control 2 Bracket (mechanical bin control)		3A1744G01		1	1	1			
26	Actuator		436848G01		1	1	1			
27	Shaft		436851-01		1	1	1			
28	Snap Pin		715S-0005		2	2	2			
29	Plate		4A2039-01		1	1	1			
29a	Thumbscrew		415949G10		2	2	2			
30	Truss Head Screw (ground)		7C32-0408		1	1	1			

Title: A. Main Assembly & Refrigeration Circuit Model: F-1002MAJ(-C) (-SC)												
Index No.	Description	Material or Model Number	Part Number	Required Number								
				F-0 to J-0	J-1 to N-0	N-2	N-3 P-0					
Refrigeration Circuit												
31	Compressor		4A5669-01	1	1	1	1					
32	Condenser		211663-02	1	1	1	1					
33	Fan Motor		4A3158-01	1	1	1	1					
34	Fan Blade		4A0197-01	1	1	1	1					
35	Thermostatic Expansion Valve		4A3493-01	1	1	1	1					
36	Thermostatic Expansion Valve Cover		4A1168-01	1	1	1	1					
37	Thermostatic Expansion Valve Bulb Holder		3A0112-01	1	1	1	1					
38	Clamp		443461-01	1	1	1	1					
39	High-Pressure Switch		463180-04	1	1	1	1					
40	Drier		4A2666-01	1	1	1	1					
41	Heat Exchanger		3A7886G01	1	1	1	1					

A. Main Assembly & Refrigeration Circuit
F-1002MWJ(-C)
 F-0 to P-0

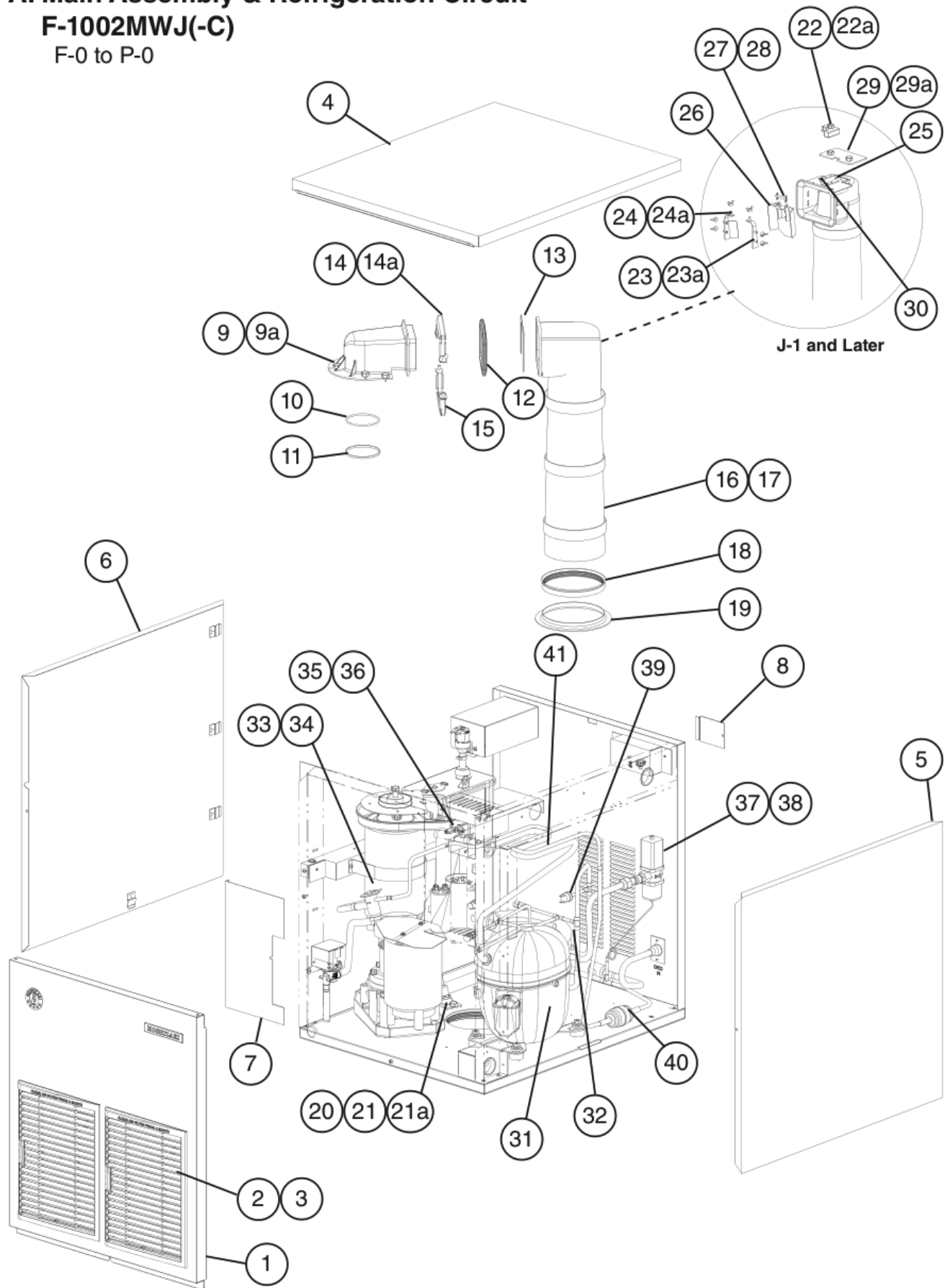

Title: A. Main Assembly & Refrigeration Circuit Model: F-1002MWJ(-C)

Index No.	Description	Material or Model Number	Part Number	Required Number							
				F-0 to J-0	J-1 to N-0	N-2	N-3 P-0				
Main Assembly											
1	Front Panel (includes items 2 and 3)		1A6822A01	1	1	1	1				
2	Louver		1A0548-01	1	1	1	1				
3	Air Filter		2A2063G01	1	1	1	1				
4	Top Panel		2A2064-02	1	1	1	1				
5	Right Side Panel		2A2073G01	1	1	1	1				
6	Left Side Panel		2A2072G01	1	1	1	1				
7	Control Box Cover		3A0411-01	1	1	1	-				
			3B1302-01				1				
8	Junction Box Cover		433410-01	1	1	1	1				
9	Spout		104797-01	1	1	1	1				
9a	Thumbscrew		415949G08	5	5	5	5				
10	O-Ring		4A4755-03	1	1	1	1				
11	Nylon Ring		432661-02	1	1	1	1				
12	Spout-to-Chute Packing		321037-01	1	1	1	1				
13	Spout-to-Chute Bracket		4A1712-01	1	1	1	1				
14	Upper Strap		328703-02	1	1	1	1				
14a	Wing Nut		7E12-0600	2	2	2	2				
15	Lower Strap		321038G02	1	1	1	1				
16	Chute		2A1919-01	1	1	1	1				
17	Chute Insulation		2A1920-01	1	1	1	1				
18	Chute Packing		432877-01	1	1	1	1				
19	Ring		3A1017-01	1	1	1	1				
20	Bin Control 1 Infrared Sensor		4A4469-01	1	1	1	-				
	Bin Control 1 Ultrasonic Sensor		4A6148G01				1				
21	Infrared Sensor Housing		3A3478-02	1	1	1	-				
	Ultrasonic Sensor Housing		1A6270-01				1				
21a	Thumbscrew		415949G08	1	1	1	-				
			415949G10				1				
22	Bin Control 2 Proximity Switch (mechanical bin Control)		4A2033-01		1	1	1				
22a	Thumbscrew		415949G10		2	2	2				
23	Chute Baffle A		3A0400G01		1	1	1				
23a	Wing Nut		7E12-0400		3	3	3				
24	Chute Baggle B		3A0399G01		1	1	1				
24a	Wing Nut		7E12-0400		3	3	3				
25	Bin Control 2 Bracket (mechanical bin control)		3A1744G01		1	1	1				
26	Actuator		436848G01		1	1	1				
27	Shaft		436851-01		1	1	1				
28	Snap Pin		715S-0005		2	2	2				
29	Plate		4A2039-01		1	1	1				
29a	Thumbscrew		415949G10		2	2	2				
30	Truss Head Screw (ground)		7C32-0408		1	1	1				

Title: A. Main Assembly & Refrigeration Circuit Model: F-1002MWJ(-C)												
Index No.	Description	Material or Model Number	Part Number	Required Number								
				F-0 to J-0	J-1 to N-0	N-2	N-3 P-0					
Refrigeration Circuit												
31	Compressor		4A5669-01	1	1	1	1					
32	Condenser		211663-02	1	1	1	1					
33	Thermostatic Expansion Valve		4A3493-01	1	1	1	1					
34	Thermostatic Expansion Valve Cover		4A1168-01	1	1	1	1					
35	Thermostatic Expansion Valve Bulb Holder		3A0112-01	1	1	1	1					
36	Clamp		443461-01	1	1	1	1					
37	Water Regulating valve		4A0911-07	1	1	1	-					
			4A5309-01				1					
38	Male Connector		4A1087-01	1	1	1	-					
39	High-Pressure Switch		463180-05	1	1	1	-					
			05A7070-04				1					
40	Drier		4A2666-01	1	1	1	1					
41	Heat Exchanger		3A7886G01	1	1	1	1					

A. Main Assembly & Refrigeration Circuit
F-1002MRJ(Z)(-C)(-SC)
 F-0 to P-0

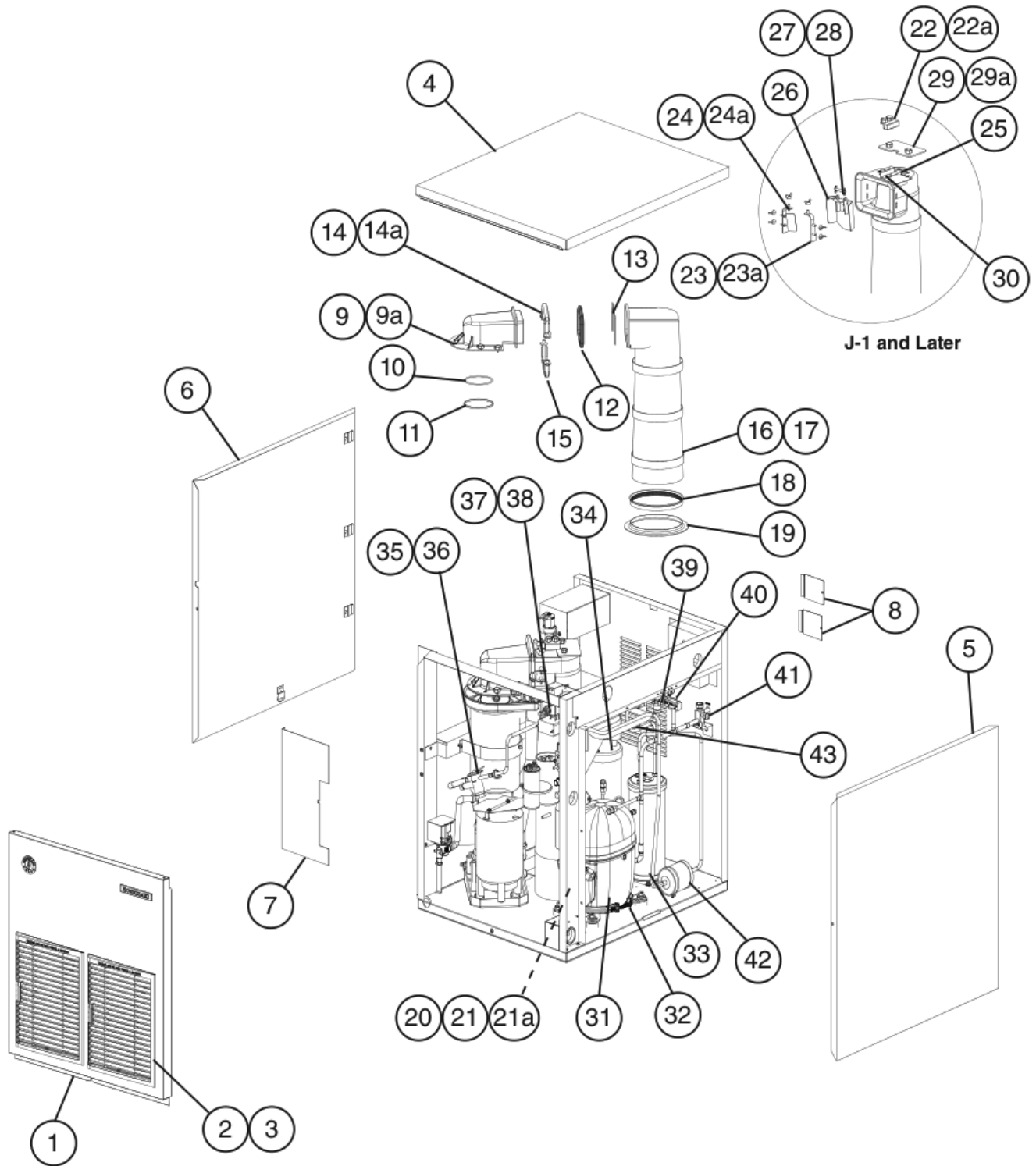

Title: A. Main Assembly & Refrigeration Circuit Model: F-1002MRJ(Z)(-C)(-SC)											
Index No.	Description	Material or Model Number	Part Number	Required Number							
				F-0 to J-0	J-1 to K-1	L-0	L-1	N-0	N-2	N-3 P-0	
Main Assembly											
1	Front Panel (includes items 2 and 3)	F-1002MRJ(-C) F-1002MRJ-SC F-1002MRJZ(-C) F-1002MRJZ-SC	1A6822A01	1	1	1	1	1	1	1	
2	Louver		1A0548-01	2	2	2	2	2	2	2	
3	Air Filter		2A2063G01	2	2	2	2	2	2	2	
4	Top Panel		2A2064-02	1	1	1	1	1	1	1	
5	Right Side Panel		2A2073G01	1	1	1	1	1	1	1	
6	Left Side Panel		2A2072G01	1	1	1	1	1	1	1	
7	Control Box Cover		3A0411-01 3B1302-01	1	1	1	1	1	-	1	1
8	Junction Box Cover		433410-01	1	1	1	1	1	1	1	
9	Spout		104797-01	1	1	1	1	1	1	1	
9a	Thumbscrew		415949G08	5	5	5	5	5	5	5	
10	O-Ring		4A4755-03	1	1	1	1	1	1	1	
11	Nylon Ring		432661-02	1	1	1	1	1	1	1	
12	Spout-to-Chute Packing		321037-01	1	1	1	1	1	1	1	
13	Spout-to-Chute Bracket		4A1712-01	1	1	1	1	1	1	1	
14	Upper Strap		328703-02	1	1	1	1	1	1	1	
14a	Wing Nut		7E12-0600	2	2	2	2	2	2	2	
15	Lower Strap		321038G02	1	1	1	1	1	1	1	
16	Chute		2A1919-01	1	1	1	1	1	1	1	
17	Chute Insulation		2A1920-01	1	1	1	1	1	1	1	
18	Chute Packing		432877-01	1	1	1	1	1	1	1	
19	Ring		3A1017-01	1	1	1	1	1	1	1	
20	Bin Control 1 Infrared Sensor		4A4469-01	1	1	1	1	1	1	-	
	Bin Control 1 Ultrasonic Sensor		4A6148G01								1
21	Infrared Sensor Housing		3A3478-02	1	1	1	1	1	1	-	
	Ultrasonic Sensor Housing		1A6270-01								1
21a	Thumbscrew		415949G08 415949G10	1	1	1	1	1	1	-	1
22	Bin Control 2 Proximity Switch (mechanical bin Control)		4A2033-01		1	1	1	1	1	1	
22a	Thumbscrew		415949G10		2	2	2	2	2	2	
23	Chute Baffle A		3A0400G01		1	1	1	1	1	1	
23a	Wing Nut		7E12-0400		3	3	3	3	3	3	
24	Chute Baggle B		3A0399G01		1	1	1	1	1	1	
24a	Wing Nut		7E12-0400		3	3	3	3	3	3	
25	Bin Control 2 Bracket (mechanical bin control)		3A1744G01		1	1	1	1	1	1	
26	Actuator		436848G01		1	1	1	1	1	1	
27	Shaft		436851-01		1	1	1	1	1	1	
28	Snap Pin		715S-0005		2	2	2	2	2	2	
29	Plate		4A2039-01		1	1	1	1	1	1	
29a	Thumbscrew		415949G10		2	2	2	2	2	2	
30	Truss Head Screw (ground)		7C32-0408		1	1	1	1	1	1	

Title: A. Main Assembly & Refrigeration Circuit Model: F-1002MRJ(Z)(-C)(-SC)											
Index No.	Description	Material or Model Number	Part Number	Required Number							
				F-0 to J-0	J-1 to K-1	L-0	L-1	N-0	N-2	N-3 P-0	
Refrigeration Circuit											
31	Compressor		4A5669-01	1	1	1	1	1	1	1	
32	Crankcase Heater		4A5091-01	1	1	1	1	1	1	1	
33	Receiver Tank		4A6212-01	1	1	1	1	1	1	1	
34	Accumulator		3A4276-01	1	1	1	1	1	1	-	
			3B1322-01								1
35	Thermostatic Expansion Valve		4A3493-01	1	1	1	1	1	1	1	
36	Thermostatic Expansion Valve Cover		4A1168-01	1	1	1	1	1	1	1	
37	Thermostatic Expansion Valve Bulb Holder		3A0112-01	1	1	1	1	1	1	1	
38	Clamp		443461-01	1	1	1	1	1	1	1	
39	Discharge Line Coupling	F-1002MRJ	434132G01	1	1	1					
		F-1002MRJ-C(-SC)		1	1	1	1				
	Discharge Line Service Valve	F-1002MRJZ(-C)(-SC)	4A3491-01			1	1	1	1	1	
40	Liquid Line Coupling	F-1002MRJ	433751G01	1	1	1					
		F-1002MRJ-C(-SC)		1	1	1	1				
	Liquid Line Service Valve	F-1002MRJZ(-C)(-SC)	4A3491-01			1	1	1	1	1	
41	High-Pressure Switch		463180-04	1	1	1	1	1	1	1	
42	Drier		4A2666-01	1	1	1	1	1	1	1	
43	Heat Exchanger		3A7886G01	1	1	1	1	1	1	1	

A. Main Assembly & Refrigeration Circuit
F-1002MLJ(-C)
 F-0 to P-0

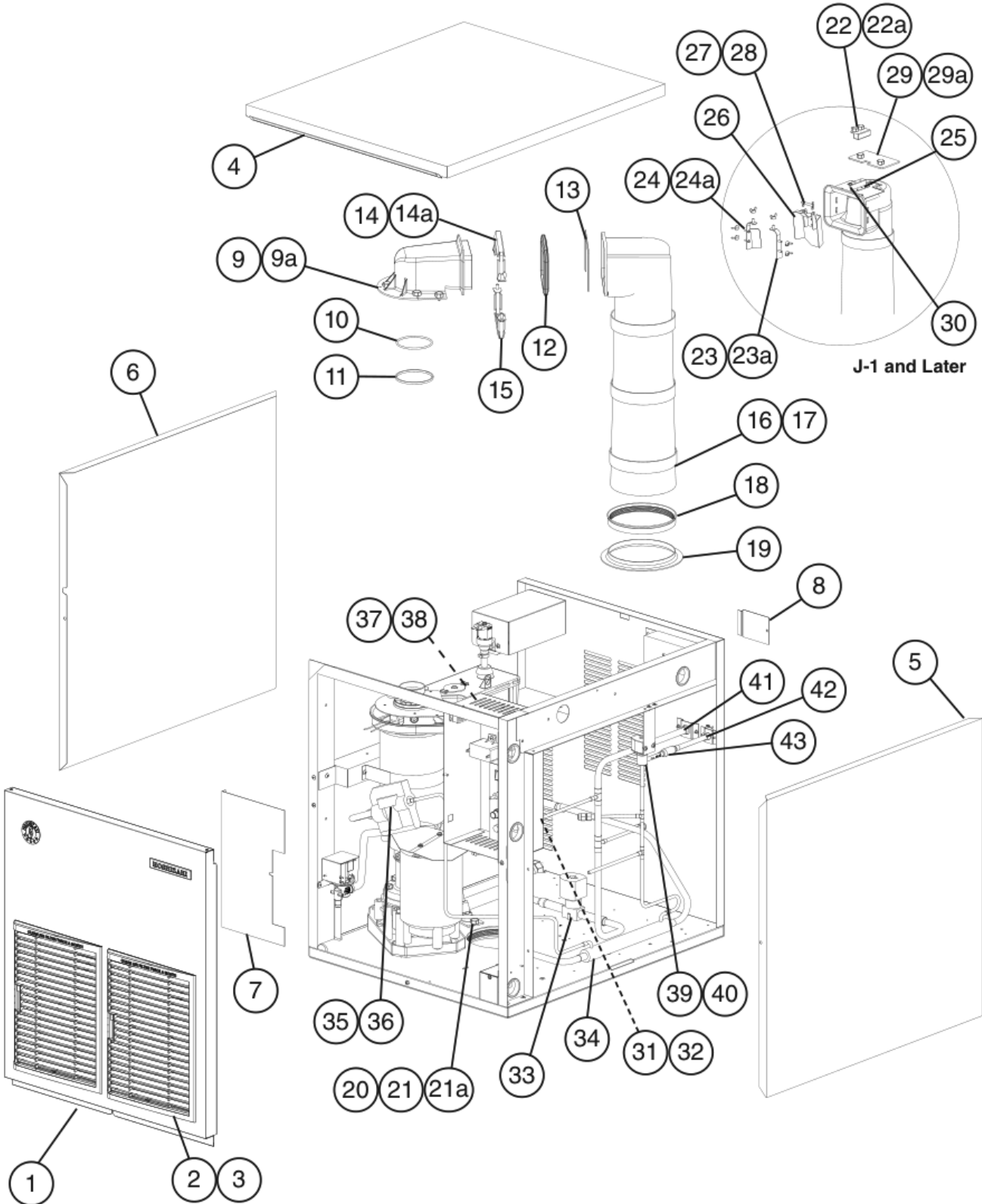

Title: A. Main Assembly & Refrigeration Circuit Model: F-1002MLJ(-C)										
Index No.	Description	Material or Model Number	Part Number	Required Number						
				F-0 to G-1	H-0 to J-0	J-1 to N-2	P-0			
Main Assembly										
1	Front Panel (Includes items 2 and 3)		1A6822A01	1	1	1	1			
2	Louver		1A0548-01	1	1	1	1			
3	Air Filter		2A2063G01	1	1	1	1			
4	Top Panel		2A2064-02	1	1	1	1			
5	Right Side Panel		2A2073G01	1	1	1	1			
6	Left Side Panel		2A2072G01	1	1	1	1			
7	Control Box Cover		3A0411-01	1	1	1	-			
			3B1302-01				1			
8	Junction Box Cover		433410-01	1	1	1	1			
9	Spout		104797-01	1	1	1	1			
9a	Thumbscrew		415949G08	5	5	5	5			
10	O-Ring		4A4755-03	1	1	1	1			
11	Nylon Ring		432661-02	1	1	1	1			
12	Spout-to-Chute Packing		321037-01	1	1	1	1			
13	Spout-to-Chute Bracket		4A1712-01	1	1	1	1			
14	Upper Strap		328703-02	1	1	1	1			
14a	Wing Nut		7E12-0600	2	2	2	2			
15	Lower Strap		328703-01	1	1	1	1			
16	Chute		2A1919-01	1	1	1	1			
17	Chute Insulation		2A1920-01	1	1	1	1			
18	Chute Packing		432877-01	1	1	1	1			
19	Ring		3A1017-01	1	1	1	1			
20	Bin Control 1 Infrared Sensor		3A3478-01	1	1	1	-			
	Bin Control 1 Ultrasonic Sensor		4A6148G01				1			
21	Infrared Sensor Housing		4A4469-01	1	1	1	-			
	Ultrasonic Sensor Housing		1A6270-01				1			
21a	Thumbscrew		415949G08	1	1	1	-			
			415949G10				1			
22	Bin Control 2 Proximity Switch (mechanical bin control)		4A2033-01			1	1			
22a	Thumbscrew		415949G10			2	2			
23	Chute Baffle A		3A0400G01			1	1			
23a	Wing Nut		7E12-0400			3	3			
24	Chute Baffle B		3A0399G01			1	1			
24a	Wing Nut		7E12-0400			3	3			
25	Bin Control 2 Bracket (mechanical bin control)		3A1744G01			1	1			
23	Actuator		436848G01			1	1			
27	Shaft		436851-01			1	1			
28	Snap Pin		715S-0005			2	2			
29	Plate		4A2039-01			1	1			
29a	Thumbscrew		415949G10			2	2			
30	Truss Head Screw		7C32-0408			1	1			

Title: A. Main Assembly & Refrigeration Circuit Model: F-1002MLJ(-C)										
Index No.	Description	Material or Model Number	Part Number	Required Number						
				F-0 to G-1	H-0 to J-0	J-1 to N-2	P-0			
Refrigeration Circuit										
31	Evaporator Pressure Regulator Valve (EPR)		4A1384-01	1	1	1	1			
32	Evaporator Pressure Regulator Valve Cover		340434-01	1	1	1	1			
33	Suction Line Valve		446873-01	1	1	1	1			
34	Heat Exchanger		4A1374-01	1	1	1	1			
35	Thermostatic Expansion Valve		4A3493-01	1	1	1	1			
36	Thermostatic Expansion Valve Cover		4A1168-01	1	1	1	1			
37	Thermostatic Expansion Valve Bulb Holder		3A0112-01	1	1	1	1			
38	Clamp		443461-01	1	1	1	1			
39	Liquid Line Valve		4A3276-01	1	1	1	1			
40	Valve Coil		4A3277-01	1	1	1	1			
41	Discharge Line Coupling		434132G01	1	1	-				
	Discharge Line Service Valve		4A4822-01			1	1			
42	Liquid Line Coupling		433751G01	1	1	-				
	Liquid Line Service Valve		4A3491-01			1	1			
43	Strainer		4A1385-01	1	1	1				

B. Icemaking Unit
F-1002M_J(Z)(-C)(-SC)
 F-0 to P-0

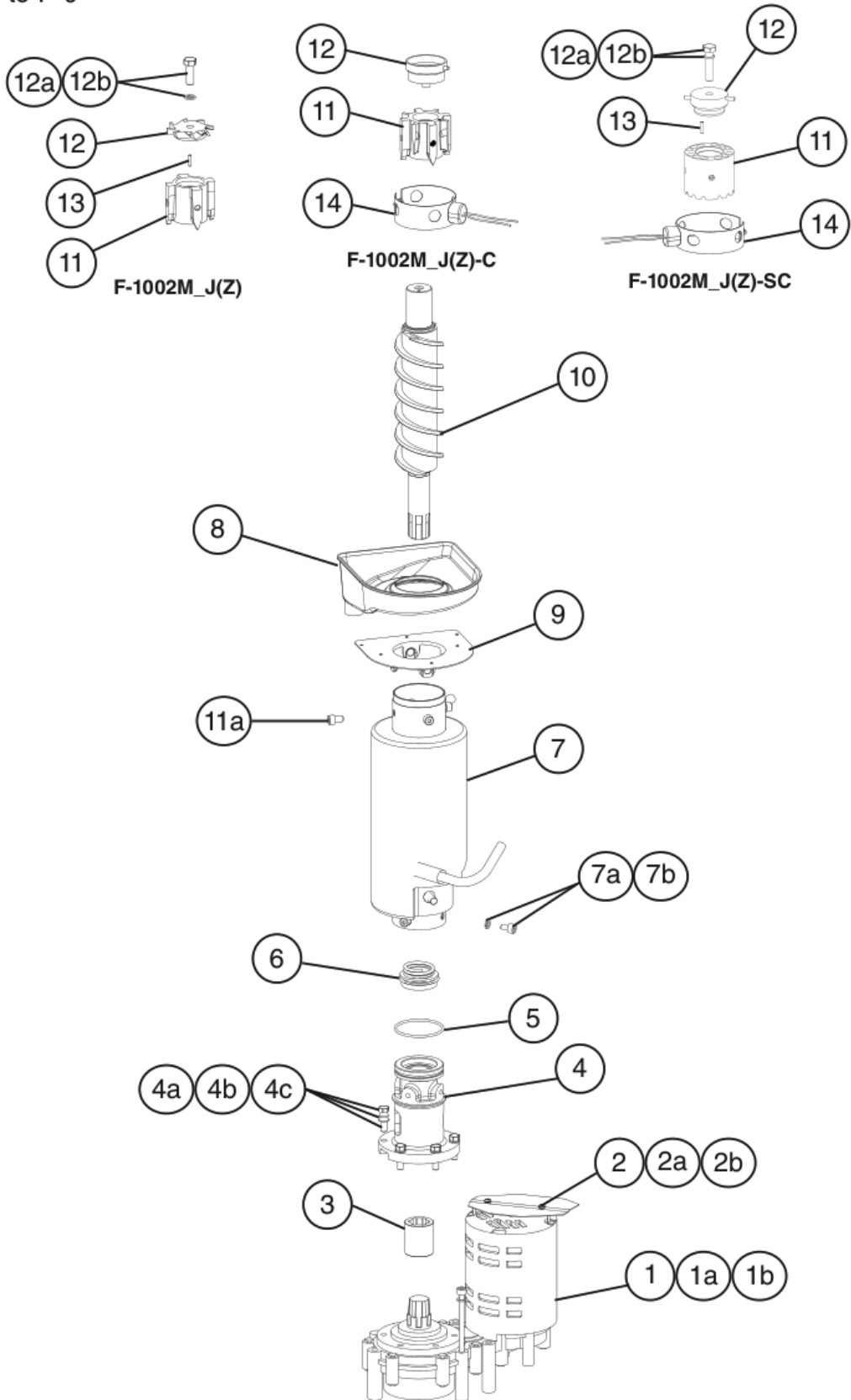

Title: B. Icemaking Unit Model: F-1002M_J(Z)(-C)(-SC)													
Index No.	Description	Material or Model Number	Part Number	Required Number									
				F-0 to K-0	L-0	L-1	L-2 to N-0	N-1 to P-0					
1	Gear Motor		4A2007-01	1	-								
			4A6946-01		1	-		1					
			4A2007-01				1	1	1				
1a	Socket Head Cap Screw		7S12-0811	3	3	3	3	3					
1b	Split Lock Washer		7L22-0800	3	3	3	3	3					
2	Gear Motor Barrier		4A4029-01	1	1	-							
			3B1054-01				1	1	1				
2a	Truss Head Screw		7C32-0408	2	2	2	2	2					
2b	Washer		4A5268-01	2	2	2	2	2					
3	Spline Coupling		414137-01	1	1	1	1	1					
4	Housing		2A1977G01	1	-								
			3B0186G01			1	1	1	1				
4a	Hex Head Bolt	8x30, SS	7B02-0830	6	6	6	6	6					
4b	Plain Washer		7W22-0800	6	6	6	6	6					
4c	Split Lock Washer		7L22-0800	6	6	6	6	6					
5	O-Ring		4A4755-02	1	1	1	1	1					
6	Mechanical Seal		432492-01	1	1	1	-						
			432492-03						1				
7	Evaporator		2A7209G01	1	1	1	1	1					
7a	Socket Head Cap Screw	8x12, SS	7S12-0812	4	4	4	4	4					
7b	Split Lock Washer		7L22-0800	3	3	3	3	3					
8	Drip Pan		2A7187-01	1	1	1	1	1					
9	Flange		352713-01	1	1	1	1	1					
10	Auger		120863G02	1	1	1	1	1					
11	Extruding Head	F-1002M_J(Z)	3A2175G01	1	1	1	1	1					
		F-1002M_J(Z)(-C)	3A2176G01	1	1	1	1	1					
		F-1002M_J(Z)(-SC)	3A9761G01	1	1	1	1	1					
11a	Seal Bolt	F-1002M_J(Z)(-C)	P01768-02	4	4	4	4	4					
		F-1002M_J(Z)(-SC)	4A6172A01	4	4	4	4	4					
12	Cutter	F-1002M_J(Z)	3A1395-02	1	1	1	1	1					
		F-1002M_J(Z)(-C)	427183G01	1	1	1	1	1					
		F-1002M_J(Z)(-SC)	4A6209G01	1	1	1	1	1					
12a	Hex Head Bolt	F-1002M_J(Z) 10x30, SS	7B02-1030	1	1	1	1	1					
		F-1002M_J(Z)(-SC) 10x45, SS	7B02-1045	1	1	1	1	1					
12b	Split Lock Washer	F-1002M_J(Z)(-SC) M10, SS	7L22-1000	1	1	1	1	1					
13	Dowel Pin	F-1002M_J(Z)(-SC) 4x16, SS	713S-0416	1	1	1	1	1					
14	Evaporator Heater	F-1002M_J(Z)(-C)(-SC)	4A2292-01	1	1	1	1	1					

C. Water Circuit
F-1002M_J(Z)(-C)(-SC)
F-0 to P-0

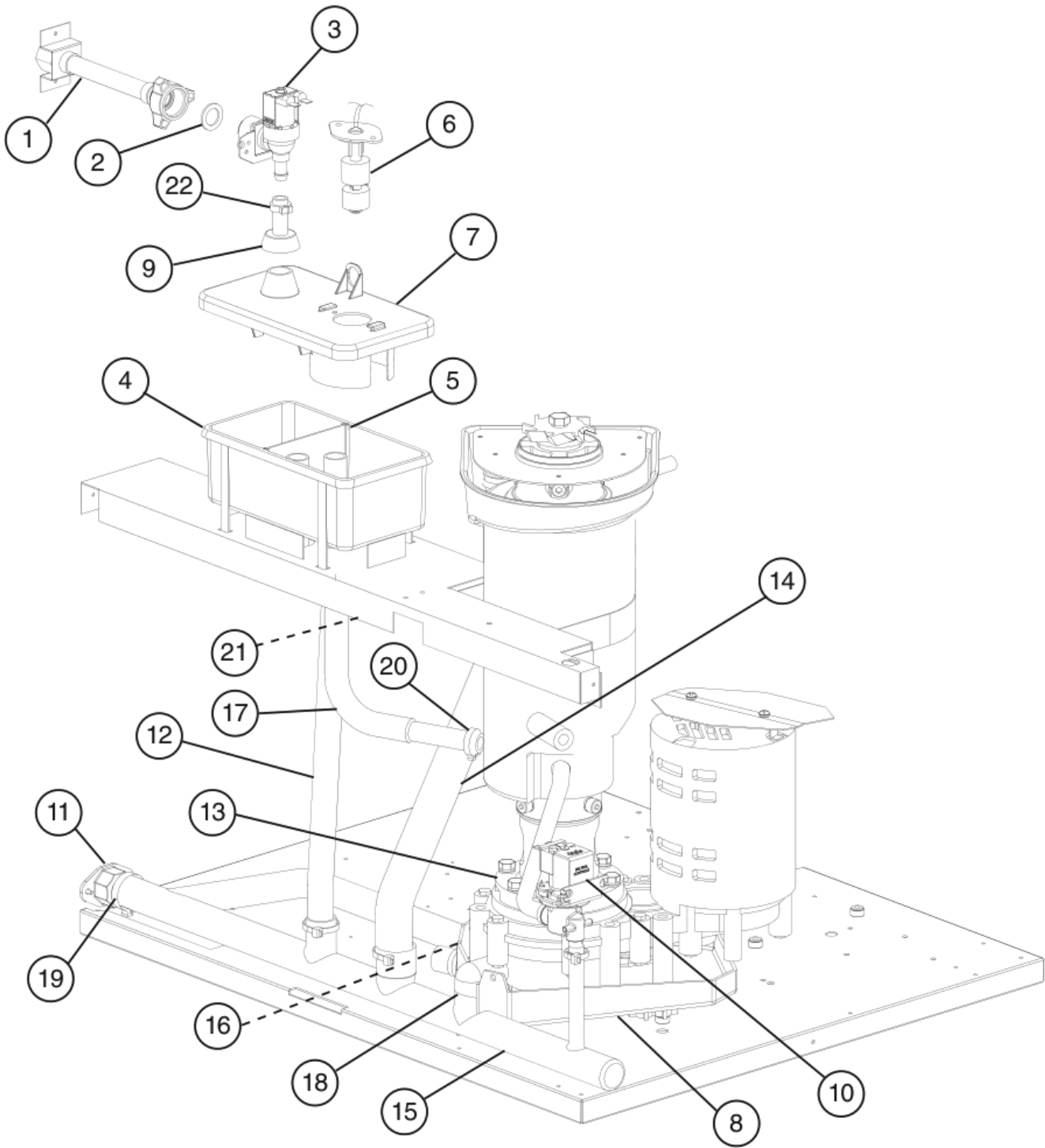

Title: C. Water Circuit Model: F-1002M_J(Z)(-C)(-SC)												
Index No.	Description	Material or Model Number	Part Number	F-0 to P-0	Required Number							
1	Water Supply Pipe		4A0891G02	1								
2	Washer		413854-03	1								
3	Inlet Water Valve		4A5309-01	1								
4	Reservoir		2A0753-01	1								
5	Reservoir Separator		4A1255-01	1								
6	Float Switch		435490-01	1								
7	Reservoir Cover		214810-01	1								
8	Drain Pan		323765G02	1								
9	Reservoir Inlet		4A0869-01	1								
10	Drain Valve		4A2772-02	1								
11	Drain Fitting		4A5528-01	1								
12	Vinyl Hose	L=375 mm	7725-1923	1								
13	Silicone Hose	L=185 mm	7730 3896	1								
14	Vinyl Hose	L=460 mm	4A0658L01	1								
15	Drain Hose		3A8170-01	1								
16	Vinyl Hose	L=30 mm	7725-1923	1								
17	Reservoir Hose		4A1165-06	1								
18	Elbow		4A5624-01	1								
Clamps												
19	Hose Clamp	26-30mm	4A2017-02	1								
20	Hose Clamp	17-20mm	4A2017-05	1								
21	Hose Clamp	19-22mm	4A2017-06	1								
22	Hose Clamp	14-15mm	4A2017-08	1								

D. Control Box Assembly
F-1002M_J(Z)(-C)(-SC)
F-0 to P-0

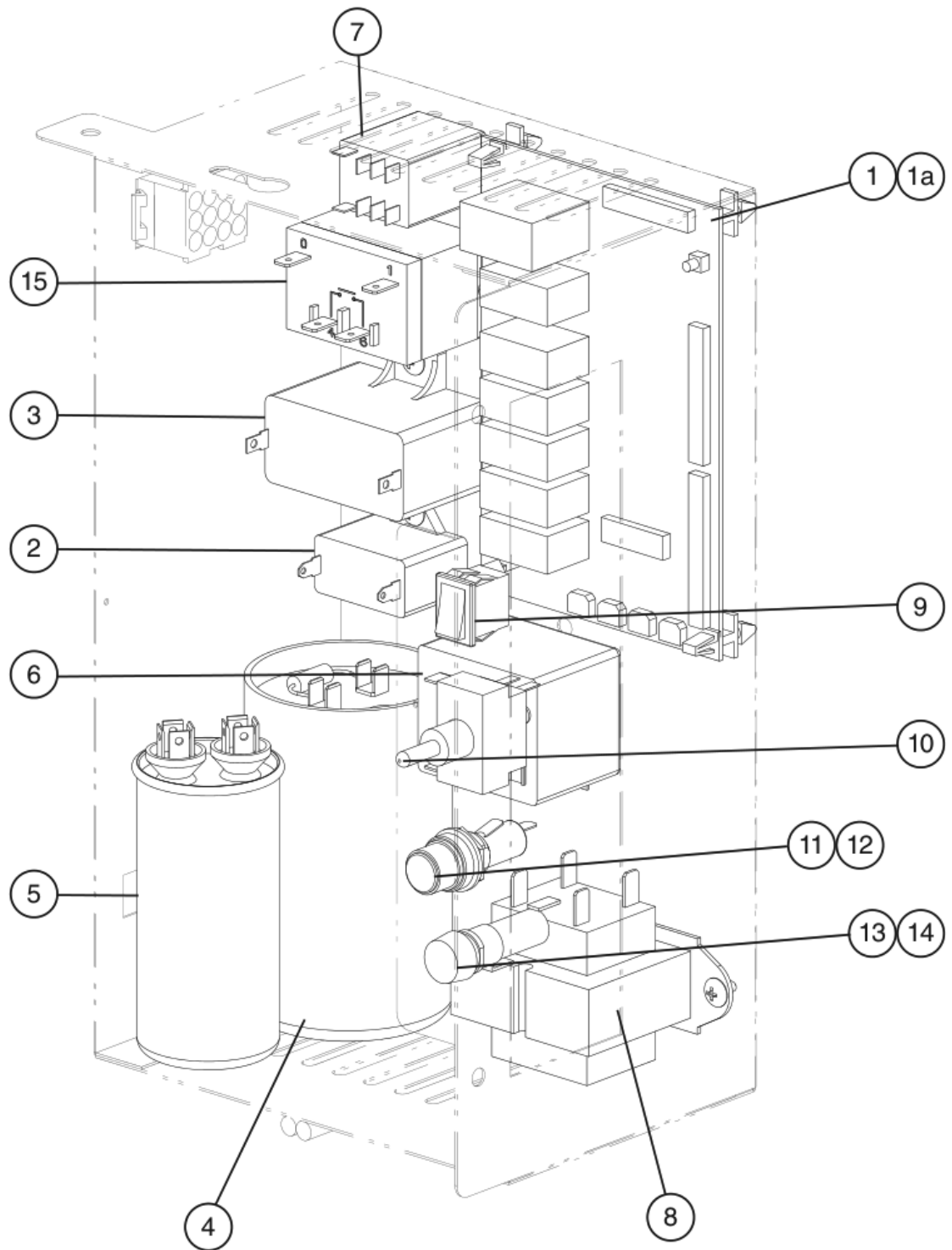

Title: D. Control Box Assembly Model: F-1002M_J(Z)(-C)(-SC)											
Index No.	Description	Material or Model Number	Part Number	Required Number							
				F-0 to J-1	J-2 to N-0	N-2 to P-0					
1	Control Board		2A9093-01	1	1	-					
			2A9874-01			1					
1a	Control Board Support		4A0336-03	4	4	4					
2	Fan Motor Capacitor	F-1002MAJ(-C)(SC) 5MFD, 250VAC	443192-02	1	-						
			4A6435-02		1	1					
3	Gear Motor Capacitor	24MFD, 250VAC	4A2273-01	1	1	1					
4	Start Capacitor (all except F-1002MLJ(-C))	340-408MFD, 250VAC	3A0076-24	1	1	1					
5	Run Capacitor (all except F-1002MLJ(-C))	40MFD, 370VAC	3A2005-13	1	1	1					
6	Start Relay (all except F-1002MLJ(-C))		4A1107-22	1	1	1					
7	Compressor Control Relay	110/120VAC	406132-07	1	-						
			4A6558-01		1	1					
8	Control Transformer		4A0557-01	1	1	1					
9	Control Switch		4A0558-01	1	1	1					
10	Power Switch		4A2332-01	1	1	1					
11	Fuse Holder (control)		4A5443-01	1	1	1					
12	Fuse (control)	AGC-1A, 250VAC	4A0893-01	1	1	1					
13	Fuse Holder (gear motor)		4A6101-01	1	1	1					
14	Fuse (gear motor)	GMD-3A, 250VAC	4A0893-06	3	3	3					
15	Compressor Relay (all except F-1002MLJ(-C))	115VAC	4A3140-01	1	1	1					

E. Accessories & Labels
F-1002M_J(Z)(-C)(-SC)
 F-0 to P-0

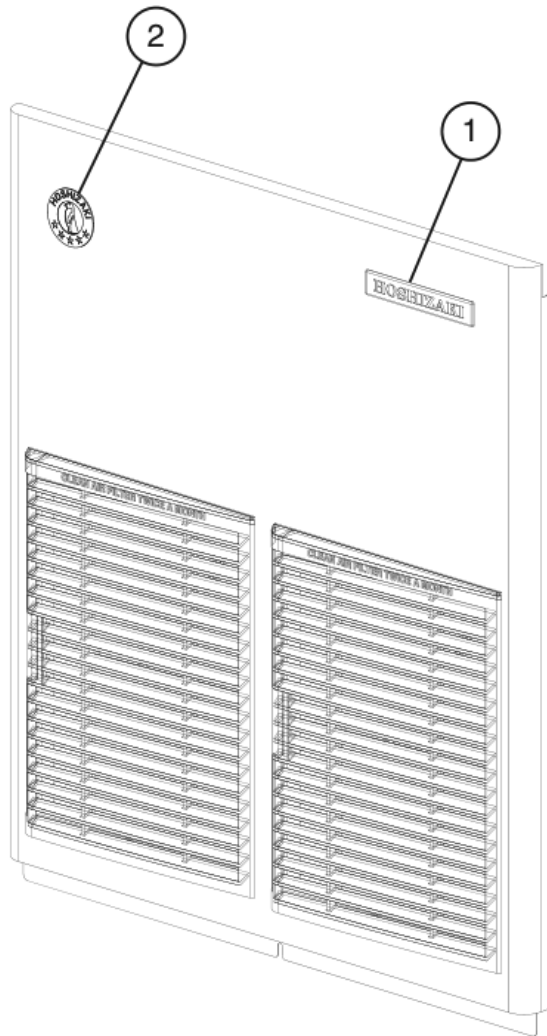

Title: E. Accessories & Labels Model: F-1002M_J(Z)(-C)(-SC)											
Index No.	Description	Material or Model Number	Part Number	Required Number							
				F-0 to P-0							
1	Hoshizaki Emblem Label		4A0560-01	1							
2	Penguin Label		475552L02	1							
3	Universal Brace		4A0363-01	2							
3a	Hex Bolt	5x12, SS	7B02-0512	2							