



**HOSHIZAKI**

**MODULAR FLAKER**

**MODEL**

**F-1101AWU**

**PARTS LIST**

ISSUED: JUL.1, 1985

REVISIED: APR. 19,1989

PRINTED: MAY 2, 1995

ITEM NO: 71038

NO.	U2CA	717
EFFECTIVE:	JUL. 1, 1985	
REVISED:	APR. 19, 1989	



# PARTS LIST

# MODULAR FLAKER F-1101AWU

E-1	JUL.	1	985
F-1	MAY	1	986
F-2	NOV.	1	986
G-1	DEC.	1	986
G-2	SEP.	1	987

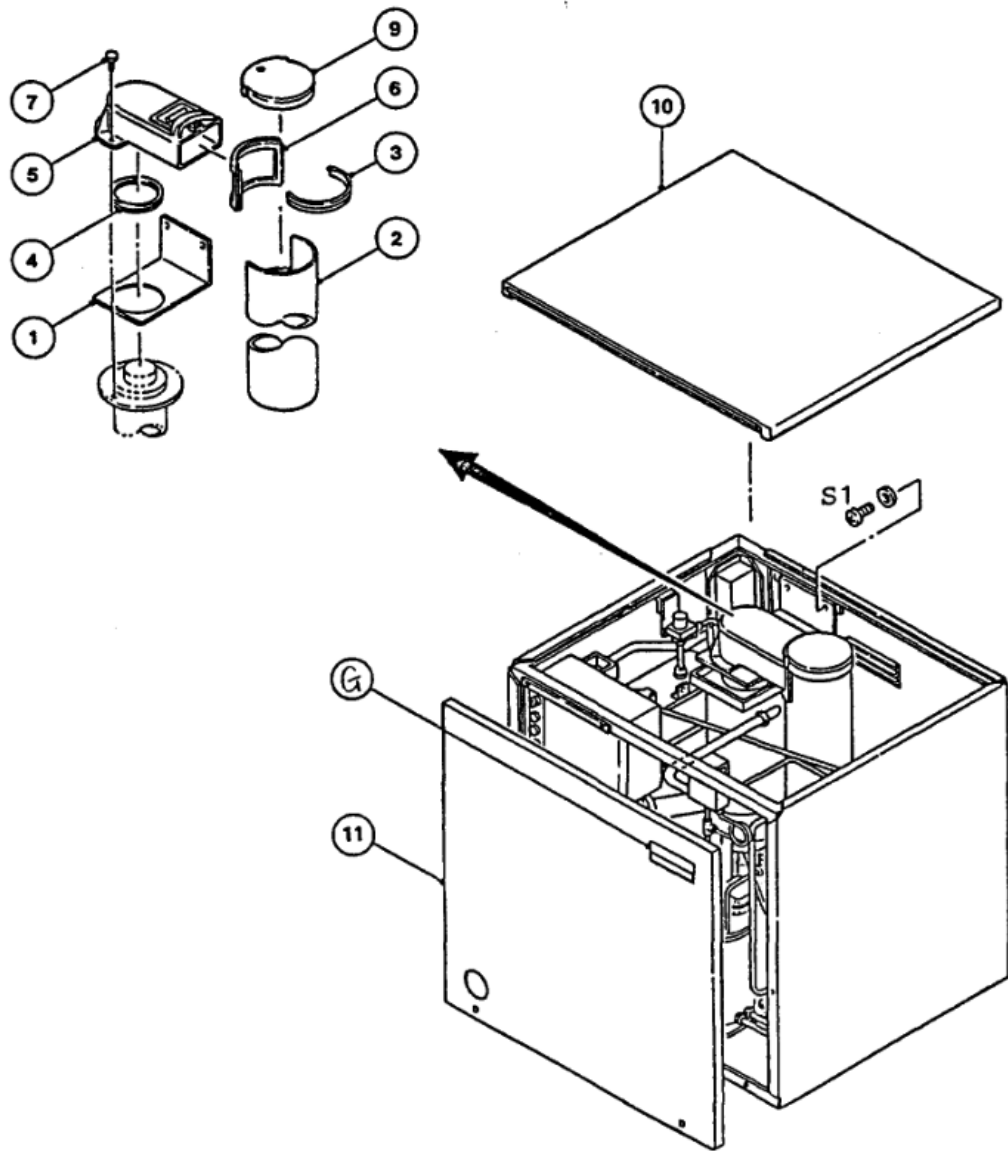

FASTENER

S1 - TRUSS HEAD MACHINE SCREW, STAINLESS, M5x12

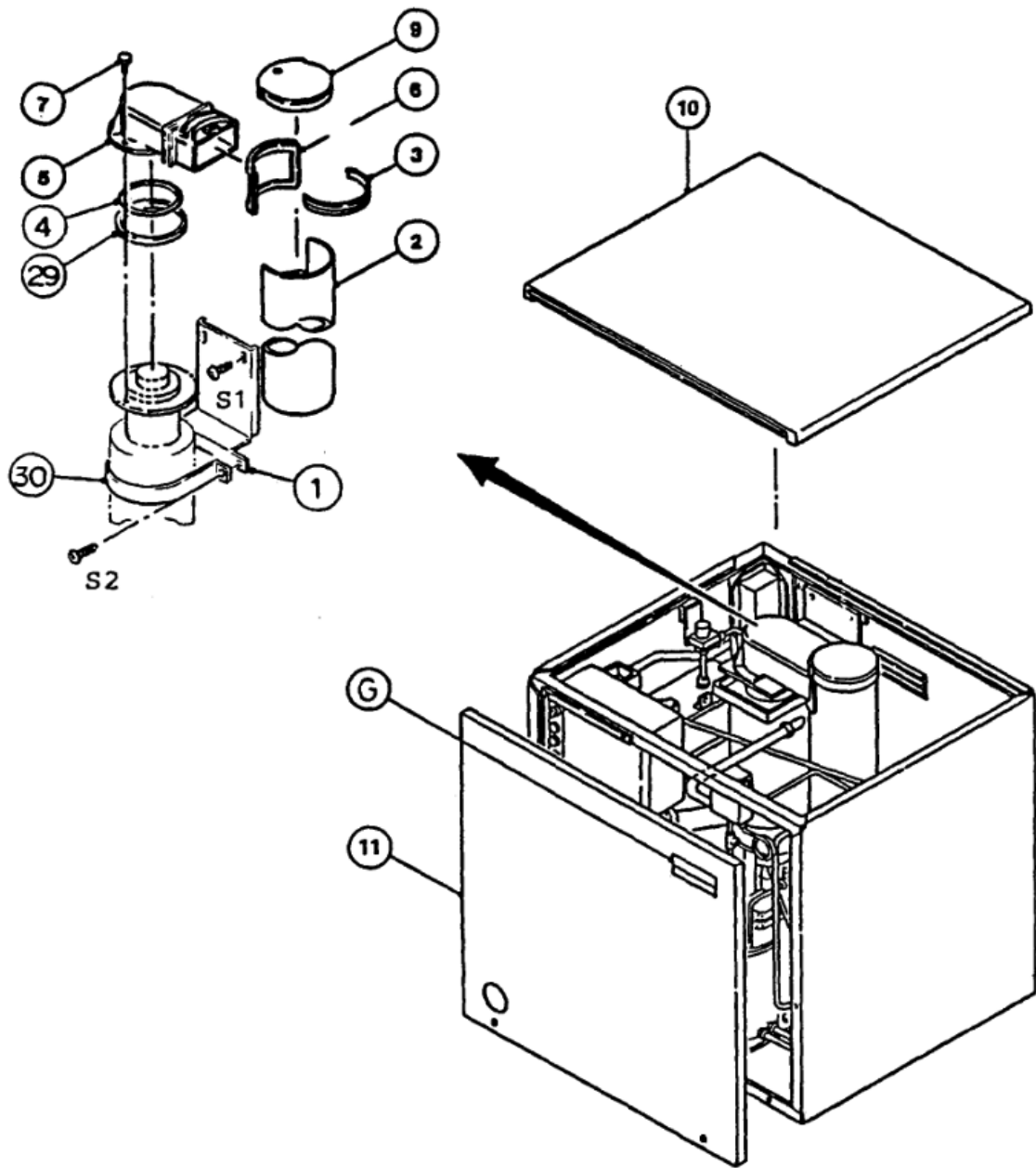

FASTENER

S1 - TRUSS HEAD MACHINE SCREW. STAINLESS, M5x12

S2 - TRUSS HEAD MACHINE SCREW. M4x8

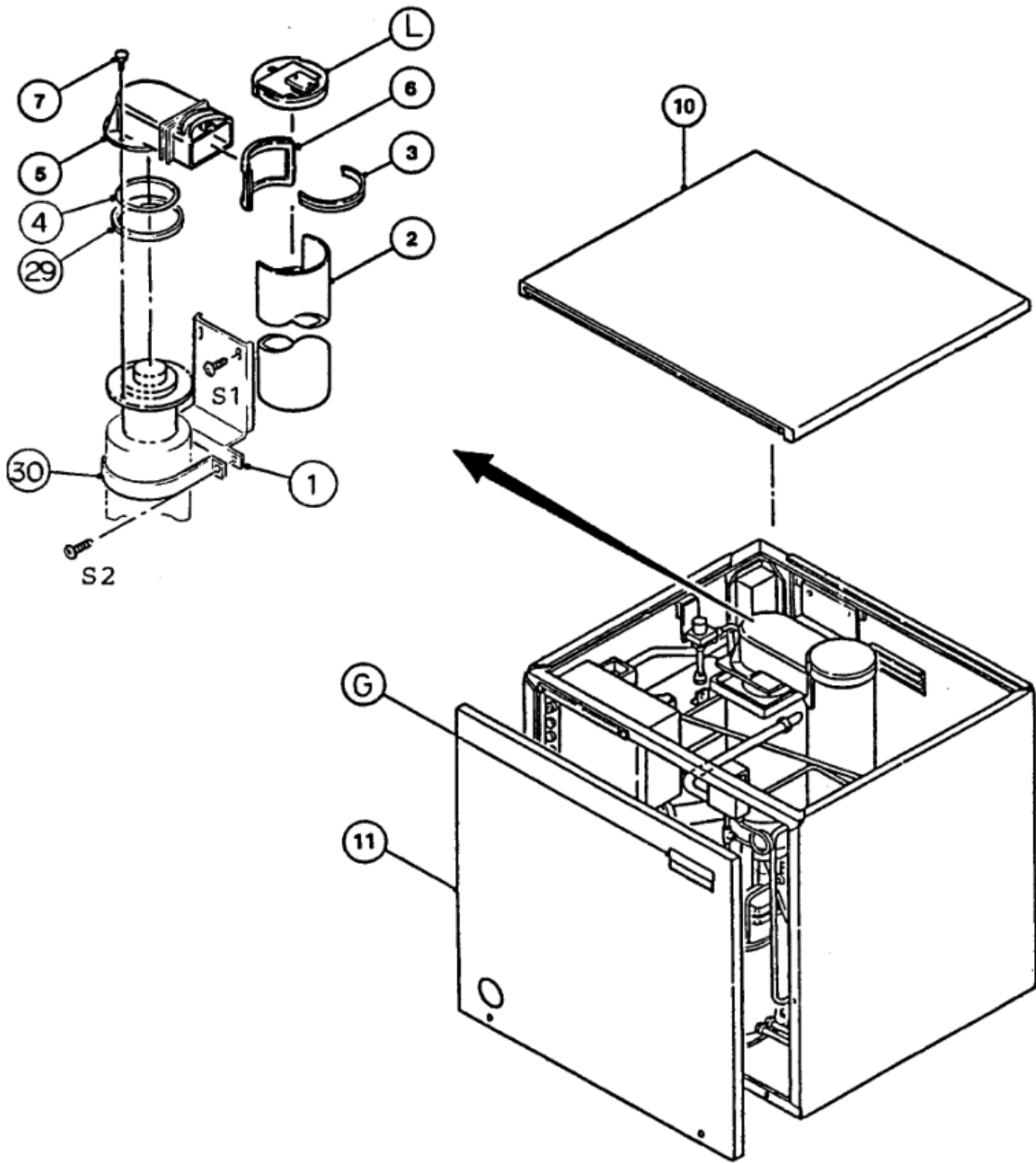

FASTENER

- S1 - TRUSS HEAD MACHINE SCREW. STAINLESS, M5x12
- S2 - TRUSS HEAD MACHINE SCREW, M4x8



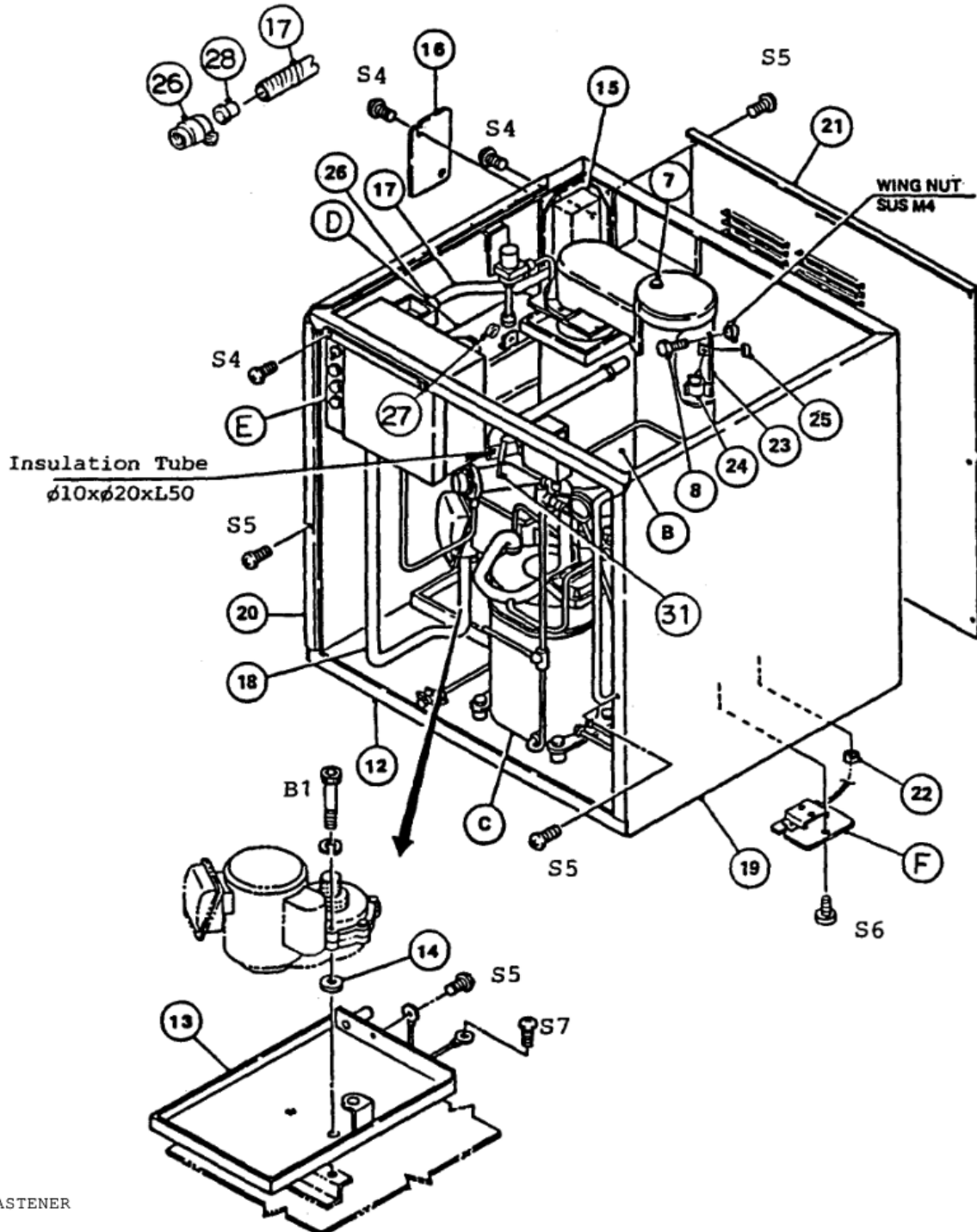

## FASTENER

- S4 - TRUSS HEAD MACHINE SCREW, M4x8  
 S5 - TRUSS HEAD MACHINE SCREW, STAINLESS, M4x6  
 S6 - TRUSS HEAD MACHINE SCREW, STAINLESS, M4x8  
 S7 - TRUSS HEAD MACHINE SCREW, M4x6  
 B1 - HEXAGON SOCKET CAP BOLT, STAINLESS. M8x90

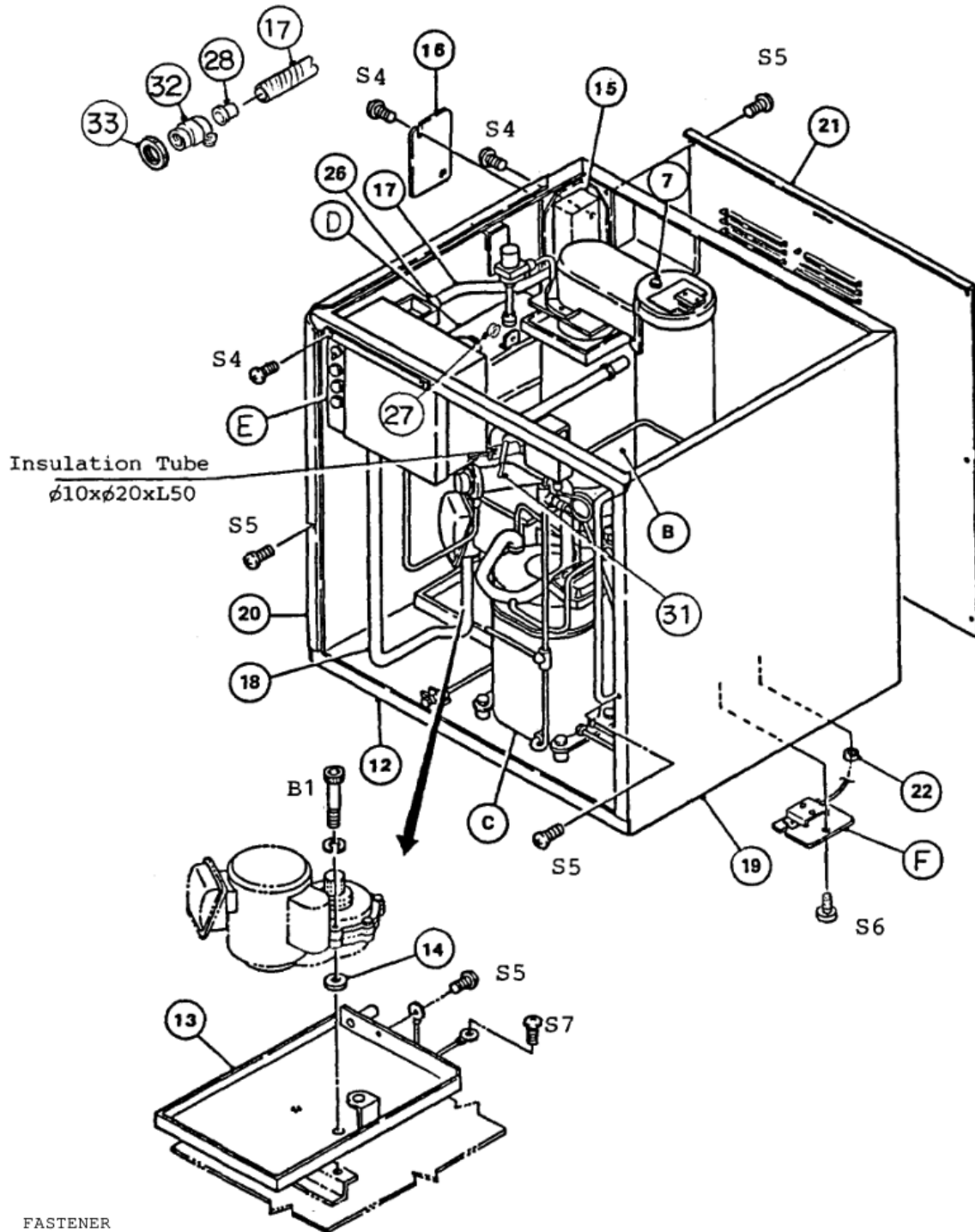

MODEL F-1101AMU		TITLE A. GENERAL ASSEMBLY			REQ'D NUMBER				
INDEX NO.	DESCRIPTION	MATERIAL OR MODEL NUMBER	PART NUMBER	E-1	F-1	F-2	G-1	G-2	
				B	EVAPORATOR ASSEMBLY	-	208112A04 319958A03	1	-
C	REFRIGERATION UNIT	-	103118A01	1	1	1	1	1	
D	HATER CIRCUIT ASSEMBLY	-	103078A02 103078A03	1	-	1	1	1	
E	CONTROL BOX ASSEMBLY	-	208273A03 208273A04	1	1	-	1	1	
F	BIN SWITCH ASSEMBLY	-	317649A01	1	1	1	1	1	
G	LABEL LOCATION	-	208419A05 208419A06	1	1	1	1	- 1	
1	Bracket - Evaporator	S.S	425251-01	1	-	1	-		
		G.S	431735-01				1	1	
2	Chute	PE	318613-01 320555-01	1	1	1	-	1 1	
3	Packing - Chute	EPDM	425255-01	1	1	1	1	1	
4	Packing - Cylinder	EPDM	427151-03	1	1	1	-		
	°O" Ring	G95	7616-G095				1	1	
5	Spout	ABS	103382G01	1	1	1	-		
		PC	103932G01				1	1	
6	Packing - Spout	EPDM	315722-01	1	1	1	1	1	
7	Thumbscrew	S.S, ABS	415949G03	4	4	4	4	4	
8	Thumbscrew	S.S, ABS	415949G04	2	2	2	2	2	
9	Cover - Chute	ABS	209817G01	1	1	1	1	1	
10	Top Panel	S.S	315750G01	1	1	1	1	1	
11	Front Panel	S.S	315937-01 315937-02	1	1	1	-	1 1	
12	Frame	G.S	315778G06	1	1	1	1	1	
13	Drip Pan	S.S	317168G01	1	1	1	1	1	
14	Washer	PVC	422916-01	3	3	3	3	3	
15	Junction Box	No.6001	421587-01	1	1	1	1	1	
16	Cover - Junction Box	G.S	420594-01	1	1	1	1	1	
17	Conduit	-	429313-02	1	1	1	1	1	
18	Conduit	-	429313-01	1	1	1	1	1	
19	Side Panel (Right)	S.S	316033G01	1	1	1	1	1	

MODEL		TITLE						
F-1101AWU		A. GENERAL ASSEMBLY						
INDEX NO.	DESCRIPTION	MATERIAL OR MODEL NUMBER	PART NUMBER	REQ'D NUMBER				
				H-0	J-1	J-2		
B	EVAPORATOR ASSEMBLY	-	319958A03	1	1	1		
C	REDRIGERATION UNIT	-	103118A01	1	1	-		
			103118A02			1		
D	WATER CIRCUIT ASSEMBLY	-	103078A03	1	1	1		
E	CONTROL BOX ASSEMBLY	-	208273A04	1	-			
			213117A01		1	1		
F	BIN SWITCH ASSEMBLY	-	317679A01	1	1	1		
G	LABEL LOCATION	-	208419A06	1	-			
			213149A01		1	1		
L	SPOUT CONTROL ASSEMBLY	-	323313A01		1	1		
1	Bracket - Evaporator	G.S	431735-01	1	1	1		
2	Chute	PE	320555-01	1	-			
			315723-01		1	1		
3	Packing - Chute	EPDM	425255-01	1	1	1		
4	"O" Ring	G95	7616-G095	1	1	1		
5	Spout	PC	103932G01	1	1	1		
6	Packing - Spout	EPDM	315722-01	1	1	1		
7	Thumbscrew	S.S, ABS	415949G03	4	4	4		
8	Thumbscrew	S.S, ABS	415949G04	2	2	2		
9	Cover - Chute	ABS	209817G01	1	1	1		
10	Top Panel	S.S	315750G01	1	1	1		
11	Front Panel	S.S	315937-02	1	1	1		
12	Frame	G.S	315778G06	1	-			
			315778G09		1	1		
13	Drip Pan	S.S	317168G01	1	1	1		
14	Washer	PVC	422916-01	3	3	3		
15	Junction Box	No.6001	421587-01	1	1	1		
16	Cover - Junction Box	G.S	420594-01	1	1	1		
17	Conduit	-	429313-02	1	1	1		
18	Conduit	-	429313-01	1	1	1		
19	Side Panel (Right)	S.S	316033G01	1	1	1		

MODEL		TITLE						
F-1101AWU		A. GENERAL ASSEMBLY						
INDEX NO.	DESCRIPTION	MATERIAL OR MODEL NUMBER	PART NUMBER	REQ'D NUMBER				
				E-1	P-1	F-2	G-1	G-2
20	Side Panel (Left)	S.S	315748G02	1	1	1	1	1
21	Rear Panel	S.S	316034-01	1	1	1	1	1
22	Bushing	SB-437-5	420470-07	1	1	1	1	1
23	Bracket - Thermostat	S.S	318612-01	1	1	1	1	1
24	Clip	PA No.96	429285-01	2	2	2	2	2
25	Bushing - Capillary Tube	EPDM	425307-01	1	1	1	1	1
26	Fitting - Conduit, Straight	No.13-16	425316-01	4	4	4	4	4
27	Bushing	SR-30-1	420472-03	1	1	1	1	1
28	Collar	Steel	430335-01		4	4	4	4
29	Ring	PA	431736-01				1	1
30	Strap	G.S	431737-01				1	1

MODEL F-1101AWU		TITLE A. GENERAL ASSEMBLY						
INDEX NO.	DESCRIPTION	MATERIAL OR MODEL NUMBER	PART NUMBER	REQ'D NUMBER				
				H-0	J-1			
20	Side Panel (Left)	S.S	315748G02	1	1			
21	Rear Panel	S.S	316034-01	1	1			
22	Bushing	SB-437-5	420470-07	1	1			
23	Bracket - Thermostat	S.S	318612-01	1	-			
24	Clip	PA No.96	429285-01	2	-			
25	Bushing - Capillary Tube	EPDM	425307-01	1	-			
26	Fitting - Conduit, Straight	No.13-16	425316-01	4	-			
27	Bushing	SR-30-1	420472-03	1	1			
28	Collar	Steel	430335-01	4	4			
29	Ring	PA	431736-01	1	1			
30	Strap	G.S	431737-01	1	1			
31	Tie	CV-150	7920-0003	1	1			
32	Fitting - Conduit	NS-1621	435753-01		4			
33	Nut	t3.6	435753F01		4			

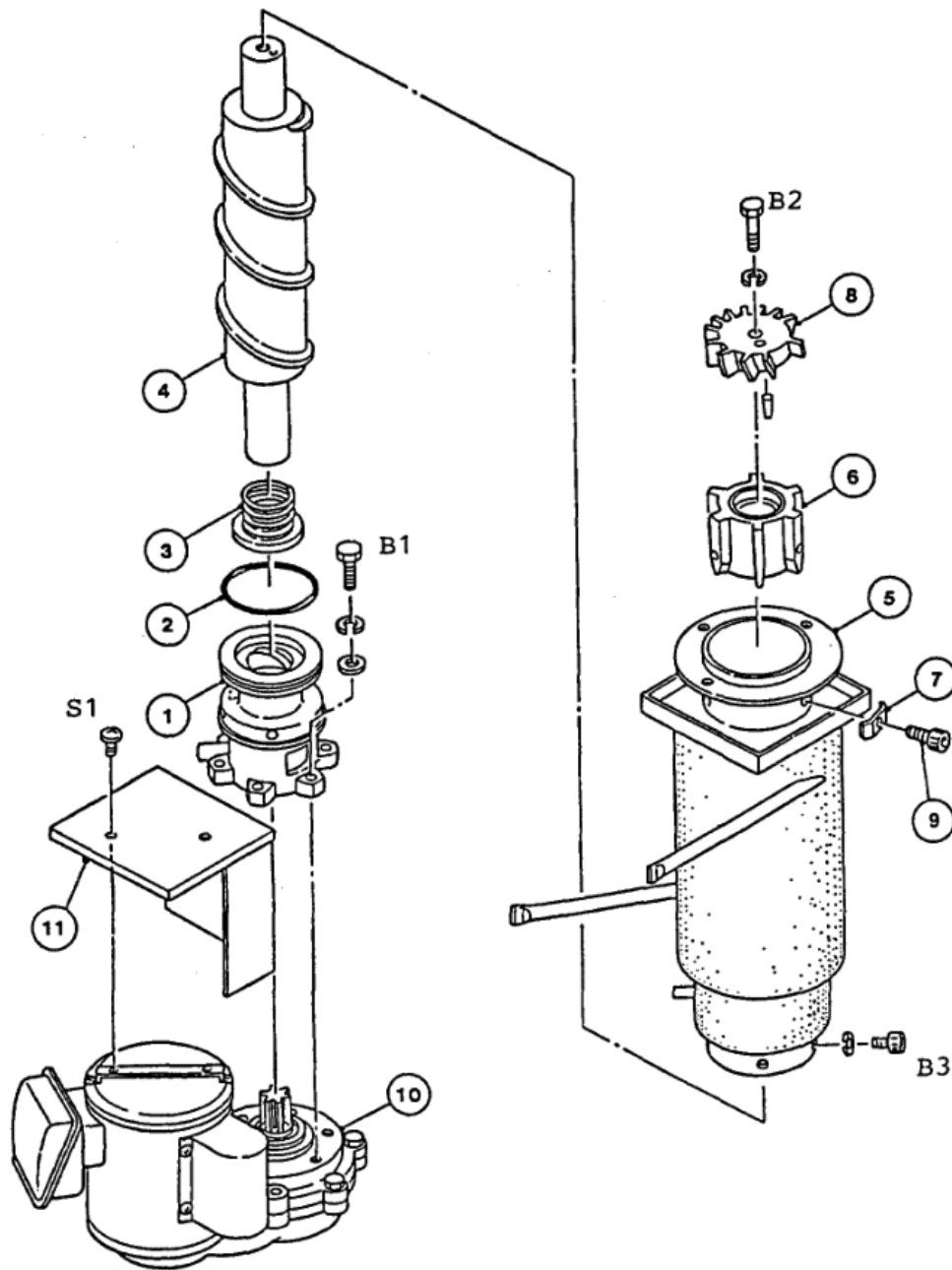

FASTENER

- SI - TRUSS HEAD MACHINE SCREW, M4x8
- B1 - HEXAGON HEAD BOLT, STAINLESS, M8x30
- B2 - HEXAGON HEAD BOLT, STAINLESS, M10x30
- B3 - HEXAGON SOCKET CAP BOLT, STAINLESS, M10x20

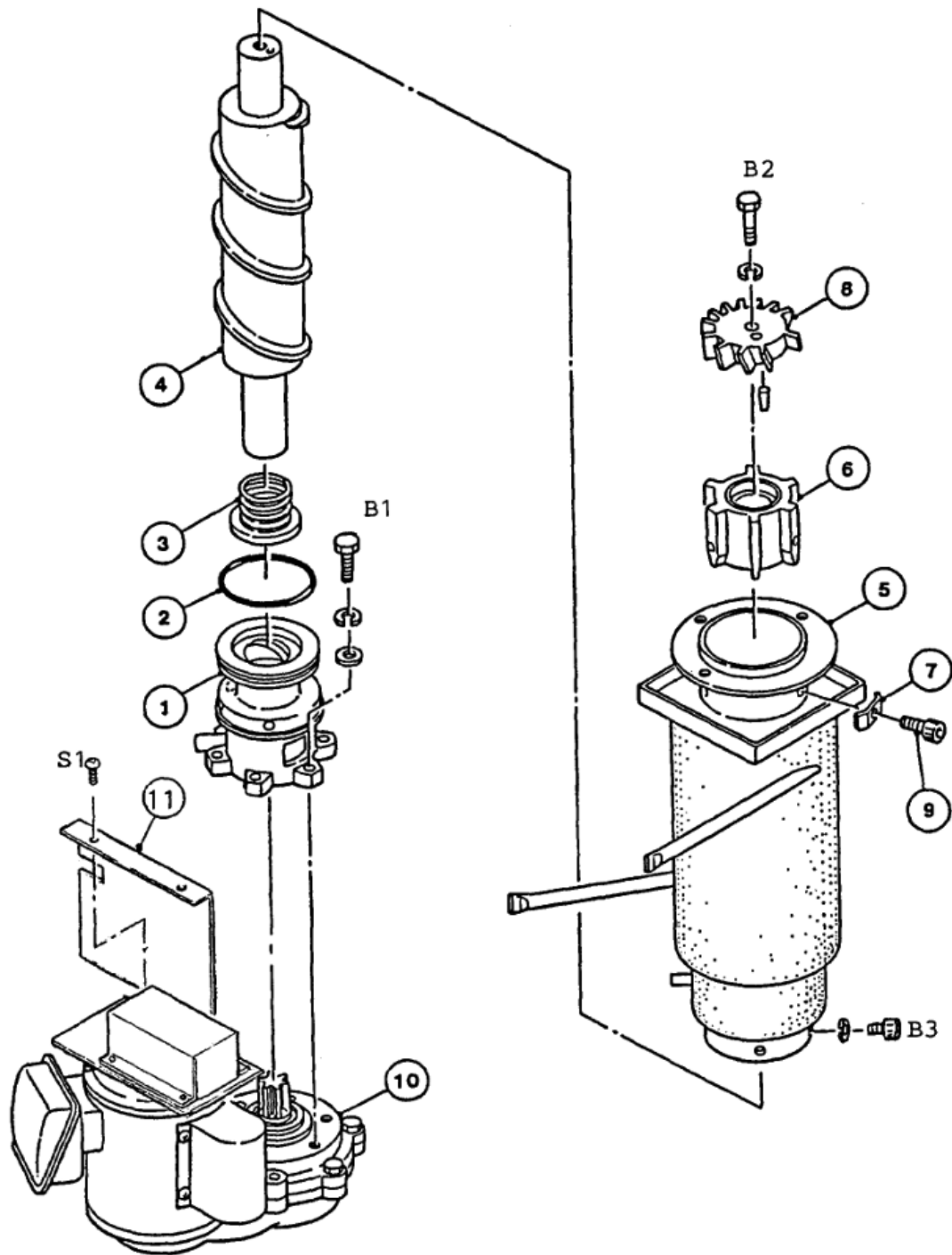

## FASTENER

- S1 - TRUSS HEAD MACHINE SCREW, M4x8  
 B1 - HEXAGON HEAD BOLT, STAINLESS, M8x30  
 B2 - HEXAGON HEAD BOLT, STAINLESS, M10x40  
 B3 - HEXAGON SOCKET CAP BOLT, STAINLESS, M10x20

MODEL		TITLE							
P-1101AWU		B. EVAPORATOR ASSEMBLY							
INDEX NO.	DESCRIPTION	MATERIAL OR MODEL NUMBER	PART NUMBER	REQ'D NUMBER					
				E-1	F-1	F-2	G-1	G-2	
1	Bearing (Lower)	-	315732G02	1	1	1	1	1	
2	"O" Ring	G90	7616-G090	1	1	1	1	1	
3	Mechanical Seal	HG9A-MN	420692-01	1	1	1	1	-	
		HK9A-MN	432493-01					1	
4	Auger	S.S	209744G01	1	1	1	-		
			211062G01				1	1	
5	Evaporator	-	425273G04	1	1	1	1	1	
6	Extruding Head	S.S	208117G02	1	1	1	1	1	
7	Hasher	S.S	425277-01	3	3	3	3	3	
8	Cutter	S.S	315734-01	1	1	1	1	1	
9	Socket Head Cap Screw	S.S, M10	429121-02	3	3	3	.3	3	
10	Gear Motor	MGZ2200UL-160	2U0044-01	1	-				
			432068-01		1	1	1	1	
11	Cover - Gear Motor	G.S	315841G01	1	-				
			431532-01		1	1	1	1	

MODEL		TITLE						
P-1101AWU		B. EVAPORATOR ASSEMBLY						
INDEX NO.	DESCRIPTION	MATERIAL OR MODEL NUMBER	PART NUMBER	REQ'D NUMBER				
				H-0	J-1			
1	Bearing (Lower)	-	315732G02	1	1			
2	"O" Ring	G90	7616-G090	1	1			
3	Mechanical Seal	HK9A-MN	432493-01	1	1			
4	Auger	S.S	211062G01	1	1			
5	Evaporator	-	425273G04	1	1			
6	Extruding Head	S.S	208117G02	1	1			
7	Hasher	S.S	425277-01	3	3			
8	Cutter	S.S	315734-01	1	1			
9	Socket Head Cap Screw	S.S, M10	429121-02	3	3			
10	Gear Motor	MGZ2200UL-160	432068-01	1	1			
11	Cover - Gear Motor	G.S	431532-01	1	1			

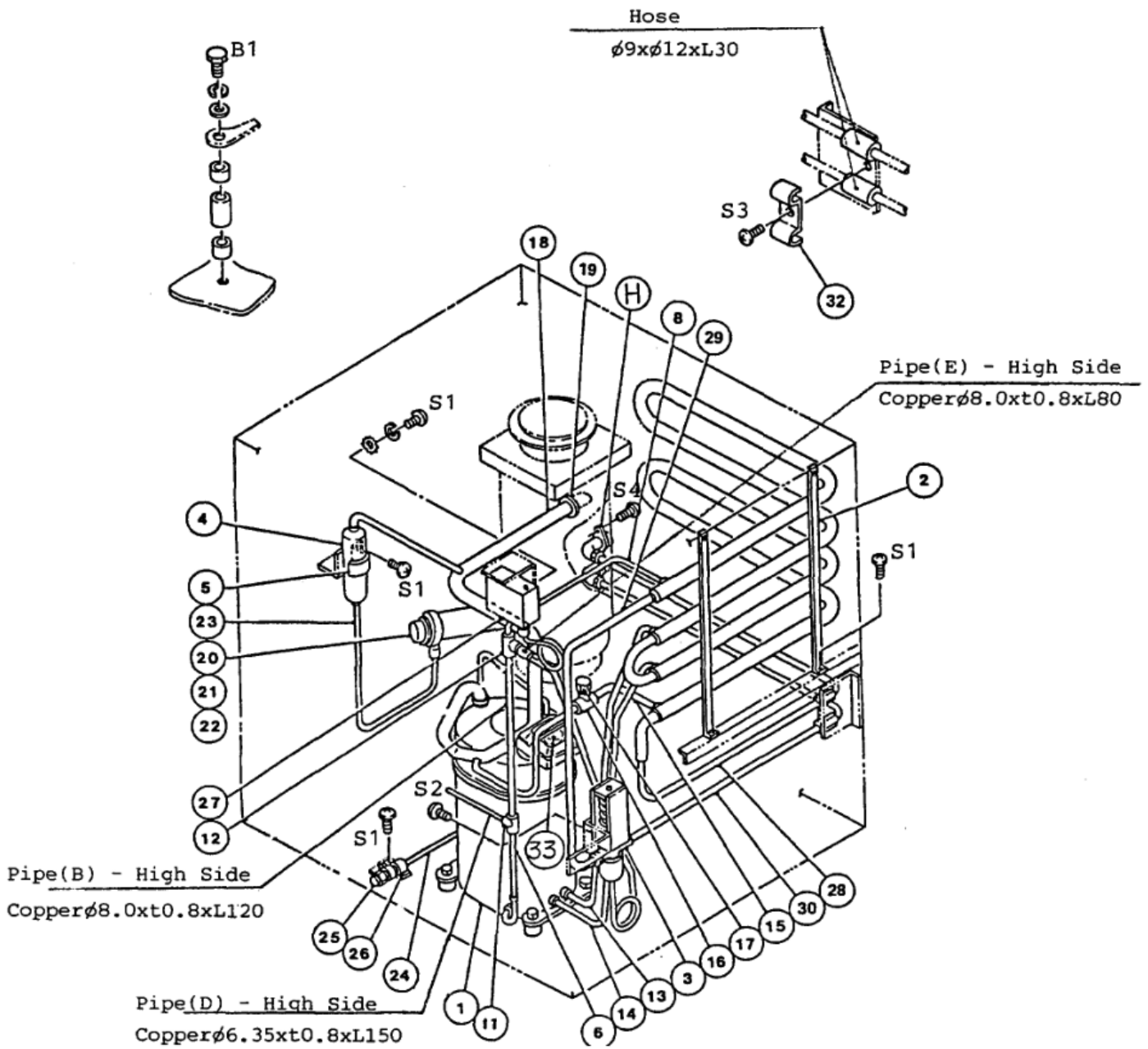

FASTENER

- S1 - TRUSS HEAD MACHINE SCREW, M4x8
- S2 - TRUSS HEAD MACHINE SCREW, M4x6
- S3 - TRUSS HEAD TAPPING SCREW, M4x8
- S4 - TRUSS HEAD MACHINE SCREW, STAINLESS, M4x8
- B1 - HEXAGON HEAD BOLT, M8x45

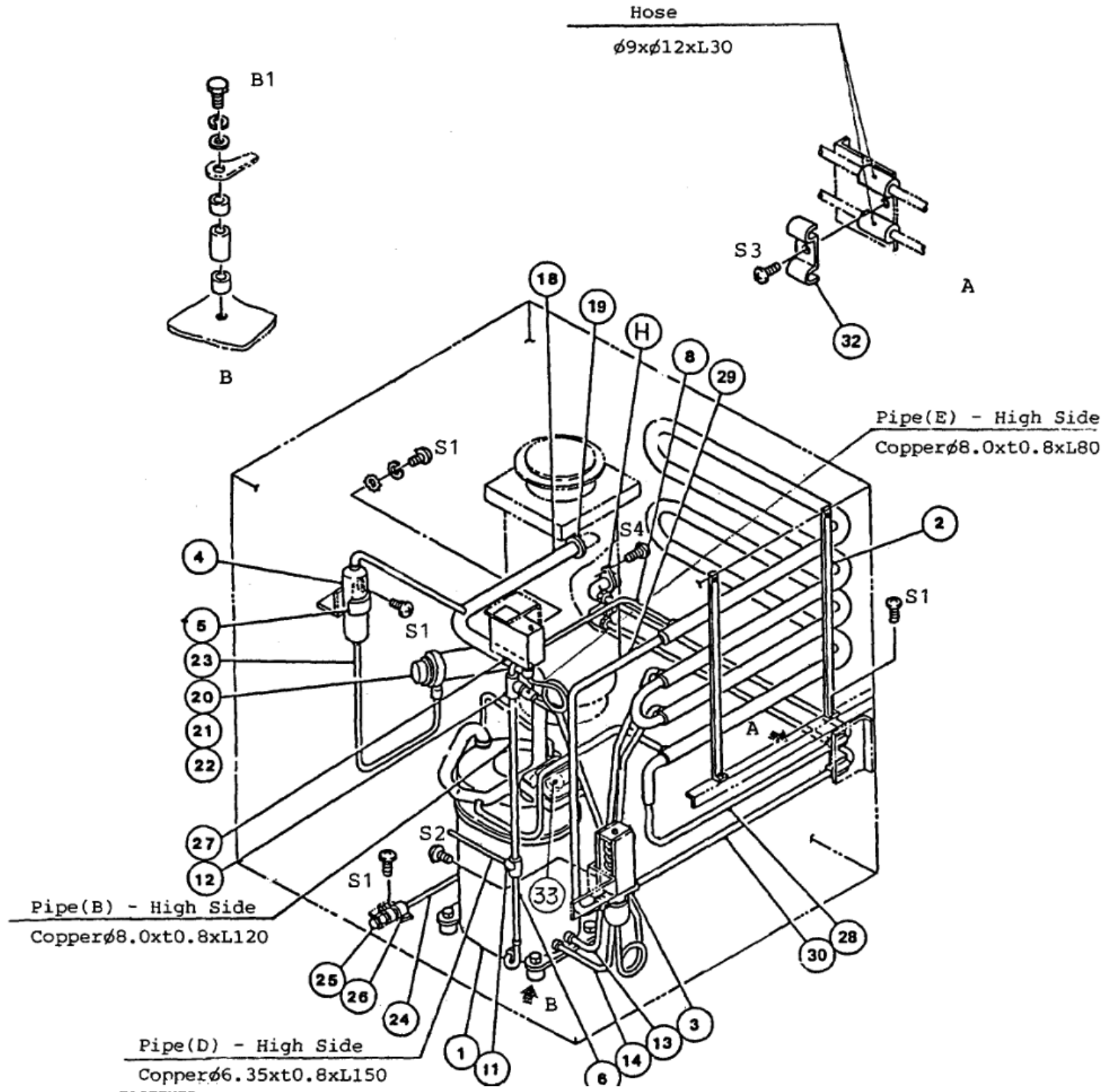

- S1 - TRUSS HEAD MACHINE SCREW, M4x8
- S2 - TRUSS HEAD MACHINE SCREW, M4x6
- S3 - TRUSS HEAD TAPPING SCREW, M4x8
- S4 - TRUSS HEAD MACHINE SCREW, STAINLESS, M4x8
- B1 - HEXAGON HEAD BOLT, M8x45

MODEL F-1101AWU		TITLE C. REFRIGERATION UNIT			REQ'D NUMBER				
INDEX NO.	DESCRIPTION	MATERIAL OR MODEL NUMBER	PART NUMBER	REQ'D NUMBER					
				E-1	F-1	F-2	G-1	G-2	
H	FITTING (U) ASSEMBLY	(S-0382)	314347A01	2	2	2	2	2	
1	Compressor	KL100TD-3	2U0043-01	1	1	1	1	1	
2	Condenser - Mater-cooled	(S-0394)	208244G01	1	1	1	1	1	
3	Hater Regulator	WV11-33RHD	415425-01	1	1	1	1	1	
4	Drier	DYN-2-HD-1	418498-01	1	1	1	1	1	
5	Strap	G.S	425280-01	1	1	1	1	1	
6	Pipe (A) - High Side	Copper	425669-01	1	1	1	1	1	
7	-	-	-	-	-	-	-	-	
8	Pipe (C) - High Side	Copper	425670-01	1	1	1	1	1	
9	-	-	-	-	-	-	-	-	
10	-	-	-	-	-	-	-	-	
11	Tee	Copper	420041-02	1	1	1	1	1	
12	Tee	Copper	416263-01	1	1	1	1	1	
13	Pipe (A) - Oil Cooler	Copper	425671-01	1	1	1	1	1	
14	Pipe (B) - Oil Cooler	Copper	425672-01	1	1	1	1	1	
15	Pipe (F) - High Side	Copper	425673-01	1	-	-	-	-	
16	Tee - Fusible Plug	YWP-251-HD	421832-01	1	-	-	-	-	
17	Fusible Plug	FUP-1105H12	4U0010-01	1	-	-	-	-	
18	Pipe - Low Side	Copper	316028G01	1	1	1	1	1	
19	Tie	CV-100	7920-0002	2	2	2	2	2	
20	Expansion Valve	HYP2-5HD4	411518-04	1	1	1	1	1	
21	Cover (A) - Expansion Valve	PE Foam	315741-01	1	1	1	1	1	
22	Cover (B) - Expansion Valve	PE Foam	315741-02	1	1	1	1	1	
23	Pipe (G) - High Side	Copper	425286-01	1	1	1	1	1	
24	Process Tube	Copper	425674-01	1	1	1	1	1	
25	Access Valve	TCJ-2F15-HD	417366-01	1	1	1	1	1	
26	Clamp	PA	402245-01	1	1	1	1	1	
27	Pressure Switch	SNS-2C130YQ3	425679-01	1	1	1	1	1	
28	Pipe (A)	Copper	425675-01	1	1	1	1	1	
29	Pipe (B)	Copper	425676-01	1	1	1	1	1	

MODEL		TITLE		REQ'D NUMBER				
F-1101AWU		C. REFRIGERATION UNIT						
INDEX NO.	DESCRIPTION	MATERIAL OR MODEL NUMBER	PART NUMBER	REQ'D NUMBER				
				H-0	J-1	J-2		
H	FITTING (U) ASSEMBLY	(S-0382)	314347A01	2	2	2		
1	Compressor	KL100TD-3	2U0043-01	1	1	1		
2	Condenser - Water-cooled	(S-0394)	208244G01	1	1	1		
3	Water Regulator	WV II-33RHD	415425-01	1	1	1		
4	Drier	DYN-2-HD-1	418498-01	1	1	-		
		KC-6749	427061-01			1		
5	Strap	G.S	425280-01	1	1	-		
			425280-02			1		
6	Pipe (A) - High Side	Copper	425669-01	1	1	1		
7	-	-	-	-				
8	Pipe (C) - High Side	Copper	425670-01	1	1	1		
9	-	-	-	-				
10	-	-	-	-				
11	Tee	Copper	420041-02	1	1	1		
12	Tee	Copper	416263-01	1	1	1		
13	Pipe (A) - Oil Cooler	Copper	425671-01	1	1	1		
14	Pipe (B) - Oil Cooler	Copper	425672-01	1	1	1		
15	-	-	-	-				
16	-	-	-	-				
17	-	-	-	-				
18	Pipe - Low Side	Copper	316028G01	1	1	1		
19	Tie	CV-100	7920-0002	2	2	2		
20	Expansion Valve	HYP2-5HD4	411518-04					
		HYP2-5HD9	411518-07	①	1	1		
21	Cover (A) - Expansion Valve	PE Foam	315741-01	1	1	1		
22	Cover (B) - Expansion Valve	PE Foam	315741-02	1	1	1		
23	Pipe (G) - High Side	Copper	425286-01	1	1	-		
	Pipe (J) - High Side	Copper	425286-02			1		
24	Process Tube	Copper	425674-01	1	1	1		
25	Access Valve	TCJ-2F15-HD	417366-01	1	1	1		
26	Clamp	PA	402245-01	1	1	1		
27	Pressure Switch	SNS-2C130YQ3	425679-01	1	1	1		
28	Pipe (A)	Copper	425675-01	1	1	1		
29	Pipe (B)	Copper	425676-01	1	1	1		

MODEL		TITLE						
F-1101AWU		C. REFRIGERATION UNIT						
INDEX NO.	DESCRIPTION	MATERIAL OR MODEL NUMBER	PART NUMBER	REQ'D NUMBER				
				E-1	F-1	F-2	G-1	G-2
30	Pipe (C)	Copper	425677-01	1	1	1	1	1
31	-	-	-	-	-	-	-	-
32	Strap	G.S	425668-01	1	1	1	1	1
33	Overload	MSH16AIU	429382-01	1	1	1	1	1

MODEL		TITLE						
F-1101AWU		C. REFRIGERATION UNIT						
INDEX NO.	DESCRIPTION	MATERIAL OR MODEL NUMBER	PART NUMBER	REQ'D NUMBER				
				H-0	J-1			
30	Pipe (C)	Copper	425677-01	1	1			
31	-	-	-	-				
32	Strap	G.S	425668-01	1	1			
33	Overload	MSH16AIU	429382-01	1	1			





MODEL		TITLE						
F-1101AWU		D. MATER CIRCUIT ASSEMBLY						
INDEX NO.	DESCRIPTION	MATERIAL OR MODEL NUMBER	PART NUMBER	REQ'D NUMBER				
				E-1	F-1	F-2	G-1	G-2
J	FITTING (K) ASSEMBLY	(S-0331)	310978A01	1	1	1	1	1
1	Pipe - Water Supply	S.S	425287G01	1	1	1	1	1
2	Packing	NBR	413854-03	1	1	1	1	1
3	Water Valve	J246-086	3U0065-01	1	1	1	1	1
4	Bracket - Hater Valve	G.S	425288-01	1	1	1	1	1
5	Bracket - Reservoir	G.S	315744-01	1	1	1	1	1
6	Reservoir	ABS	208125-01	1	1	1	1	1
7	Separator - Reservoir	ABS	423538-02	1	1	1	1	1
8	Collar	S.S	423416-01	1	1	1	1	1
9	Cover - Reservoir	ABS	208126-01	1	1	1	1	1
10	Float Switch	FFS-536B6IB-21	417220-01	1	1	1	1	1
11	Hose - Water Supply	EVA	425289-01	1	1	1	1	1
12	Cover - Reservoir Inlet	SI.R	415094-01	1	1	1	1	1
13	Hose - Water Supply	PP Polymer	422922-01	1	-			
		EPDM	428615-05		1	1	1	1
14	Pipe - Drain	S.S	425292G01	1	1	1	1	1
15	Cap - Drain	Brass	425293-01	1	1	1	1	1
16	Packing - Drain	Sy.R	425294-01	1	1	1	1	1
17	Clamp	MH-30N	421642-04	2	2	2	2	2
18	Clamp	MH-44N	421642-07	1	1	1	1	1
19	Clamp	MH-50N	421642-08	1	-			
		SK-183	426148-07		1	1	1	1
20	Clamp	MH-56N	421642-09	4	3	3	3	3
21	-	-	-	-				
22	2-Pin Connector	J24032422	414358-01	1	-			
23	Clamp	SK-250	426148-08		1	1	1	1

MODEL		TITLE						
F-1101AWU		D. WATER CIRCUIT ASSEMBLY						
INDEX NO.	DESCRIPTION	MATERIAL OR MODEL NUMBER	PART NUMBER	REQ'D NUMBER				
				H-0	J-1	J-2		
J	FITTING (K) ASSEMBLY	(S-0331)	310978A01	1	1	1		
1	Pipe - Hater Supply	S.S	425287G01	1	1	1		
2	Packing	NBR	413854-03	1	1	1		
3	Hater Valve	J246-086	3U0065-01	1	1	1		
4	Bracket - Hater Valve	G.S	425288-01	1	1	1		
5	Bracket - Reservoir	G.S	315744-01	1	1	1		
6	Reservoir	ABS	208125-01	1	1	1		
7	Separator - Reservoir	ABS	423538-02	1	1	1		
8	Collar	S.S	423416-01	1	1	1		
9	Cover - Reservoir	ABS	208126-01	1	1	1		
10	Float Switch	FFS-536B6IB-21	417220-01	1	1			
		TW-1221-101	435490-01				①	
11	Hose - Hater Supply	EVA	425289-01	1	1	1		
12	Cover - Reservoir Inlet	SI.R	415094-01	1	1	1		
13	Hose - Hater Supply	EPDM	428615-05	1	1	1		
14	Pipe - Drain	S.S	425292G01	1	1	1		
15	Cap - Drain	Brass	425293-01	1	1	1		
16	Packing - Drain	Sy.R	425294-01	1	1	1		
17	Clamp	MH-30N	421642-04	2	2	2		
18	Clamp	MH-44N	421642-07	1	1	1		
19	Clamp	SK-183	426148-07	1	1	1		
20	Clamp	MH-56N	421642-09	3	3	3		
21	-	-	-	-				
22	-	-	-	-				
23	Clamp	SK-250	426148-08	1	1	1		

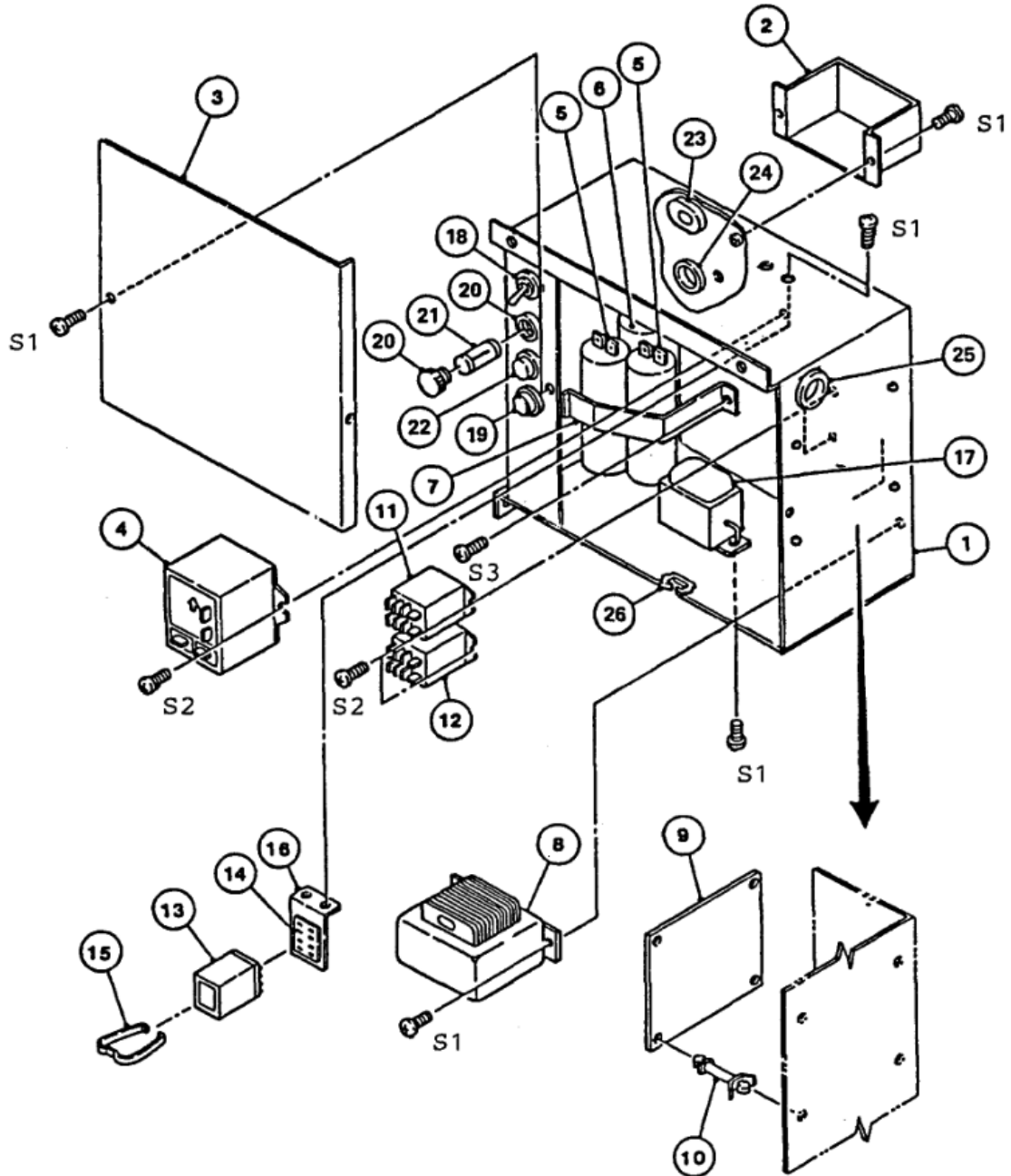

FASTENER

- S1 - TRUSS HEAD MACHINE SCREW, M4x6
- S2 - TRUSS HEAD TAPPING SCREW, M3x8
- S3 - TRUSS HEAD MACHINE SCREW, M4x8

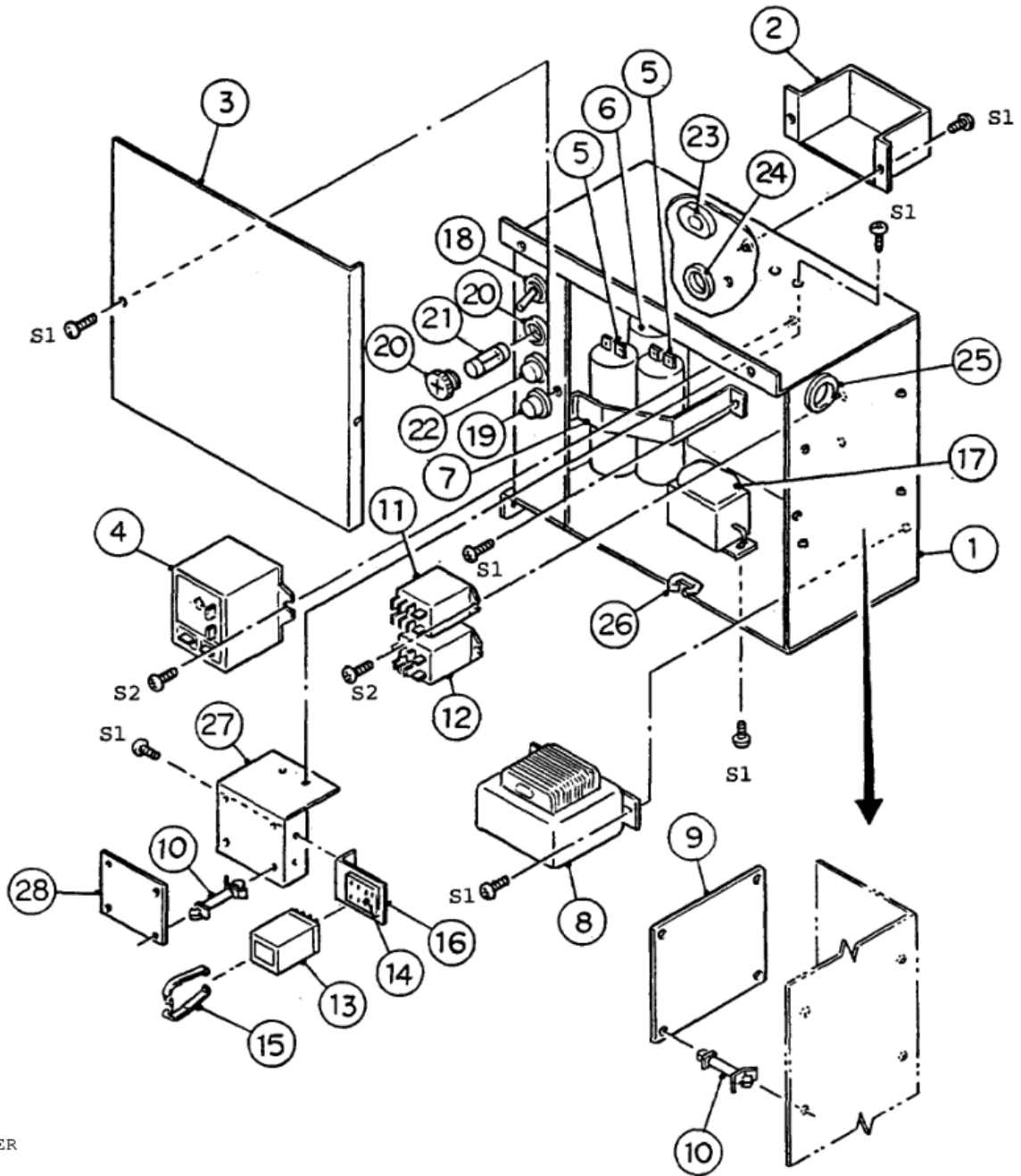

FASTENER

- S1 - TRUSS HEAD MACHINE SCREW, M4x8
- S2 - TRUSS HEAD TAPPING SCREW, M3x8

MODEL F-1101AWU		TITLE E. CONTROL BOX ASSEMBLY						
INDEX NO.	DESCRIPTION	MATERIAL OR MODEL NUMBER	PART NUMBER	REQ'D NUMBER				
				E-1	F-1	F-2	G-1	G-2
1	Control Box	G.S	315746G05	1	1	1	1	1
2	Cover - Connector	G.S	425302-01	1	1	1	1	1
3	Cover - Control Box	G.S	425301-01	1	1	1	1	1
4	Starter	FST-275B	422619-01	1	1	1	1	1
5	Start Capacitor	MS180F100(J)-R	3U0054-01	2	2	2	2	2
6	Run Capacitor	PMT-40250(P)	3U0058-01	1	1	-		
7	Strap - Capacitor	PMT-SH	431200-01			1	1	1
		G.S	425299-01	1	1	-		
8	Transformer		431394-01			1	1	1
		TR5268	2U0041-01	1	1	1	1	1
9	Timer Board	424292	424292-01	1	1	1	1	1
10	Board Support	KGLS-6S	414929-01	4	4	4	4	4
11	Relay	LY1F-US	422608-02	1	1	1	1	1
12	Relay	LY2ZFAG-US	427318-01	1	1	1	1	1
13	Keep Relay	MY2K-HO	418524-03	1	1	1	1	1
14	Socket - Relay	PY-14	408328-02	1	1	1	1	1
15	Clamp - Relay	PYC-P	411353-01	1	1	1	1	1
16	Bracket - Relay	G.S	425300-01	1	1	1	1	1
17	Thermostat	A22-2504	425202-01	1	1	1	1	1
18	Toggle Switch	S-421	3U0039-01	1	1	1	1	1
19	Push Button Switch	SB-4011N/0T3959	420466-01	1	1	1	1	1
20	Fuse Holder	FH032	424288-01	1	1	1	1	1
21	Fuse	FGA0-2	420468-03	1	1	1	1	1
22	Overload - Gear Motor	M58xBIA4A-2	425201-01	1	1	1	1	1
23	Bushing	SR-4K-4	420472-01	1	1	1	1	1
24	Bushing	SB-625-8	420470-01	1	1	1	1	1
25	Bushing	SB-750-10	420470-05	1	1	1	1	1
26	Edge Saddle	EDS-1	421552-01	1	1	1	1	1

MODEL		TITLE						
P-1101AWU		E. CONTROL BOX ASSEMBLY						
INDEX NO.	DESCRIPTION	MATERIAL OR MODEL NUMBER	PART NUMBER	REQ'D NUMBER				
				H-0	J-1			
1	Control Box	G.S	315746G05	1	1			
2	Cover - Connector	G.S	425302-01	1	1			
3	Cover - Control Box	G.S	425301-01	1	1			
4	Starter	FST-275B	422619-01	1	1			
5	Start Capacitor	MS180F100(J)-R	3U0054-01	2	2			
6	Run Capacitor	PMT-SH	431200-01	1	1			
7	Strap - Capacitor	G.S	431394-01	1	1			
8	Transformer	TR5268	2U0041-01	1	1			
9	Timer Board	424292	424292-01	1	1			
10	Board Support	KGLS-6S	414929-01	4	4			
11	Relay	LY1F	418271-04	1	1			
12	Relay	LY2ZF	406132-06	1	1			
13	Keep Relay	MY2K-H0	418524-03	1	1			
14	Socket - Relay	PY-14	408328-02	1	1			
15	Clamp - Relay	PYC-P	411353-01	1	1			
16	Bracket - Relay	G.S	425300-01	1	1			
17	Thermostat	A22-2504	425202-01	1	-			
		A10-9756	420465-01		1			
18	Toggle Switch	S-421	3U0039-01	1	1			
19	Push Button Switch	SB-4011N/0T3959	420466-01	1	1			
20	Fuse Holder	FH032	424288-01	1	1			
21	Fuse	FGA0-2	420468-03	1	1			
22	Overload - Gear Motor	W58xBIA4A-2	425201-01	1	1			
23	Bushing	SR-4K-4	420472-01	1	1			
24	Bushing	SB-625-8	420470-01	1	1			
25	Bushing	SB-750-10	420470-05	1	1			
26	Edge Saddle	EDS-1	421552-01	1	1			
27	Beeper Bracket	G.S	323312-01		1			
28	Beeper	-	435937-01		1			

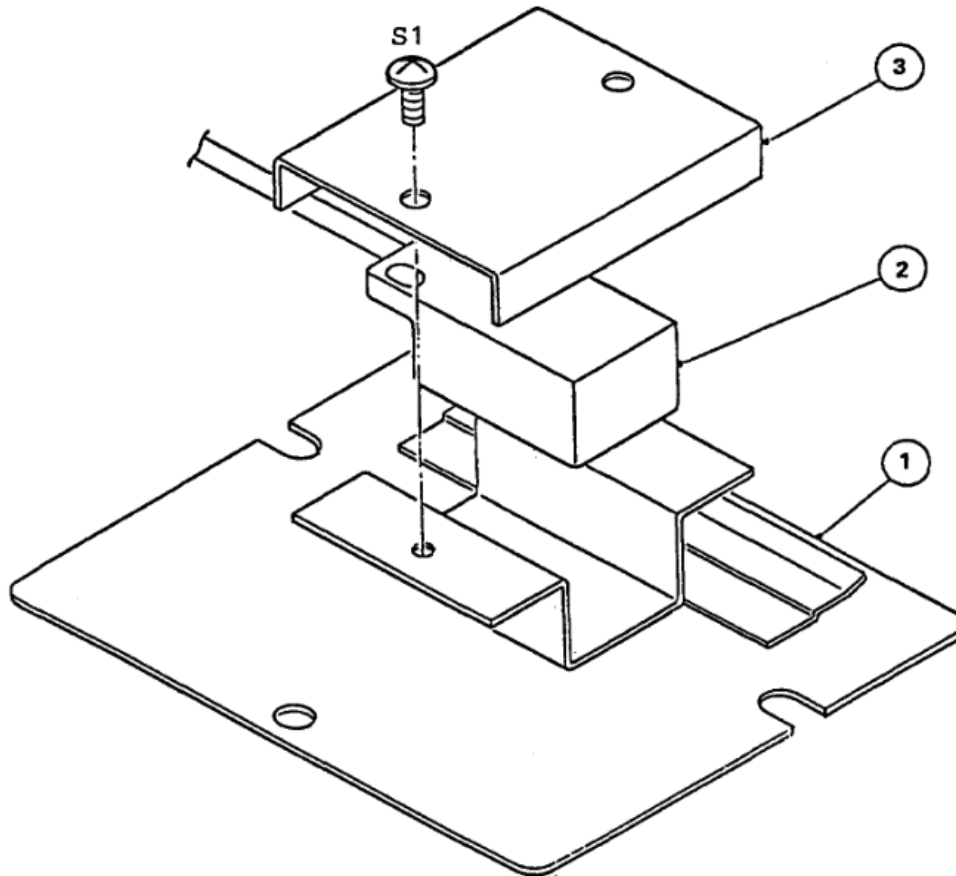

FASTENER S1 - TRUSS HEAD MACHINE SCREW, STAINLESS. M4x6

MODEL		TITLE						
F-1101AWU		F. BIN SWITCH ASSEMBLY						
INDEX NO.	DESCRIPTION	MATERIAL OR MODEL NUMBER	PART NUMBER	REQ'D NUMBER				
				E-1	F-1	F-2	G-1	G-2
1	Bracket - Switch	S.S	317648G01	1	1	1	1	1
2	Proximity Switch - Bin Control	RS-601	427223-01	1	1	1	1	1
3	Bracket - Proximity Switch	S.S	427158-01	1	1	1	1	1

MODEL		TITLE						
F-1101AWU		F. BIN SWITCH ASSEMBLY						
INDEX NO.	DESCRIPTION	MATERIAL OR MODEL NUMBER	PART NUMBER	REQ'D NUMBER				
				H-0	J-1			
1	Bracket - Switch	S.S	317648G01	1	1			
2	Proximity Switch - Bin Control	RS-601	427223-01	1	1			
3	Bracket - Proximity Switch	S.S	427158-01	1	1			

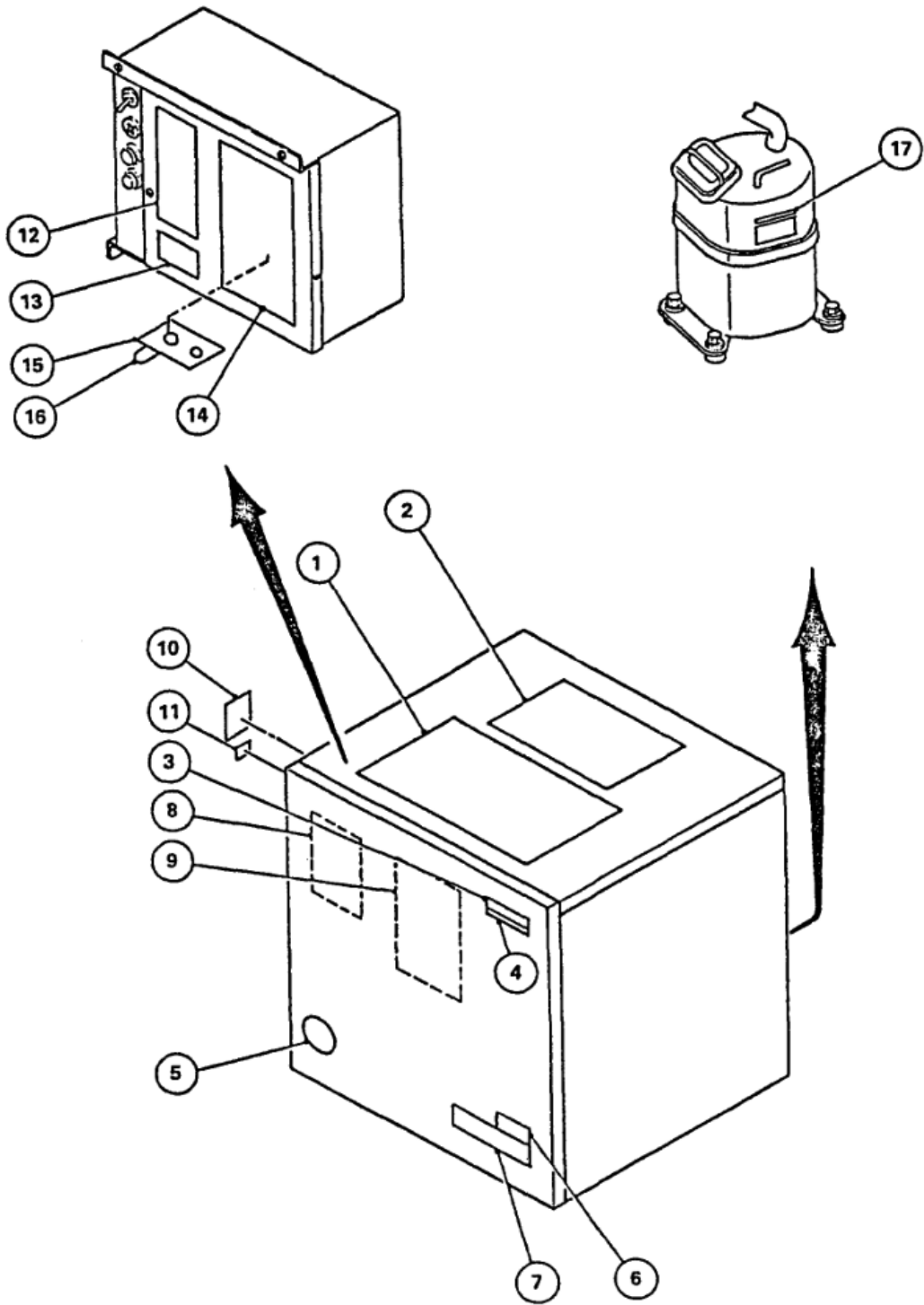

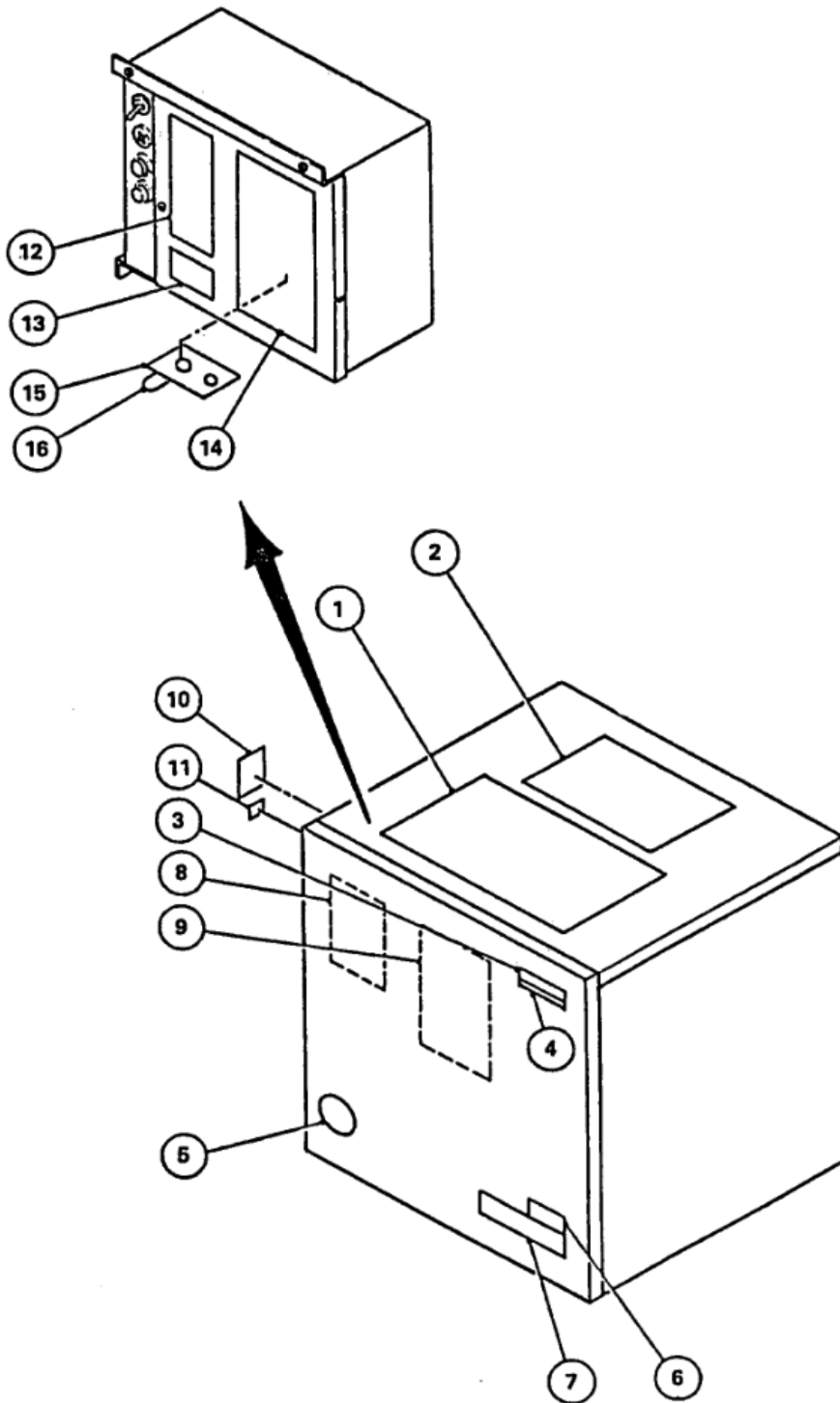

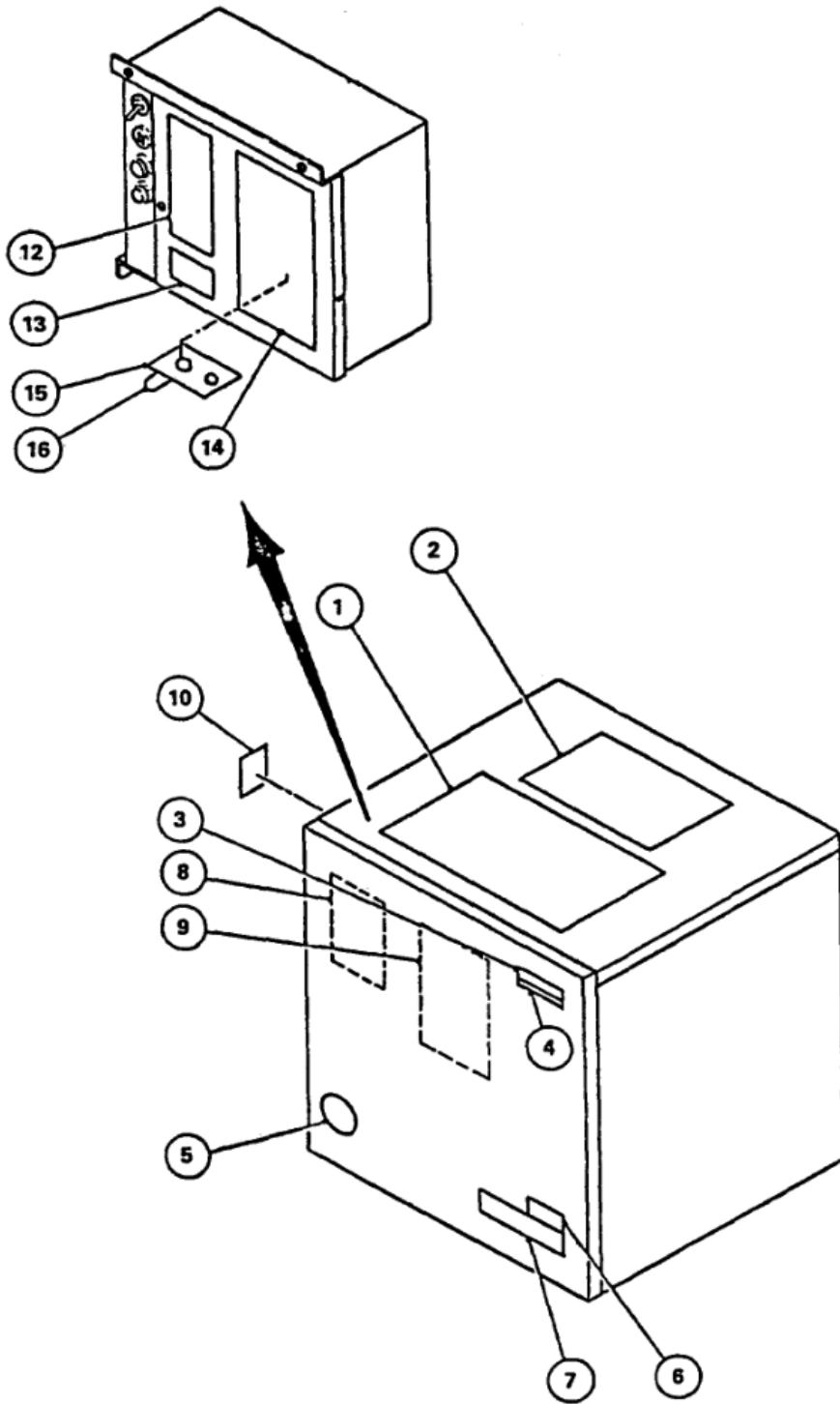

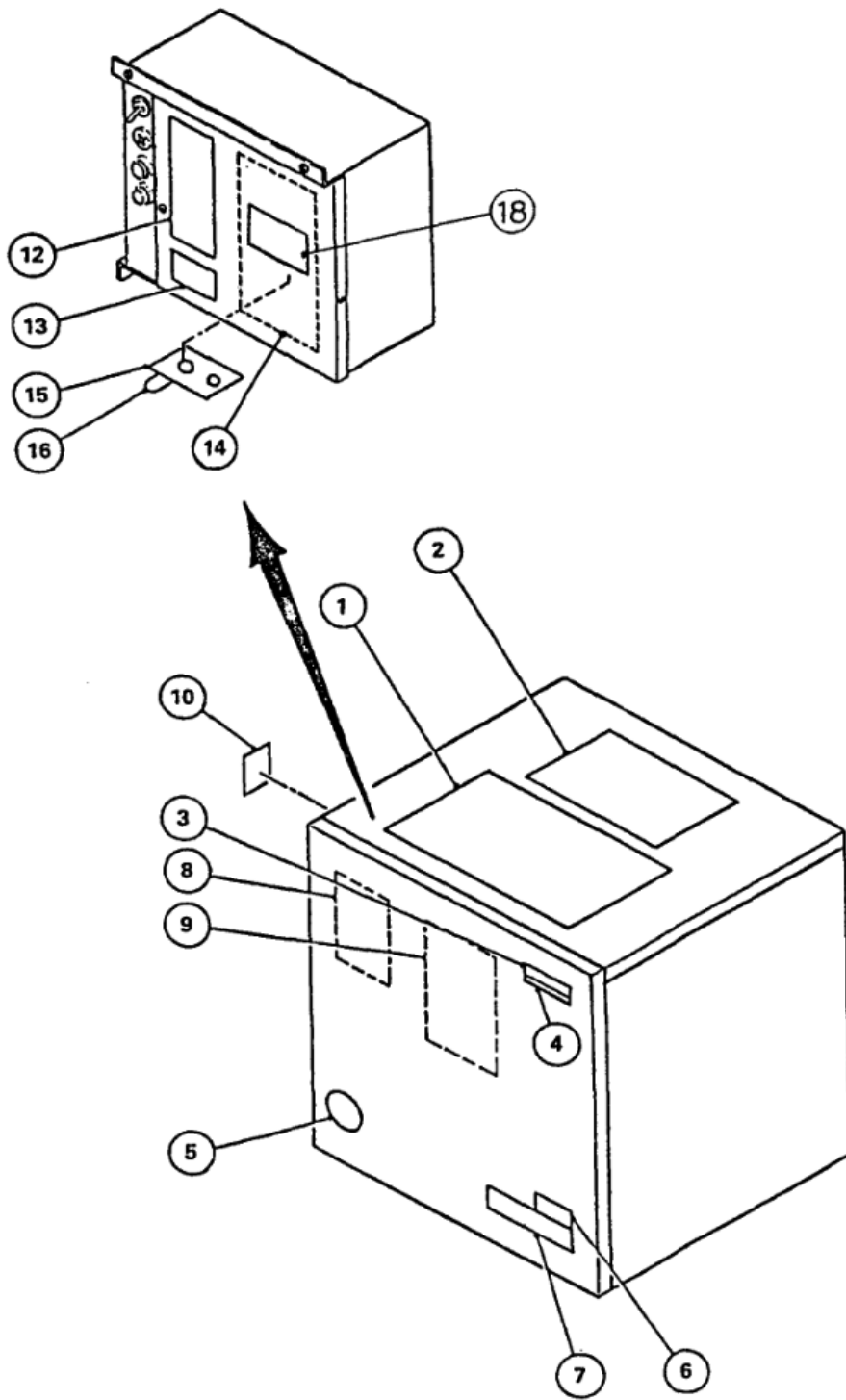

MODEL		TITLE						
F-1101AWU		G. LABEL LOCATION						
INDEX NO.	DESCRIPTION	MATERIAL OR MODEL NUMBER	PART NUMBER	REQ'D NUMBER				
				E-1	F-1	F-2	G-1	G-2
1	Instruction Sheet - Inst. Ope.	Paper	208144-01	1	1	1	1	1
2	Instruction Sheet - Bin Inst.	Paper	208145-01	1	1	1	1	1
3	Emblem (L) - HOSHIZAKI	ABS	418634G01	1	1	1	1	1
4	Label - Model Number	PETP Film	425327-**	1	1	1	1	1
5	Label - Penguin	PETP Film	410994-01	1	1	1	1	1
6	Label - Warning	PVC Film	425323-01	1	1	1	1	1
7	Label - Operation, Spout Cont.	PETP Film	425325-01	1	1	1	1	1
8	Label - Operation	PVC Film	315758-01	1	1	1	1	1
9	Label - Cleaning	PVC Film	208146-01	1	1	1	1	1
10	Nameplate	PES Film	211624-01					①
			428992-01	1	1	1	1	-
			432828-01					1
11	Label - NSF	-	423170-01	1	1	1	1	-
12	Label - Control Box	PETP Film	425329-01	1	1	1	1	1
13	Label - Danger	PVC Film	425322-01	1	1	1	1	1
14	Label - Wiring Diagram	PVC Film	317654-01	1	1	1	1	1
15	Label - Spout Control	PETP Film	428016-01	1	1	1	1	1
16	Label - Factory Adjusted	PETP Film	419404-01	1	1	1	1	1
17	Label - Thermally Protected	PES Film	427316-01	1	1	1	-	

\*\* is as same as the Auxiliary Code. 17

MODEL		TITLE						
F-1101AWU		G. LABEL LOCATION						
INDEX NO.	DESCRIPTION	MATERIAL OR MODEL NUMBER	PART NUMBER	REQ'D NUMBER				
				H-0	J-1			
1	Instruction Sheet - Inst. Ope.	Paper	208144-01	1	1			
2	Instruction Sheet - Bin Inst.	Paper	208145-01	1	1			
3	Emblem (L) - HOSHIZAKI	ABS	418634G01	1	1			
4	Label - Model Number	PETP Film	425305-**	1	1			
5	Label - Penguin	PETP Film	410994-01	1	1			
6	Label - Warning	PVC Film	425323-01	1	1			
7	Label - Operation, Spout Cont.	PETP Film	425325-01	1	1			
8	Label - Operation	PVC Film	315758-01	1	1			
9	Label - Cleaning	PVC Film	211624-01	1	1			
10	Nameplate	PES Film	432828-01	1	1			
11	-	-	-	-				
12	Label - Control Box	PETP Film	425329-01	1	1			
13	Label - Danger	PVC Film	425322-01	1	1			
14	Label - Wiring Diagram	PVC Film	317654-01	1	-			
	Wiring Label		323348-01		1			
15	Label - Spout Control	PETP Film	428016-01	1	-			
	Label - Bin Thermostat		435984-01		1			
16	Label - Factory Adjusted	PETP Film	419404-01	1	1			
17	-	-	-	-				
18	Warning Label	PVC Film	435955-01		1			

\*\* is as same as the Auxiliary Code.

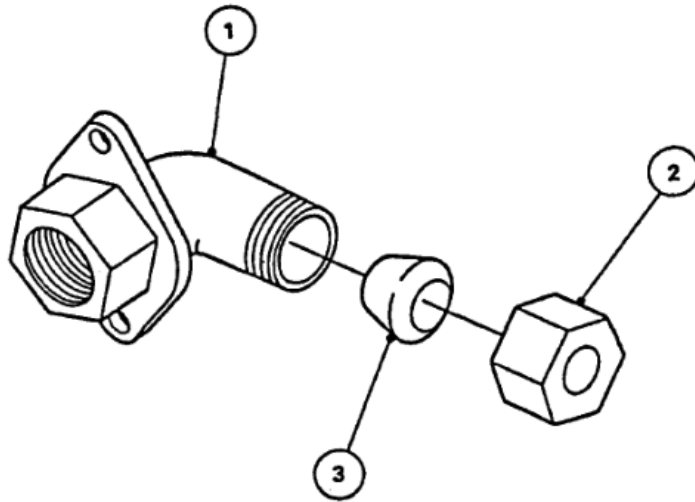

MODEL		TITLE						
F-1101AWU		H. FITTING (U) ASSEMBLY						
INDEX NO.	DESCRIPTION	MATERIAL OR MODEL NUMBER	PART NUMBER	REQ'D NUMBER				
				E-1	F-1	F-2	G-1	G-2
1	Fitting (M)	Brass Casting	<a href="#">310980-01</a>	1	1	1	1	1
2	Nut (A)	Brass	<a href="#">415713-01</a>	1	1	1	1	1
3	Packing (A)	Sy.R	<a href="#">415715-01</a>	1	1	1	1	1

MODEL		TITLE						
F-1101AWU		H. FITTING (U) ASSEMBLY						
INDEX NO.	DESCRIPTION	MATERIAL OR MODEL NUMBER	PART NUMBER	REQ'D NUMBER				
				H-0	J-1			
1	Fitting (M)	Brass Casting	<a href="#">310980-01</a>	1	1			
2	Nut (A)	Brass	<a href="#">415713-01</a>	1	1			
3	Packing (A)	Sy.R	<a href="#">415715-01</a>	1	1			

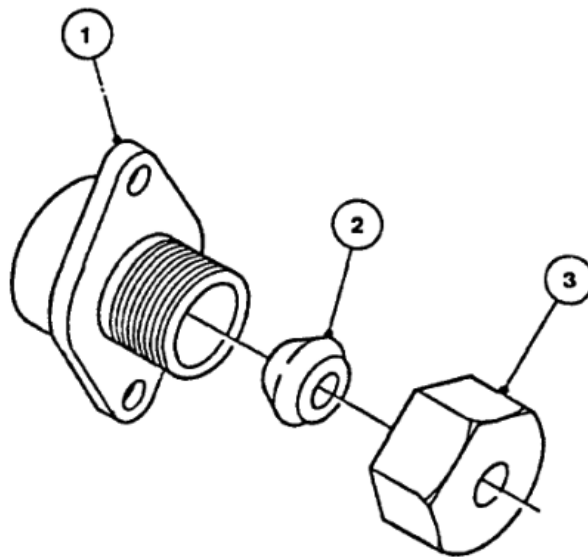

MODEL		TITLE						
F-1101AWU		J. FITTING(K) ASSEMBLY						
INDEX NO.	DESCRIPTION	MATERIAL OR MODEL NUMBER	PART NUMBER	REQ'D NUMBER				
				E-1	F-1	F-2	G-1	G-2
1	Fitting (K)	Brass Casting	<a href="#">310978-01</a>	1	1	1	1	1
2	Packing (C)	Sy.R	<a href="#">415715-02</a>	1	1	1	1	1
3	Nut (B)	Brass	<a href="#">415713-02</a>	1	1	1	1	1

MODEL		TITLE						
F-1101AWU		J. FITTING (K) ASSEMBLY						
INDEX NO.	DESCRIPTION	MATERIAL OR MODEL NUMBER	PART NUMBER	REQ'D NUMBER				
				H-0	J-1			
1	Pitting (K)	Brass Casting	<a href="#">310978-01</a>	1	1			
2	Packing (C)	Sy.R	<a href="#">415715-02</a>	1	1			
3	Nut (B)	Brass	<a href="#">415713-02</a>	1	1			

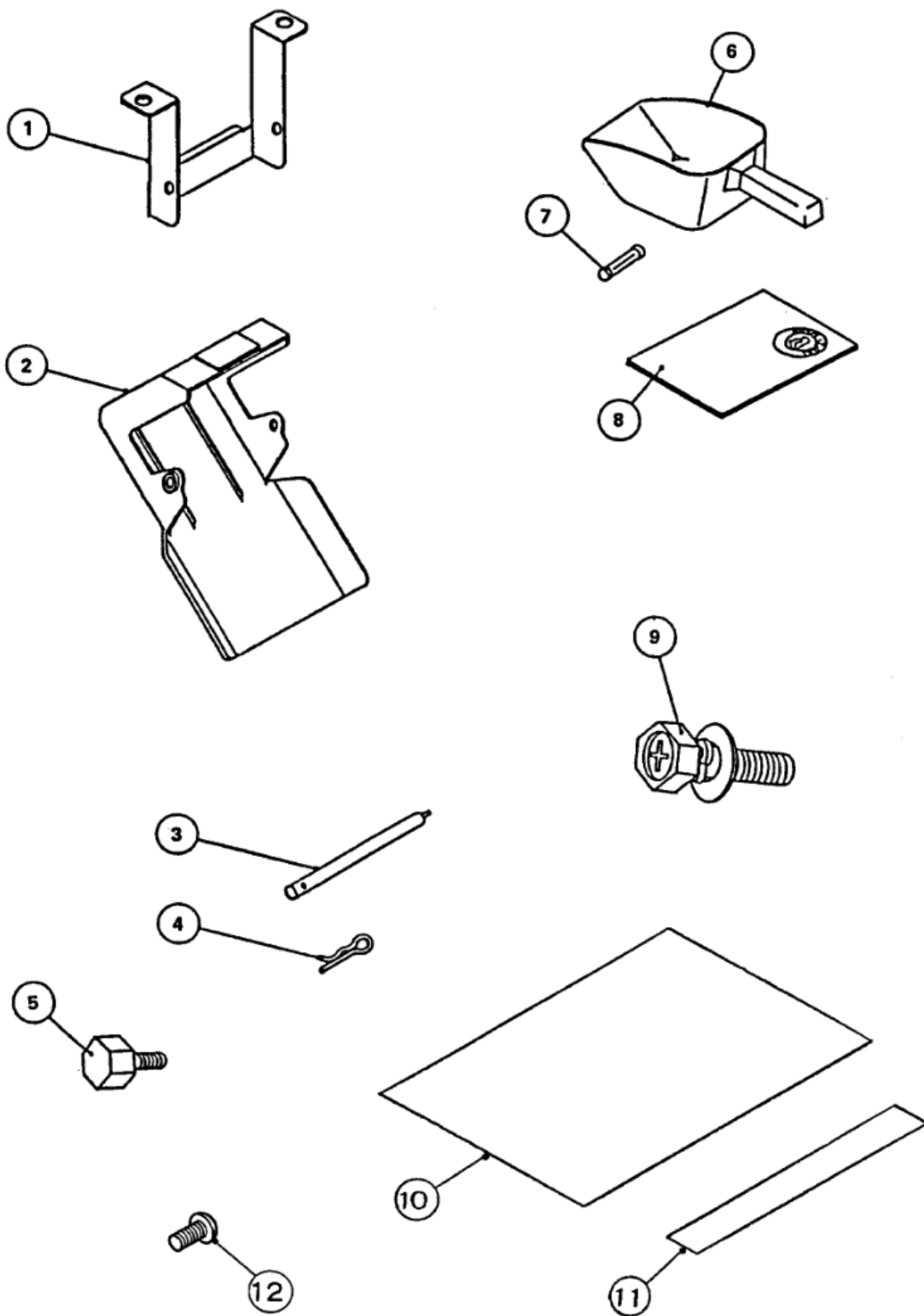

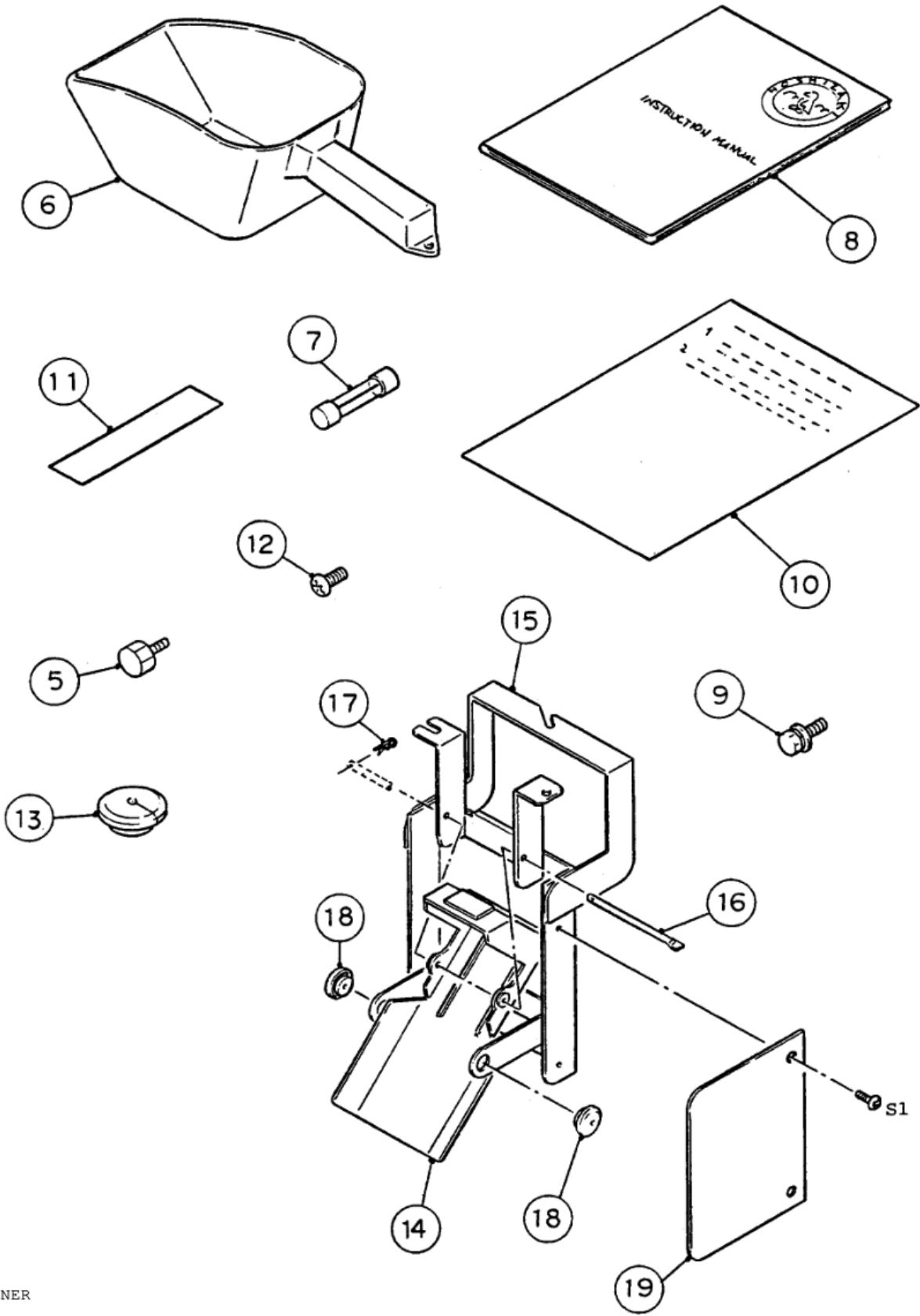

FASTENER

S1 - TRUSS HEAD MACHINE SCREW, STAINLESS, M4x8

MODEL		TITLE						
F-1101AWU		K. ACCESSORIES						
INDEX NO.	DESCRIPTION	MATERIAL OR MODEL NUMBER	PART NUMBER	REQ'D NUMBER				
				E-1	F-1	F-2	G-1	G-2
1	Bracket - Actuator	S.S	428003-01	1	1	1	1	1
2	Actuator - Switch	ABS	209168G01	1	1	1	1	1
3	Shaft	S.S	412337-03	1	1	1	1	1
4	Snap Pin	S.S, SSP-4	715S-0004	1	1	1	1	1
5	Thumbscrew	S.S, ABS	415949G04	3	3	3	3	3
6	Scoop	PE	208185-01	1	1	1	1	1
7	Fuse	FGA0-2, 1A	420468-03	1	1	1	1	1
8	Instruction Manual	Paper	9021G-18A	1	-			
			91U2AA10A		1	1	1	
			91U2AA10B					①
9	Bolt And Hasher Assy SW	S.S, M8x16	-	2	2	2	2	2
10	Instruction Sheet - Actuator	Paper	317651-01	1	1	1	1	1
11	Instruction Sheet - Fastener	Paper	427122-01	1	1	1	1	1
12	Truss Head Machine Screw	S.S, M4x30	-	2	2	2	2	2

MODEL		TITLE						
F-1101AWU		K. ACCESSORIES						
INDEX NO.	DESCRIPTION	MATERIAL OR MODEL NUMBER	PART NUMBER	REQ'D NUMBER				
				H-0	J-1			
1	Bracket - Actuator	S.S	428003-01	1	-			
2	Actuator - Switch	ABS	209168G01	1	-			
3	Shaft	S.S	412337-03	1	-			
4	Snap Pin	S.S, SSP-4	715S-0004	1	-			
5	Thumbscrew	S.S, ABS	415949G04	3	3			
6	Scoop	PE	208185-01	1	1			
7	Fuse	FGA0-2, 1A	420468-03	1	1			
8	Instruction Manual	Paper	91U2AA10B	1	-			
			91U2AA10C		1			
9	Bolt And Washer Assy SW	S.S, M8x16	-	2	2			
10	Instruction Sheet - Actuator	Paper	317651-01	1	-			
	Instruction Sheet - Bin Control		323351-01		1			
11	Instruction Sheet - Fastener	Paper	427122-01	1	1			
12	Truss Head Machine Screw	S.S, M4x30	-	2	2			
13	Bushing - Cappillary Tube	EP Rubber	425307-01		1			
14	Actuator - Switch		209168G01		1			
15	Bin Control Bracket	Bin Control	323306G01		1			
16	Shaft	Assembly	412337-03		1			
17	Snap Pin	(323318A01)	715S-0004		1			
18	Bushing - Cappillary Tube		425307-01		2			
19	Paddle Cover (B)		435869-01		1			

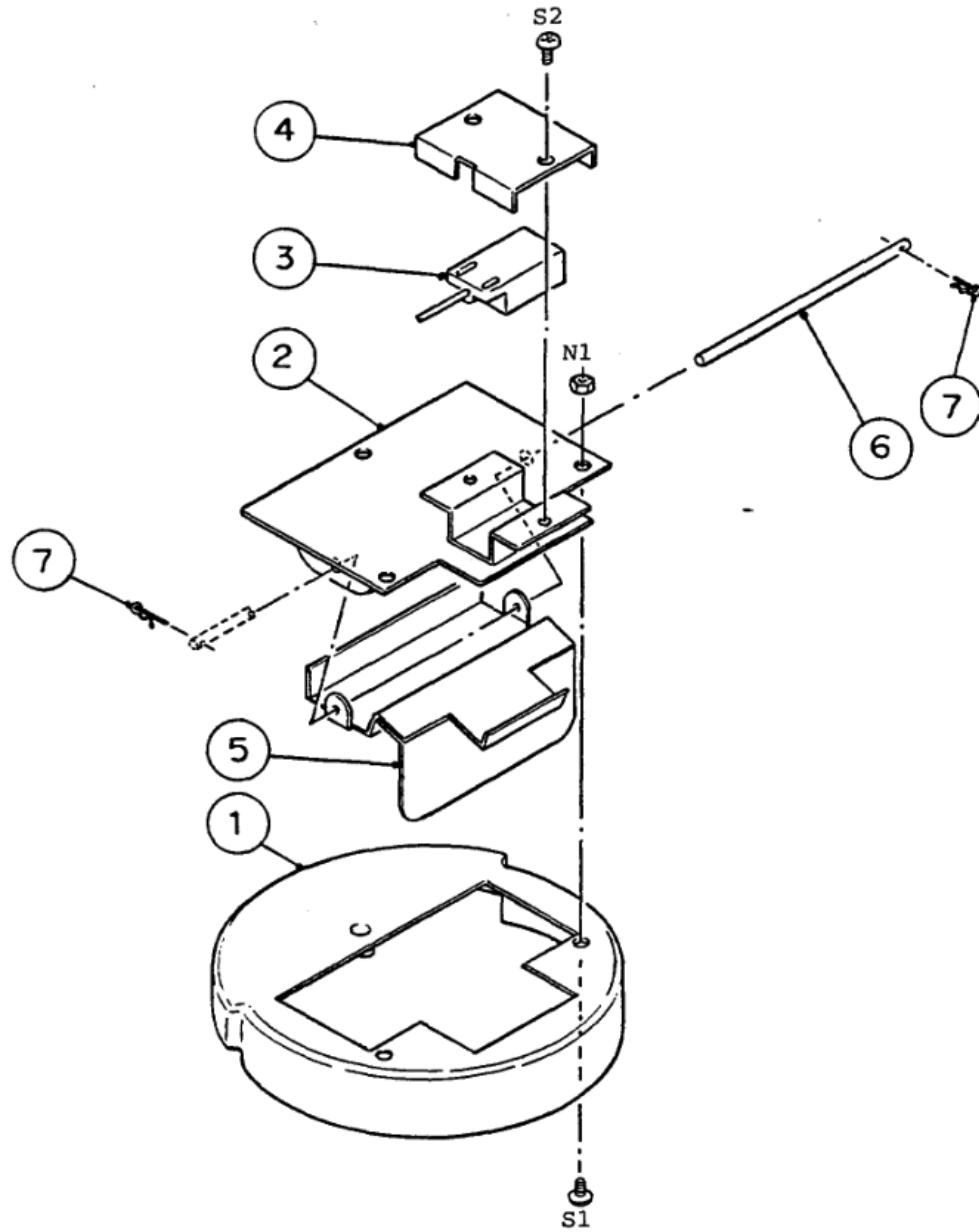

FASTENER

- S1 - TRUSS HEAD MACHINE SCREW, STAINLESS, M4x8
- S2 - TRUSS HEAD MACHINE SCREW, STAINLESS, M4x6
- N1 - U Nut. STAINLESS, M4

MODEL		TITLE					
F-1101AWU		L. SPOUT CONTROL ASSEMBLY					
INDEX NO.	DESCRIPTION	MATERIAL OR MODEL NUMBER	PART NUMBER	REQ'D NUMBER			
				J-1			
1	Cover - Chute	ABS	213116G01	1			
2	Spout Cover	S.S	323307G01	1			
3	Proximity Switch	RS-601	427223-01	1			
4	Bracket - Proximity Switch	S.S	427158-01	1			
5	Paddle	S.S	323310G01	1			
6	Axle	S.S	435873-01	1			
7	Snap Pin	S.S, SSP-4	715S-0004	2			