



HOSHIZAKI

Parts List

Modular Flaker

Models

F-330BAJ(-C)



hoshizakiamerica.com

Number: 71371
Issued: 7-5-2016
Revised: 12-9-2019

CONTENTS

| | |
|--|----|
| Auxiliary Codes..... | 3 |
| Note About Ordering Parts | 3 |
| A. Main Assembly & Refrigeration Circuit | 4 |
| B. Icemaking Unit | 7 |
| C. Water Circuit..... | 9 |
| D. Control Box Assembly..... | 11 |
| E. Accessories & Labels | 12 |

Auxiliary Codes

F-330BAJ

| | |
|-----|---------------|
| E-0 | November 2015 |
| F-0 | August 2016 |
| F-1 | November 2016 |
| F-2 | December 2016 |
| G-0 | January 2017 |
| G-1 | April 2017 |
| G-2 | June 2017 |
| H-0 | January 2018 |
| H-1 | August 2018 |
| J-0 | January 2019 |
| J-1 | July 2019 |

F-330BAJ-C

| | |
|-----|---------------|
| E-0 | November 2015 |
| F-0 | July 2016 |
| F-1 | November 2016 |
| G-0 | January 2017 |
| G-1 | April 2017 |
| G-2 | June 2017 |
| H-0 | January 2018 |
| H-1 | August 2018 |
| J-0 | January 2019 |
| J-1 | July 2019 |

Auxiliary Code Breakdown

The auxiliary code is the first two characters in the serial number. The first character indicates the year. Years progress or regress in alphabetical order. The series runs from "A" through "V" and the letters "I" and "O" are skipped. The second character indicates significant part changes within a year. Base is "0" and this number advances for each change. In cases where there is a letter in parentheses, this designates the month. This is the last character in the serial number. The series runs from "(A)" through "(M)" and the letter "(I)" is skipped. This designation is only included when identifying a parts change within an auxiliary code.

Note About Ordering Parts

Most assemblies cannot be ordered as complete units; parts in the assemblies generally must be ordered separately.

A. Main Assembly & Refrigeration Circuit
F-330BAJ(-C)
1/2
E-0 to J-1

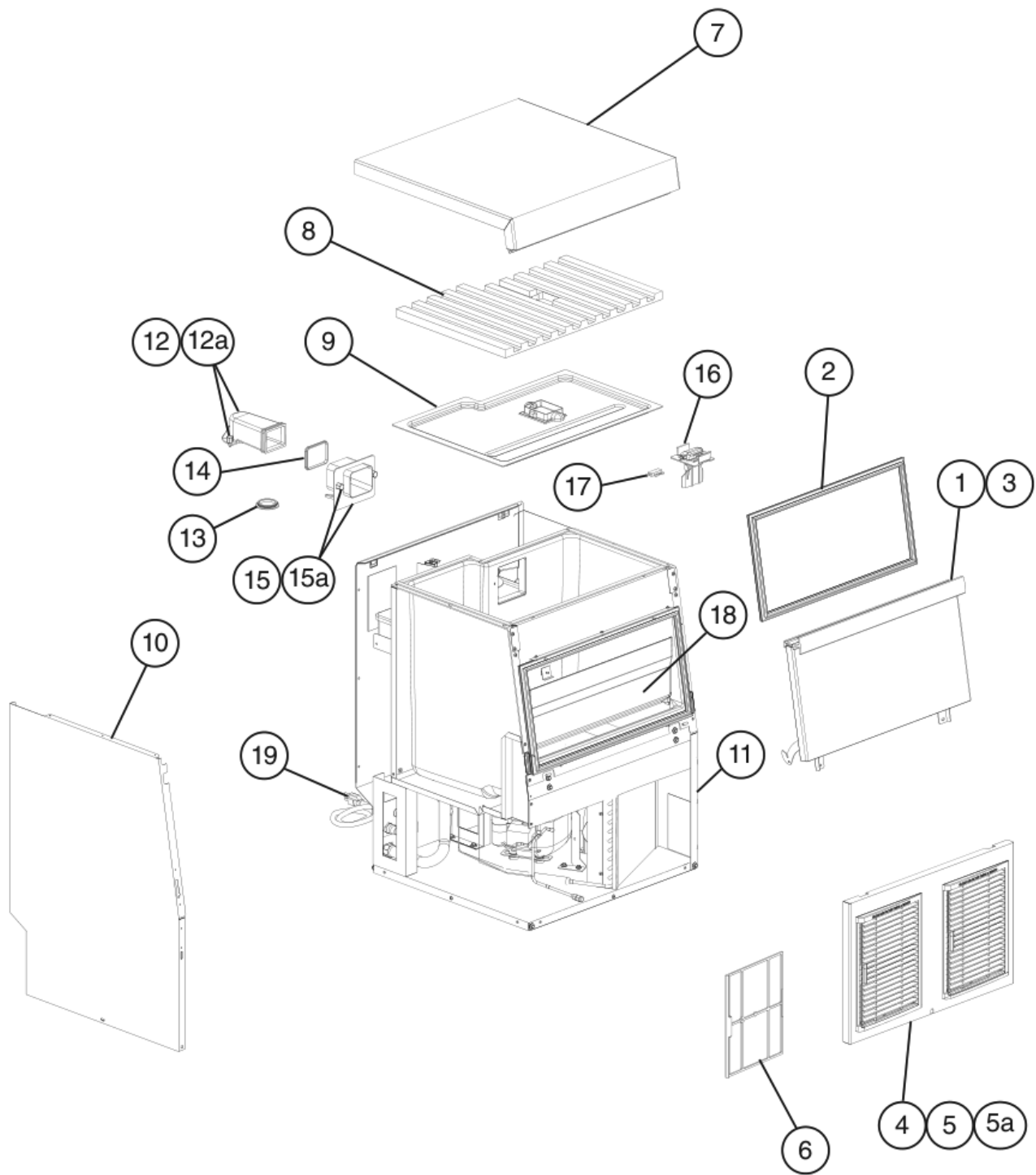

A. Main Assembly & Refrigeration Circuit
F-330BAJ(-C)
2/2
E-0 to J-1

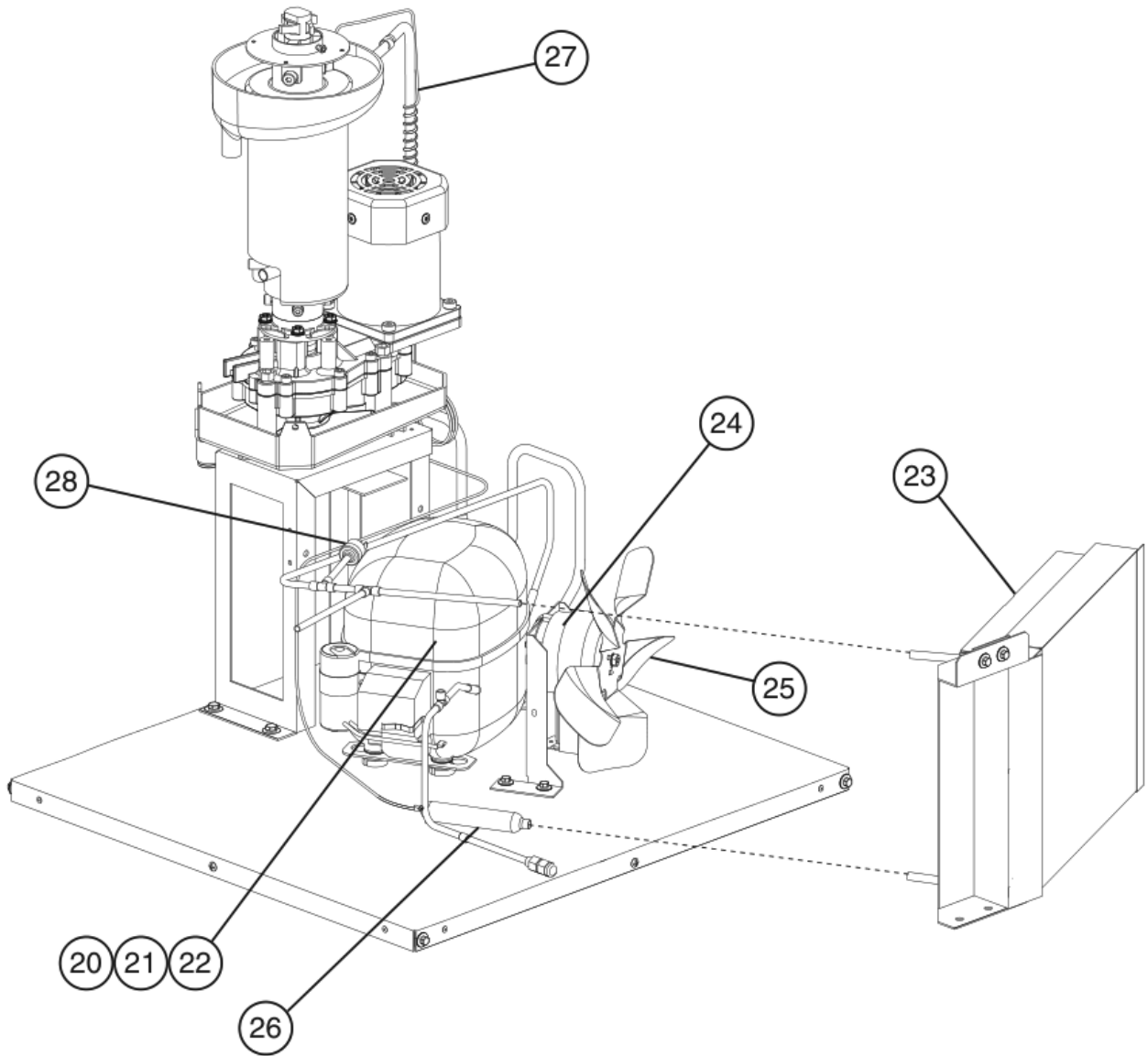

| Title: A. Main Assembly & Refrigeration Circuit Model: F-330BAJ(-C) | | | | | | | | | | | | |
|---|--|--------------------------|-------------|------------|-----------------|--|--|--|--|--|--|--|
| Index No. | Description | Material or Model Number | Part Number | E-0 to J-1 | Required Number | | | | | | | |
| | | | | | | | | | | | | |
| Main Assembly | | | | | | | | | | | | |
| 1 | Door | | 1A3657A01 | 1 | | | | | | | | |
| 2 | Door Gasket | | 2A6198-01 | 1 | | | | | | | | |
| 3 | Door Handle | | 2A3361-01 | 1 | | | | | | | | |
| 4 | Front Panel | | 1A1306-01 | 1 | | | | | | | | |
| 5 | Louver | | 1A0548-01 | 2 | | | | | | | | |
| 5a | Push Retainer | | 4A2414-01 | 6 | | | | | | | | |
| 6 | Air Filter | | 2A2063G01 | 1 | | | | | | | | |
| 7 | Top Panel | | 1A1307-01 | 1 | | | | | | | | |
| 8 | Top Insulation | | 1A1304-01 | 1 | | | | | | | | |
| 9 | Upper Panel | | 1A1303-01 | 1 | | | | | | | | |
| 10 | Left Side Panel | | 2A4079-01 | 1 | | | | | | | | |
| 11 | Right Side Panel | | 2A4080-01 | 1 | | | | | | | | |
| 12 | Spout (A) | | 208791-02 | 1 | | | | | | | | |
| 12a | Thumbscrew | | 415949G11 | 3 | | | | | | | | |
| 13 | Packing | | 427151-01 | 1 | | | | | | | | |
| 14 | Spout Packing (A) | | 453663-01 | 1 | | | | | | | | |
| 15 | Spout (B) | | 232654-03 | 1 | | | | | | | | |
| 15a | Thumbscrew | | 415949G11 | 2 | | | | | | | | |
| 16 | Bin Control Actuator | | 350301A02 | 1 | | | | | | | | |
| 17 | Bin Control Proximity Switch | | 453861-02 | 1 | | | | | | | | |
| 18 | Slope | | 2A4259-01 | 1 | | | | | | | | |
| 19 | Power Supply Cord | | 4A1773-01 | 1 | | | | | | | | |
| Refrigeration Circuit | | | | | | | | | | | | |
| 20 | Compressor | | 4A4185-01 | 1 | | | | | | | | |
| 21 | Start Relay (includes external protector) | | 4A2135-04 | 1 | | | | | | | | |
| 22 | Start Capacitor | 320MFD, 125VAC | 4A2134-04 | 1 | | | | | | | | |
| 23 | Condenser | | 3A4309-01 | 1 | | | | | | | | |
| 24 | Fan Motor | | 4A0408-01 | 1 | | | | | | | | |
| 25 | Fan Blade | | 3A0608-01 | 1 | | | | | | | | |
| 26 | Drier | | 445655-04 | 1 | | | | | | | | |
| 27 | Heat Exchanger | | 2A7808G01 | 1 | | | | | | | | |
| 28 | High-Pressure Switch | | 463180-04 | 1 | | | | | | | | |

B. Icemaking Unit
F-330BAJ(-C)
 E-0 to J-1

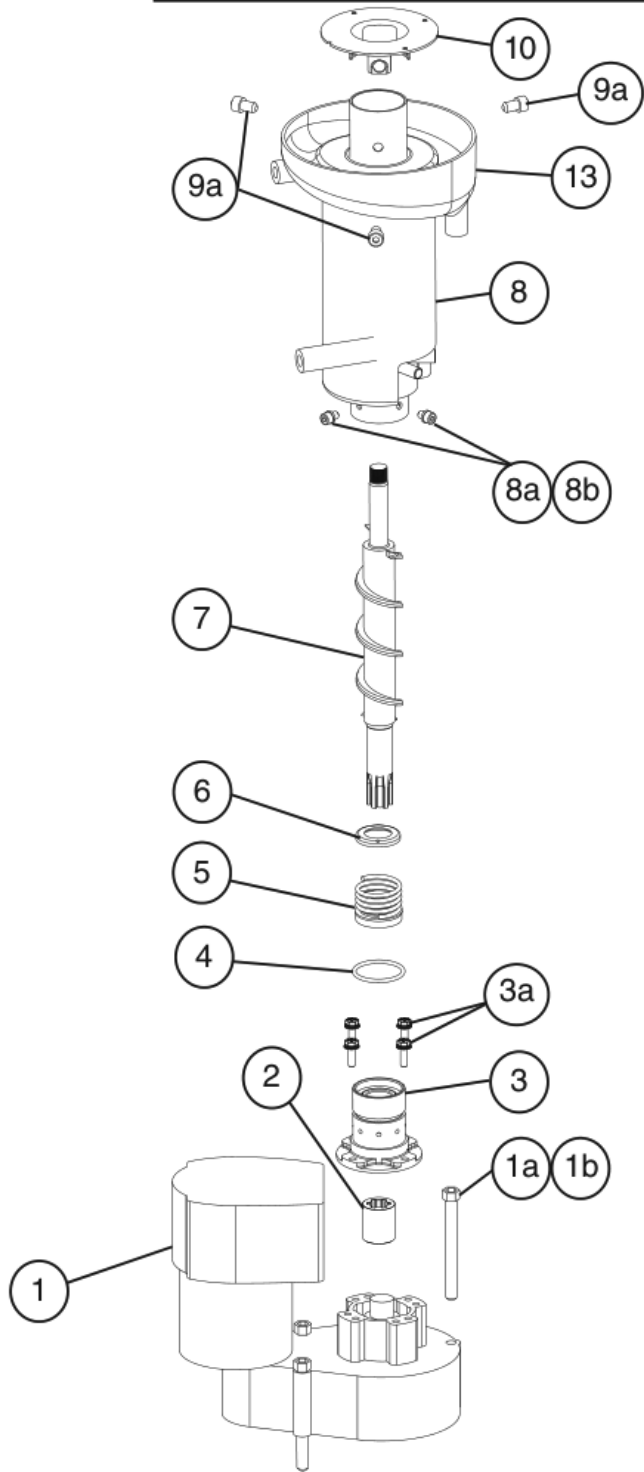
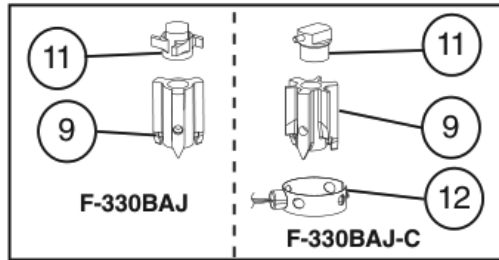

| Title: B. Icemaking Unit Model: F-330BAJ(-C) | | | | | | | | | | | |
|--|-----------------------|--------------------------|-------------|-----------------|------------|--|--|--|--|--|--|
| Index No. | Description | Material or Model Number | Part Number | Required Number | | | | | | | |
| | | | | E-0 to G-2 | H-0 to J-1 | | | | | | |
| 1 | Gear Motor | | 4A5439-01 | 1 | - | | | | | | |
| | | | 2U0147-01 | | 1 | | | | | | |
| 1a | Socket Head Cap Screw | | 7S12-0895 | 3 | 3 | | | | | | |
| 1b | Split Lock Washer | | 7L22-0800 | 3 | 3 | | | | | | |
| 2 | Spline Coupling | | 418316-01 | 1 | 1 | | | | | | |
| 3 | Housing | | 383613G01 | 1 | 1 | | | | | | |
| 3a | Bolt | | 4A1989-01 | 4 | 4 | | | | | | |
| 4 | O-Ring | | 4A4755-01 | 1 | 1 | | | | | | |
| 5 | Mechanical Seal | | 432491-01 | 1 | 1 | | | | | | |
| 6 | Ring (B) | | 432494-01 | 1 | 1 | | | | | | |
| 7 | Auger | | 269909G01 | 1 | 1 | | | | | | |
| 8 | Evaporator | | 2A7797G01 | 1 | 1 | | | | | | |
| 8a | Split Lock Washer | M6, SS | 7L22-0600 | 4 | 4 | | | | | | |
| 8b | Socket Head Cap Screw | 6x10, SS | 7S12-0610 | 4 | 4 | | | | | | |
| 9 | Extruding Head | F-330BAJ | 340077G02 | 1 | 1 | | | | | | |
| | | F-330BAJ-C | 327141G03 | 1 | 1 | | | | | | |
| 9a | Seal Bolt | | P01768-02 | 3 | 3 | | | | | | |
| 10 | Flange | | 464843-01 | 1 | 1 | | | | | | |
| 11 | Cutter | F-330BAJ | 453790-01 | 1 | 1 | | | | | | |
| | | F-330BAJ-C | 439228G01 | 1 | 1 | | | | | | |
| 12 | Evaporator Heater | F-330BAJ-C | 4A4375-01 | 1 | 1 | | | | | | |
| 13 | Drip Pan | | 2A4118-01 | 1 | 1 | | | | | | |

C. Water Circuit
F-330BAJ(-C)
E-0 to J-1

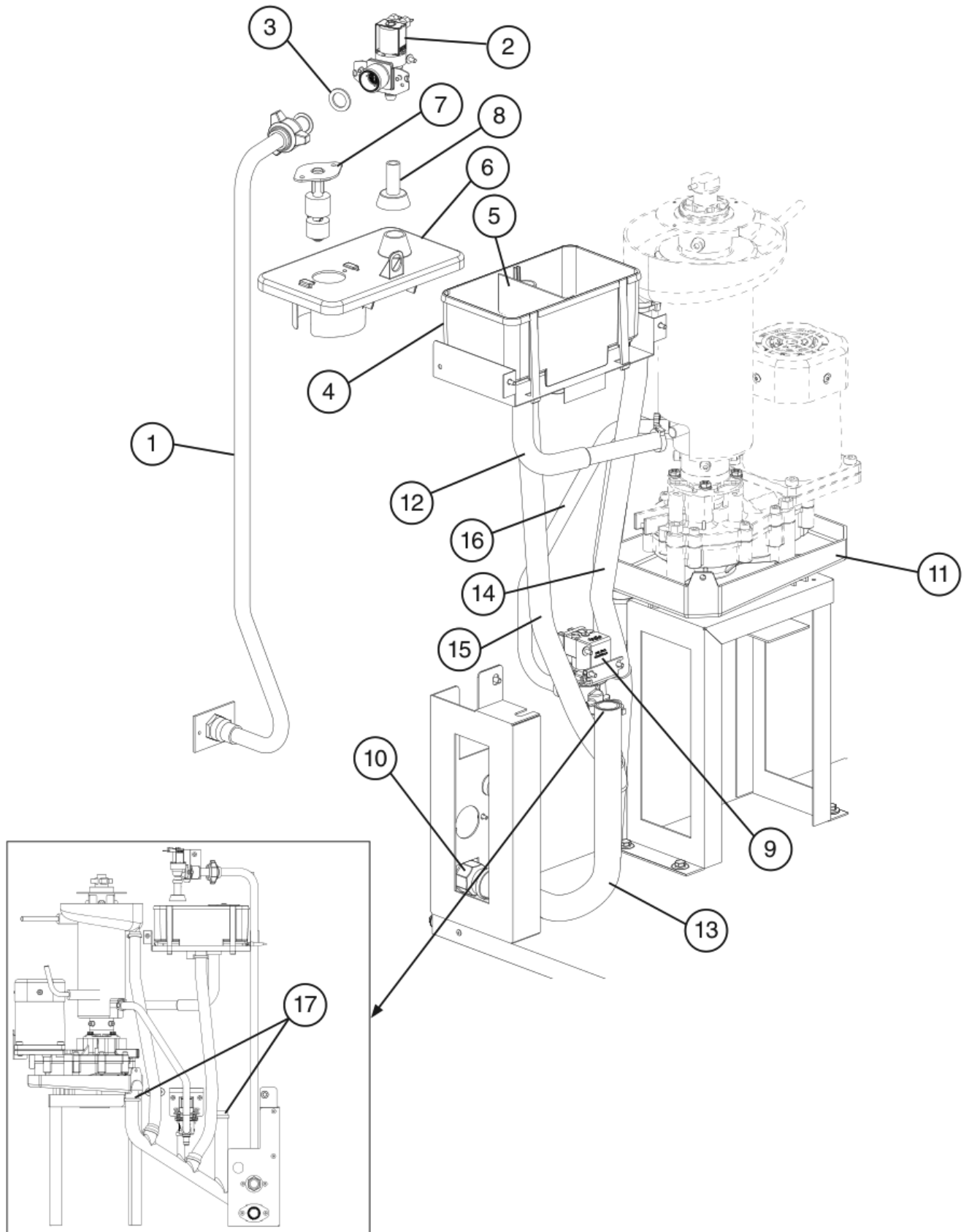

Title: C. Water Circuit Model: F-330BAJ(-C)

| Index No. | Description | Material or Model Number | Part Number | Required Number | | | | | | | | | | | | | | | | |
|-----------|----------------------------------|--------------------------|---------------------------|-----------------|--|--|--|--|--|--|--|--|--|--|--|--|--|--|--|--|
| | | | | E-0 to J-1 | | | | | | | | | | | | | | | | |
| 1 | Water Supply Pipe | | 3A4298G02 | 1 | | | | | | | | | | | | | | | | |
| 2 | Inlet Water Valve | S-30 | 4A5309-01 | 1 | | | | | | | | | | | | | | | | |
| 3 | Washer | | 413854-03 | 1 | | | | | | | | | | | | | | | | |
| 4 | Reservoir | | 2A0753-01 | 1 | | | | | | | | | | | | | | | | |
| 5 | Reservoir Separator | | 4A1255-01 | 1 | | | | | | | | | | | | | | | | |
| 6 | Reservoir Cover | | 214810-01 | 1 | | | | | | | | | | | | | | | | |
| 7 | Float Switch | | 435490-01 | 1 | | | | | | | | | | | | | | | | |
| 8 | Reservoir Inlet | | 4A0869-01 | 1 | | | | | | | | | | | | | | | | |
| 9 | Drain Valve | | 4A2772-02 | 1 | | | | | | | | | | | | | | | | |
| 10 | Drain Fitting | | 4A5527-01 | 1 | | | | | | | | | | | | | | | | |
| 11 | Drain Pan | | 323765G01 | 1 | | | | | | | | | | | | | | | | |
| 12 | Reservoir Hose | | 4A1165-13 | 1 | | | | | | | | | | | | | | | | |
| 13 | Drain Hose | | 3A8113-01 | 1 | | | | | | | | | | | | | | | | |
| 14 | Vinyl Hose (drip pan hose) | L= 475 mm | 7725-1923 | 1 | | | | | | | | | | | | | | | | |
| 15 | Vinyl Hose (reservoir overflow) | L= 460 mm | 7725-1923 | 1 | | | | | | | | | | | | | | | | |
| 16 | Silicone Hose (evaporator drain) | L= 390 mm | 773013896 | 1 | | | | | | | | | | | | | | | | |
| 17 | Vinyl Hose | L=30 mm | 7716-2025 | 2 | | | | | | | | | | | | | | | | |

Hose Clamps

| | | | | | | | | | | | | | | | | | | | | |
|--|------------|------------|---------------------------|---|--|--|--|--|--|--|--|--|--|--|--|--|--|--|--|--|
| | Hose Clamp | 13.5-15 mm | 4A2017-08 | 1 | | | | | | | | | | | | | | | | |
| | Hose Clamp | 21-26 mm | 4A2017-01 | 1 | | | | | | | | | | | | | | | | |
| | Hose Clamp | 17-21 mm | 4A2017-05 | 1 | | | | | | | | | | | | | | | | |
| | Hose Clamp | 15-17 mm | 4A2017-07 | 3 | | | | | | | | | | | | | | | | |

D. Control Box Assembly
F-330BAJ(-C)
 E-0 to J-1

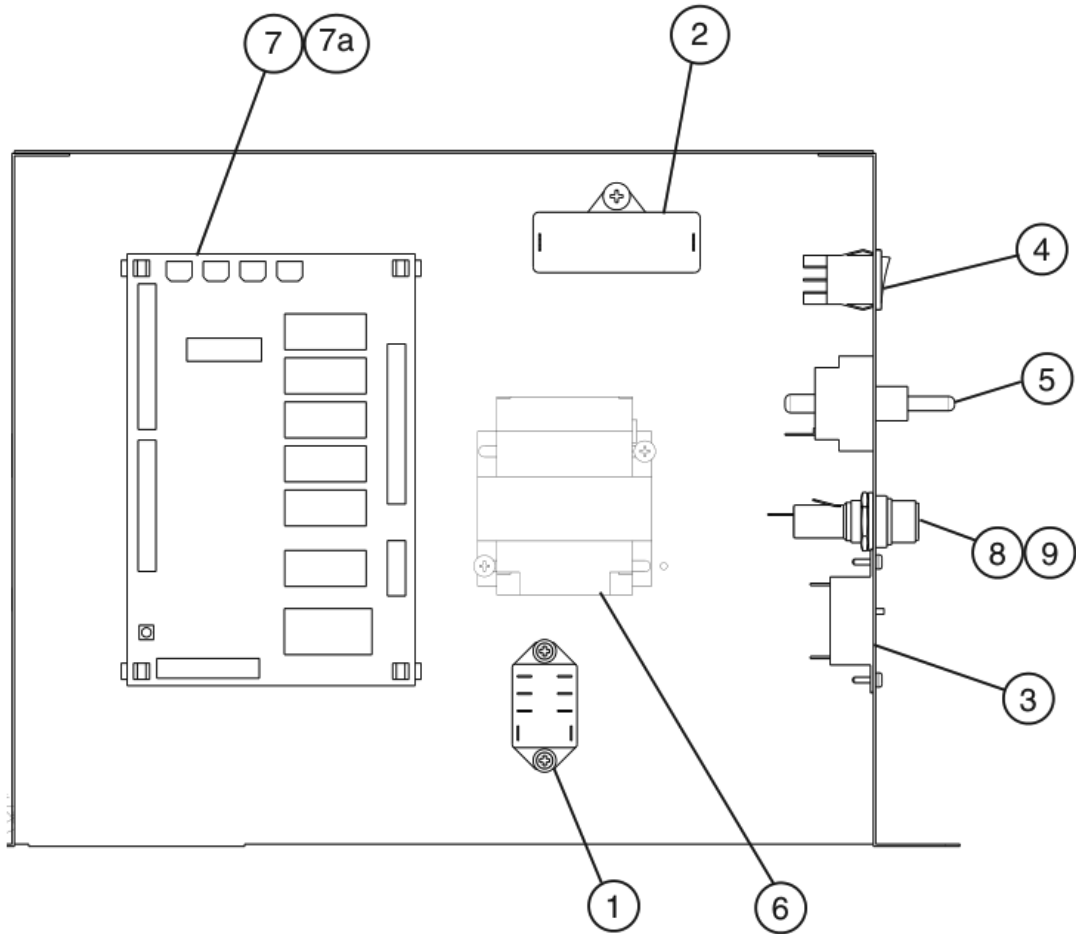

| Title: D. Control Box Assembly Model: F-330BAJ(-C) | | | | Required Number | | | | | | | | |
|--|--------------------------|--------------------------|-------------|-----------------|-----|------------|---|--|--|--|--|--|
| Index No. | Description | Material or Model Number | Part Number | E-0 to G-2 | H-0 | H-1 to J-1 | | | | | | |
| 1 | Compressor Control Relay | | 406132-07 | 1 | 1 | 1 | | | | | | |
| 2 | Gear Motor Capacitor | 10MFD, 250VAC | 443192-01 | 1 | 1 | 1 | | | | | | |
| 3 | Protector | 1.6A | 427253-01 | 1 | - | | | | | | | |
| | | 1.0A | 4A6087-01 | | 1 | - | | | | | | |
| | | 2.0A | P04531-02 | | | | 1 | | | | | |
| 4 | Control Switch | | 4A0558-01 | 1 | 1 | 1 | | | | | | |
| 5 | Power Switch | | 4A2332-01 | 1 | 1 | 1 | | | | | | |
| 6 | Control Transformer | | 4A0507-01 | 1 | 1 | 1 | | | | | | |
| 7 | Control Board | | 2A9093-01 | 1 | 1 | 1 | | | | | | |
| 7a | Control Board Support | | 4A0336-03 | 4 | 4 | 4 | | | | | | |
| 8 | Fuse Holder | | 4A5443-01 | 1 | 1 | 1 | | | | | | |
| 9 | Fuse | AGC-3A, 250VAC | 4A0893-03 | 1 | 1 | 1 | | | | | | |

E. Accessories & Labels
F-330BAJ(-C)
 E-0 to J-1

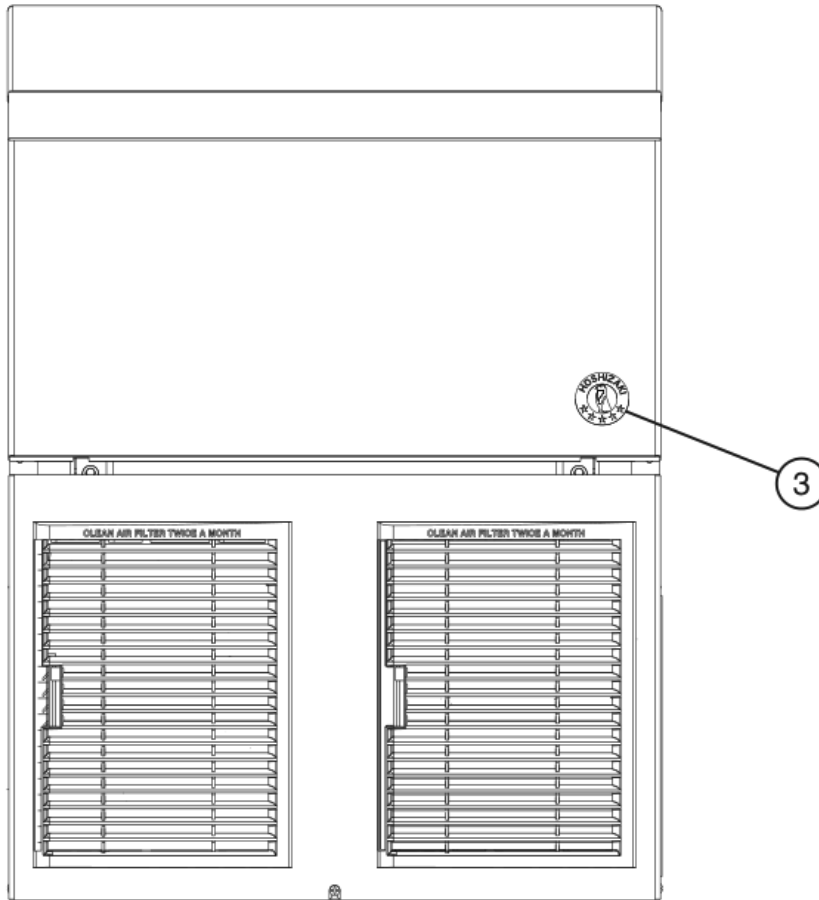

| Title: E. Accessories & Labels | | Model: F-330BAJ(-C) | | Required Number | | | | | | | | |
|--------------------------------|---------------|--------------------------|-------------|-----------------|--|--|--|--|--|--|--|--|
| Index No. | Description | Material or Model Number | Part Number | E-0 to J-1 | | | | | | | | |
| 1 | Scoop | | 1H4123P02 | 1 | | | | | | | | |
| 2 | Control Label | | 4A5996-01 | 1 | | | | | | | | |
| 3 | Penguin Label | | 475552L01 | 1 | | | | | | | | |