NO. 71139

ISSUED: DEC. 9, 1998

REVISED: SEPT. 10, 2002



**HOSHIZAKI
MODULAR FLAKER**

MODEL

F-800MAF(-C)

F-800MWF(-C)

(FINAL) PARTS LIST

F-800MAF	H-0	APRIL 1998
	J-0	DEC. 1998
	K-0	DEC. 1999
	K-1	SEPT. 2000
	L-0	DEC. 2000

F-800MAF-C	H-0	SEPT. 1998
	J-0	SEPT. 1999
	K-1	DEC. 1999
	K-2	SEPT. 2000
	L-0	JAN. 2001

F-800MWF	H-0	APR. 1998
	J-0	FEB. 1999
	K-1	DEC. 1999
	K-2	SEPT. 2000
	L-0	DEC. 2000

F-800MWF-C	H-0	SEP. 1998
	J-0	FEB. 1999
	K-0	DEC. 1999
	K-1	SEPT 2000

MATERIAL ABBREVIATIONS

ALUMINUM

AL = Aluminum

COPPER

CU = Copper

PLASTIC

ABS = Acrylonitrile -butadiene - styrene
 AC = Polyacetal
 EVA = Ethylene vinyl acetate
 PA = Polyamide = Nylon
 PC = Polycarbonate
 PE = Polyethylene
 PES = Polyester
 PETP = Polyethylene terephthalate = Tetlon
 PP = Polypropylene
 PS = Polystyrene
 PTFE = Polytetrafluoroethylene = Teflon
 PUR = Polyurethane
 PVC = Polyvinyl chloride

RUBBER

VN = Vinyl Nitrile
 EPDM = EP rubber
 NBR = Nitrile butadiene rubber
 NR = Natural rubber
 NP = Neoprene
 SI.R = Silicone rubber
 SY.R = Synthetic rubber
 EPH = Epichlorohydrin

STEEL

GS = Galvanized steel
 SS = Stainless steel
 PS = Plated steel
 PAS = Primed steel

AUXILIARY CODE

Ex.1

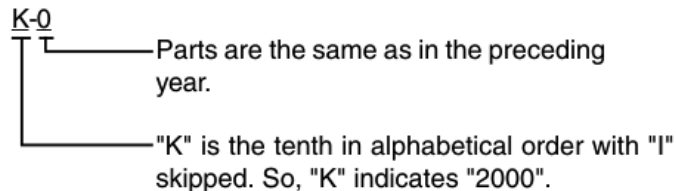

(Note) - = Part deleted.

x = Part deleted and replaced by "o" (interchangeable) part.

Ex.2

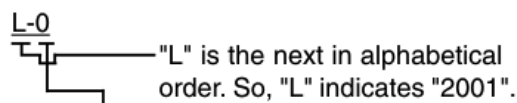

o = New part for "x" in the same auxiliary code.

Ex.3

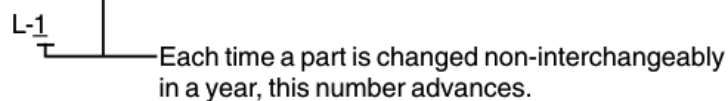

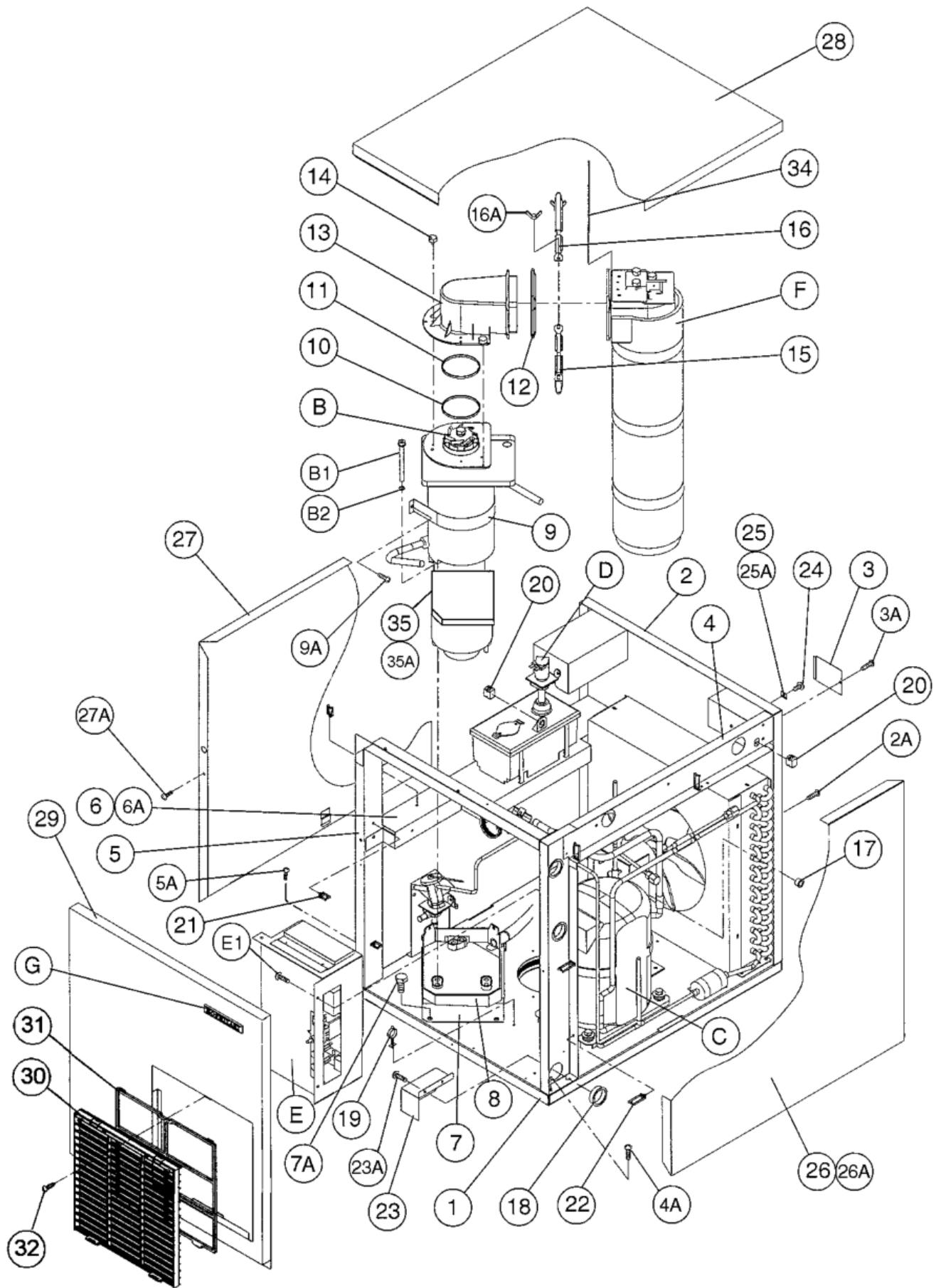

MODEL: F-800MAF		TITLE: A. ICE FLAKER ASSEMBLY						
INDEX NO.	DESCRIPTION	MATERIAL OR MODEL NUMBER	PART NUMBER	REQUIRED NUMBER				
				H-0 J-0	K-0	K-1	L-0	
B	ICE MAKING UNIT	-	3A0962A03	1	1	x1		
		-	3A0962A01			o1	1	
B1	SOCKET HEAD HEX BOLT	8X95, SS	7S12-0895	3	3	3	3	
B2	SPRING WASHER	8, SS	7L22-0800	3	3	3	3	
C	REFRIGERATION UNIT	-	2A1000A01	1	x1			
		-	2A1000A02		o1	1	1	
D	WATER CIRCUIT	-	2A0968A01	1	1	1	1	
E	CONTROL BOX ASSEMBLY	-	2A1045A03	1	x1			
			2A1045A05		o1	1	1	
E1	TRUSS HEAD SCREW	4X8	7C31-0408	3	3	3	3	
F	CHUTE ASSEMBLY	-	2A0941A02	1	-			
		-	2A1705A02		1	1	1	
G	LABEL LOCATION	-	2A1038A01	1	x1			
		-	2A1038A05		o1	1	1	

MODEL: F-800MAF(-C)		TITLE: A. ICE FLAKER ASSEMBLY						
INDEX NO.	DESCRIPTION	MATERIAL OR MODEL NUMBER	PART NUMBER	REQUIRED NUMBER				
				H-0 J-0	K-0	K-1	K-2	L-0
1	CHASSIS	GS	2A1176G01	1	1	1	1	1
2	REAR PANEL	GS	2A0322G02	1	1	1	1	1
2A	T2 SCREW	4X8	7P31-0408	4	4	4	4	4
3	JUNCTION BOX COVER	GS	433410-01	1	1	1	1	1
3A	T2 SCREW	4X8	7P31-0408	1	1	1	1	1
4	SIDE FRAME (R)	GS	2A1047G01	1	1	1	1	1
4A	TRUSS HEAD SCREW	4X8	7C31-0408	2	2	2	2	2
5	FRONT FRAME	GS	3A0324G01	1	1	1	1	1
5A	TRUSS HEAD SCREW	4X8	7C31-0408	2	2	2	2	2
6	RESERVOIR BRACKET	GS	2A1060-01	1	1	1	1	1
6A	T2 SCREW	4X8	7P31-0408	4	4	4	4	4
7	BRACKET – GEAR MOTOR	GS	3A0396G01	1	1	1	1	1
7A	HEX BOLT	8X12, SS	7B02-0812	2	2	2	2	2
8	DRAIN PAN	ABS	323765G02	1	1	1	1	1
9	STRAP	GS	4A1474-01	1	1	1	1	1
9A	T3 SCREW	5X12	7G31-0512	2	2	2	2	2
10	RING	PA	432661-02	1	1	1	1	1
11	“O” RING	G70	7616-G070	1	1	1	1	1
12	PACKING-SPOUT	EPDM	321037-01	1	1	1	1	1
13	SPOUT	PC	104797-01	1	1	1	1	1
14	THUMBSCREW	SS, ABS	415949G04	3	3	3	3	3
15	STRAP	SS	321038G02	1	1	1	1	1
16	STRAP	SS	328703-02	1	1	1	1	1
16A	WING NUT	6, SS	7E12-0600	2	2	2	2	2
17	BUSHING	SB-1500-21	420470-09	1	1	1	1	1
18	BUSHING	SB-1500-21	420470-06	3	3	3	3	3
19	CLAMP	WS75-75-C	4A0337-12	3	3	3	3	3
20	BUSHING	SR-30-1	420472-03	2	2	2	2	2
21	WIRE SADDLE	LWS-2NS	4A0338-02	5	5	5	5	5
22	WIRE SADDLE	LWS-4NS	4A0338-04	4	4	4	4	4

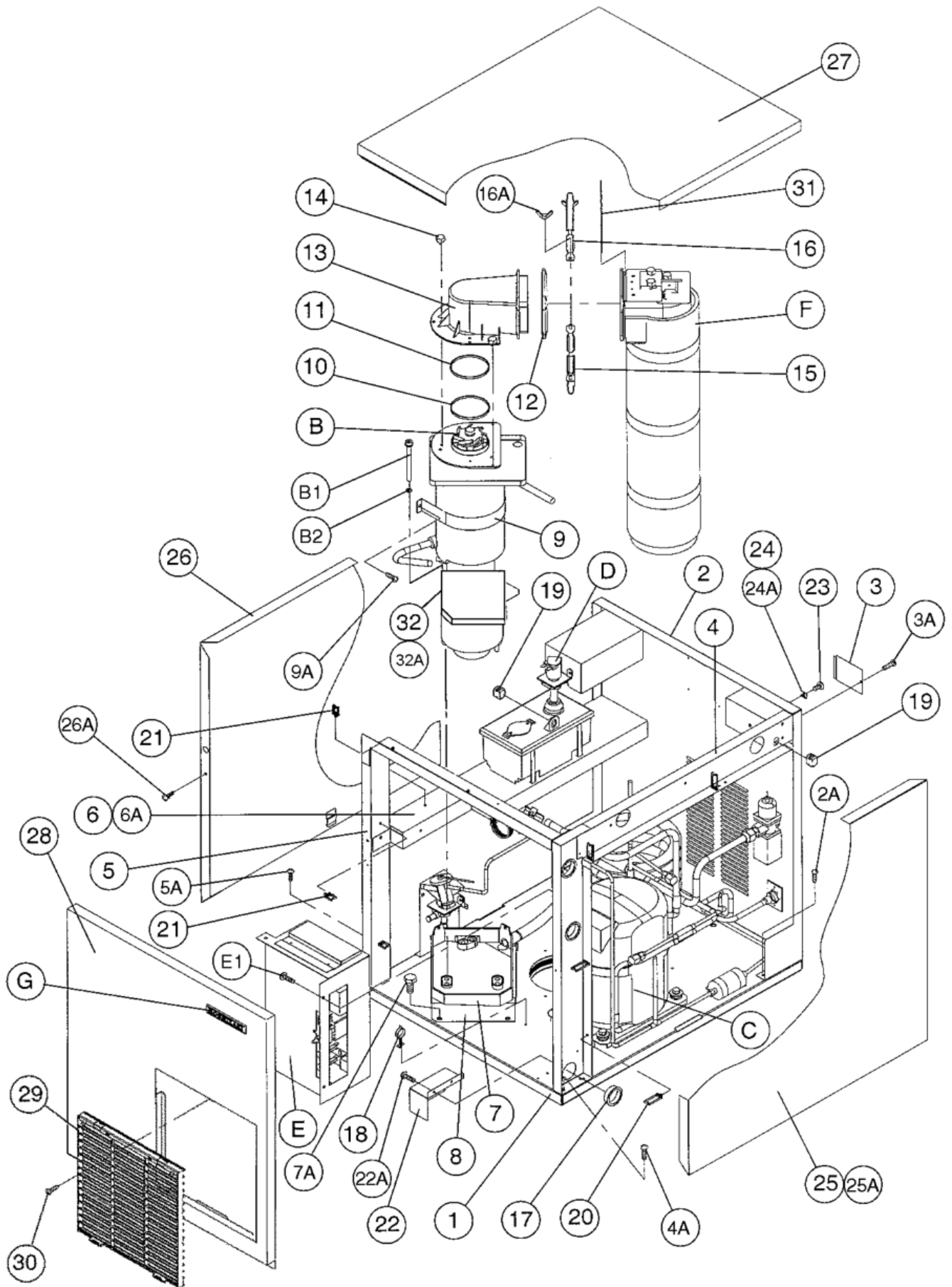

MODEL: F-800MWF-C		TITLE: A. ICE FLAKER ASSEMBLY						
INDEX NO.	DESCRIPTION	MATERIAL OR MODEL NUMBER	PART NUMBER	REQUIRED NUMBER				
				H-0 J-0	K-0	K-1		
B	ICE MAKING UNIT	-	3A0962A04	1	1	x1		
		-	3A0962A02			o1		
B1	SOCKET HEAD HEX BOLT	8X95, SS	7S12-0895	3	3	3		
B2	SPRING WASHER	8, SS	7L22-0800	3	3	3		
C	REFRIGERATION UNIT	-	2A1024A01	1	x1			
		-	2A1024A02		o1	1		
D	WATER CIRCUIT	-	2A0968A01	1	1	1		
E	CONTROL BOX ASSEMBLY	-	2A1045A04	1	x1			
		-	2A1045A06		o1	1		
E1	TRUSS HEAD SCREW	4X8	7C31-0408	3	3	3		
F	CHUTE ASSEMBLY	-	2A0941A02	1	-			
		-	2A1705A02		1	1		
G	LABEL LOCATION	-	2A1038A04	1	x1			
		-	2A1038A08		o1	1		

MODEL: F-800MWF(-C)			TITLE: A. ICE FLAKER ASSEMBLY					
INDEX NO.	DESCRIPTION	MATERIAL OR MODEL NUMBER	PART NUMBER	REQUIRED NUMBER				
				H-0 J-0	K-0	K-1	K-2	L-0
1	CHASSIS	GS	2A1176G01	1	1	1	1	1
2	REAR PANEL	GS	2A1012G01	1	1	1	1	1
2A	T2 SCREW	4X8	7P31-0408	4	4	4	4	4
3	JUNCTION BOX COVER	GS	433410-01	1	1	1	1	1
3A	T2 SCREW	4X8	7P31-0408	1	1	1	1	1
4	SIDE FRAME (R)	GS	2A1047G01	1	1	1	1	1
4A	TRUSS HEAD SCREW	4X8	7C31-0408	2	2	2	2	2
5	FRONT FRAME	GS	3A0324G01	1	1	1	1	1
5A	TRUSS HEAD SCREW	4X8	7C31-0408	2	2	2	2	2
6	RESERVOIR BRACKET	GS	2A1059-01	1	1	1	1	1
6A	T2 SCREW	4X8	7P31-0408	4	4	4	4	4
7	BRACKET – GEAR MOTOR	GS	3A0396G01	1	1	1	1	1
7A	HEX BOLT	8X12, SS	7B02-0812	2	2	2	2	2
8	DRAIN PAN	ABS	323765G02	1	1	1	1	1
9	STRAP	GS	4A1474-01	1	1	1	1	1
9A	T3 SCREW	5X12	7G31-0512	2	2	2	2	2
10	RING	PA	432661-02	1	1	1	1	1
11	“O” RING	G70	7616-G070	1	1	1	1	1
12	PACKING-SPOUT	EPDM	321037-01	1	1	1	1	1
13	SPOUT	PC	104797-01	1	1	1	1	1
14	THUMBSCREW	SS, ABS	415949G04	3	3	3	3	3
15	STRAP	SS	321038G02	1	1	1	1	1
16	STRAP	SS	328703-02	1	1	1	1	1
16A	WING NUT	6, SS	7E12-0600	2	2	2	2	2
17	BUSHING	SB-1500-21	420470-06	3	3	3	3	3
18	CLAMP	WS75-75-C	4A0337-12	3	3	3	3	3
19	BUSHING	SR-30-1	420472-03	2	2	2	2	2
20	WIRE SADDLE	LWS-2NS	4A0338-02	5	5	5	5	5
21	WIRE SADDLE	LWS-4NS	4A0338-04	4	4	4	4	4
22	BARRIER	GS	4A0688-01	1	1	1	1	1

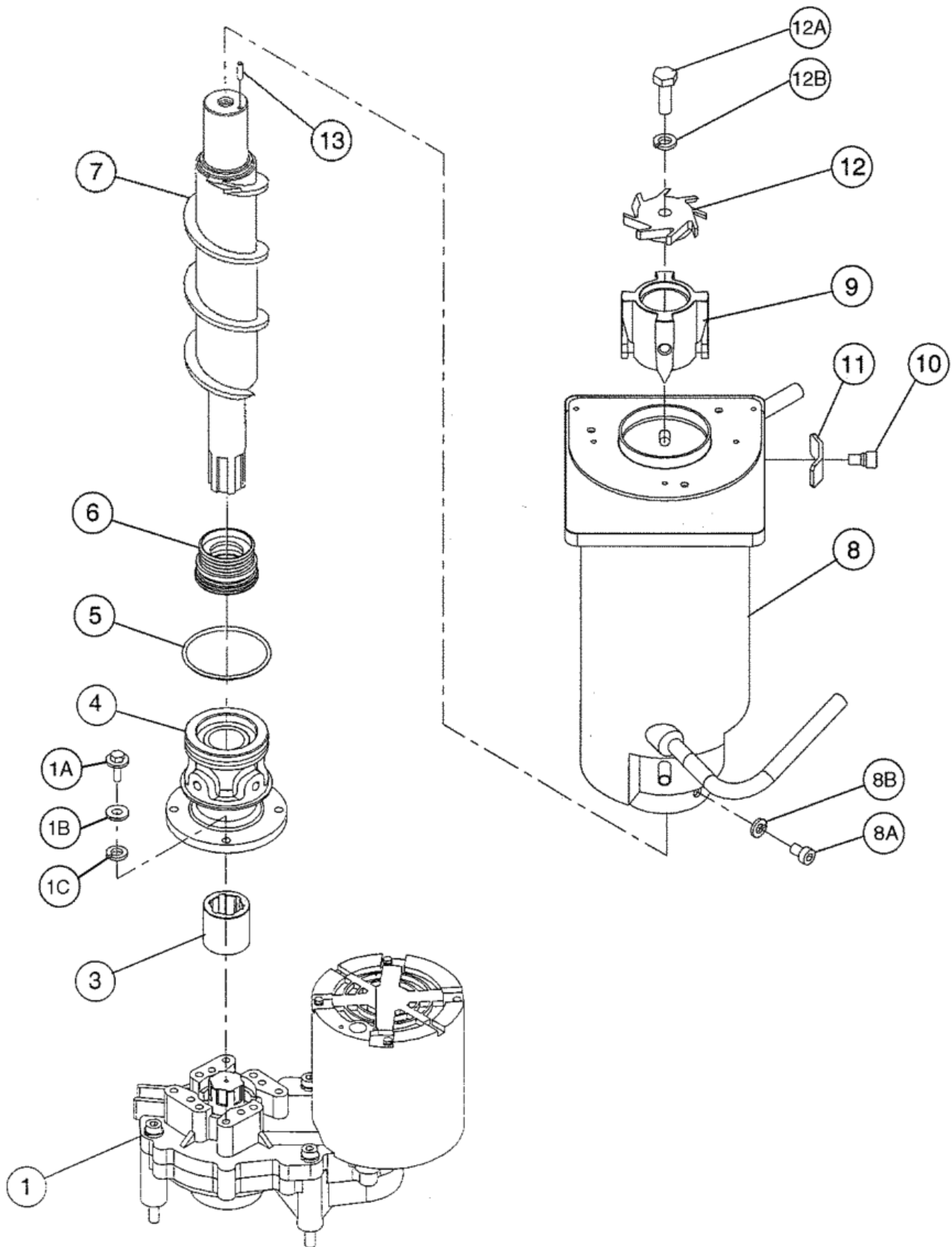

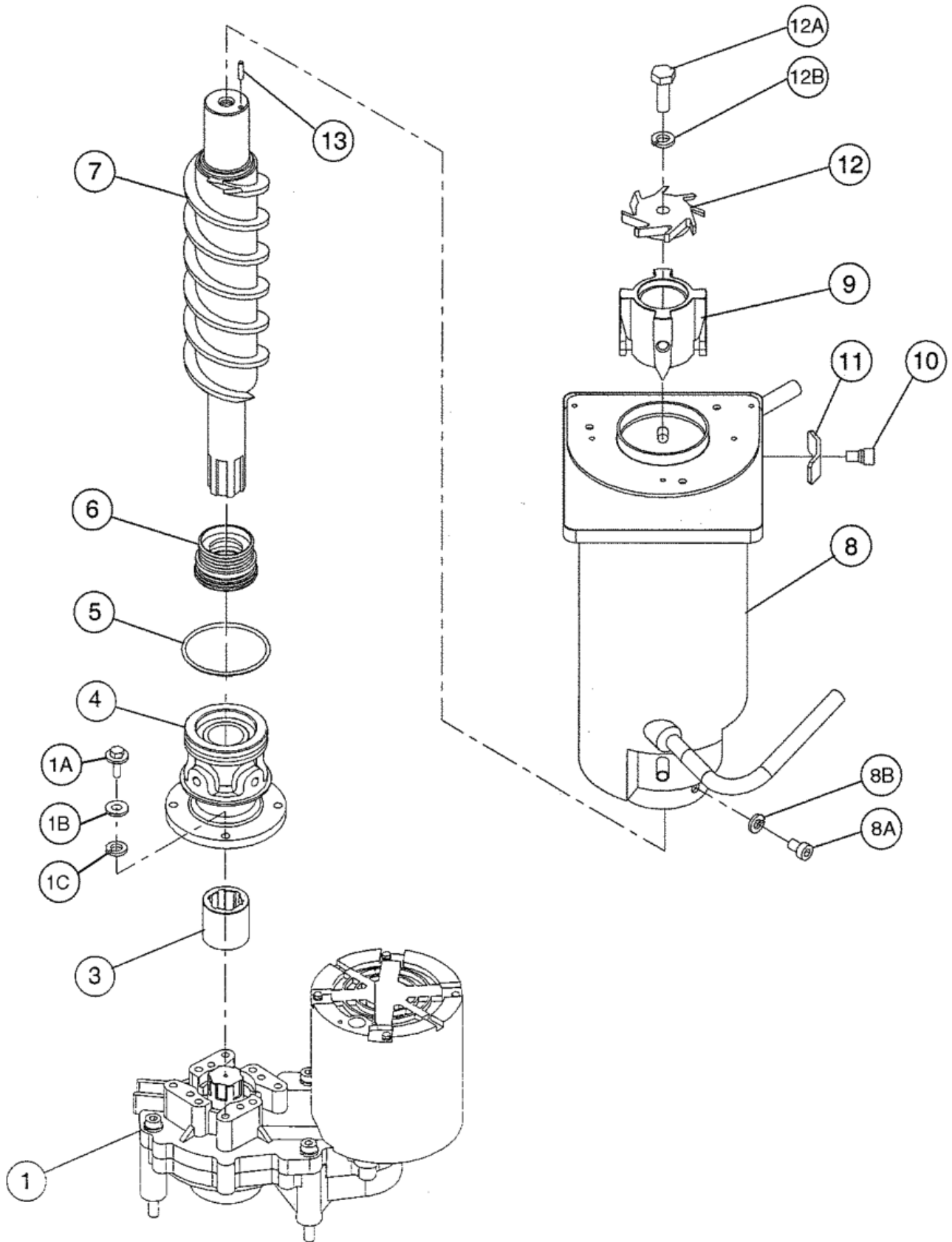

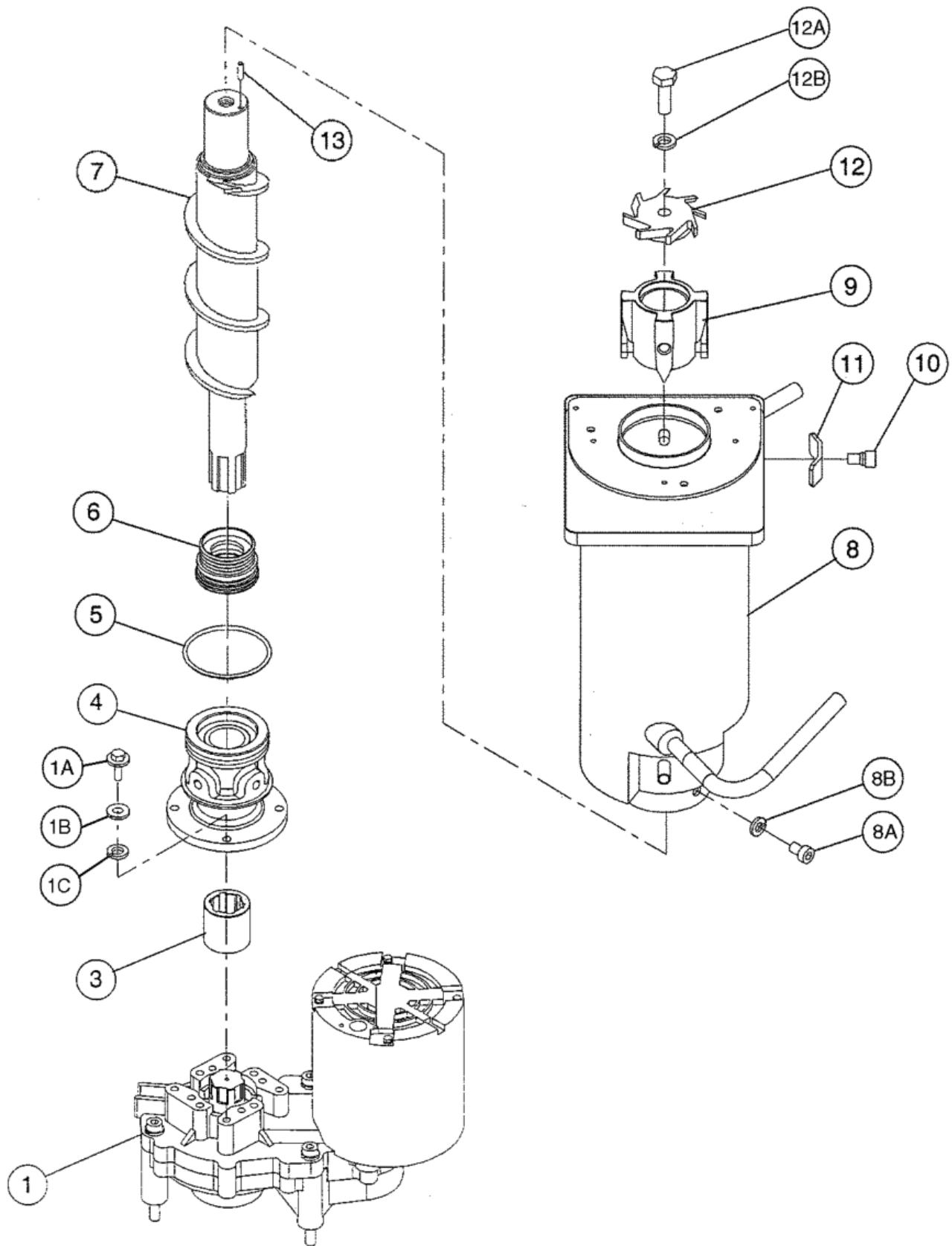

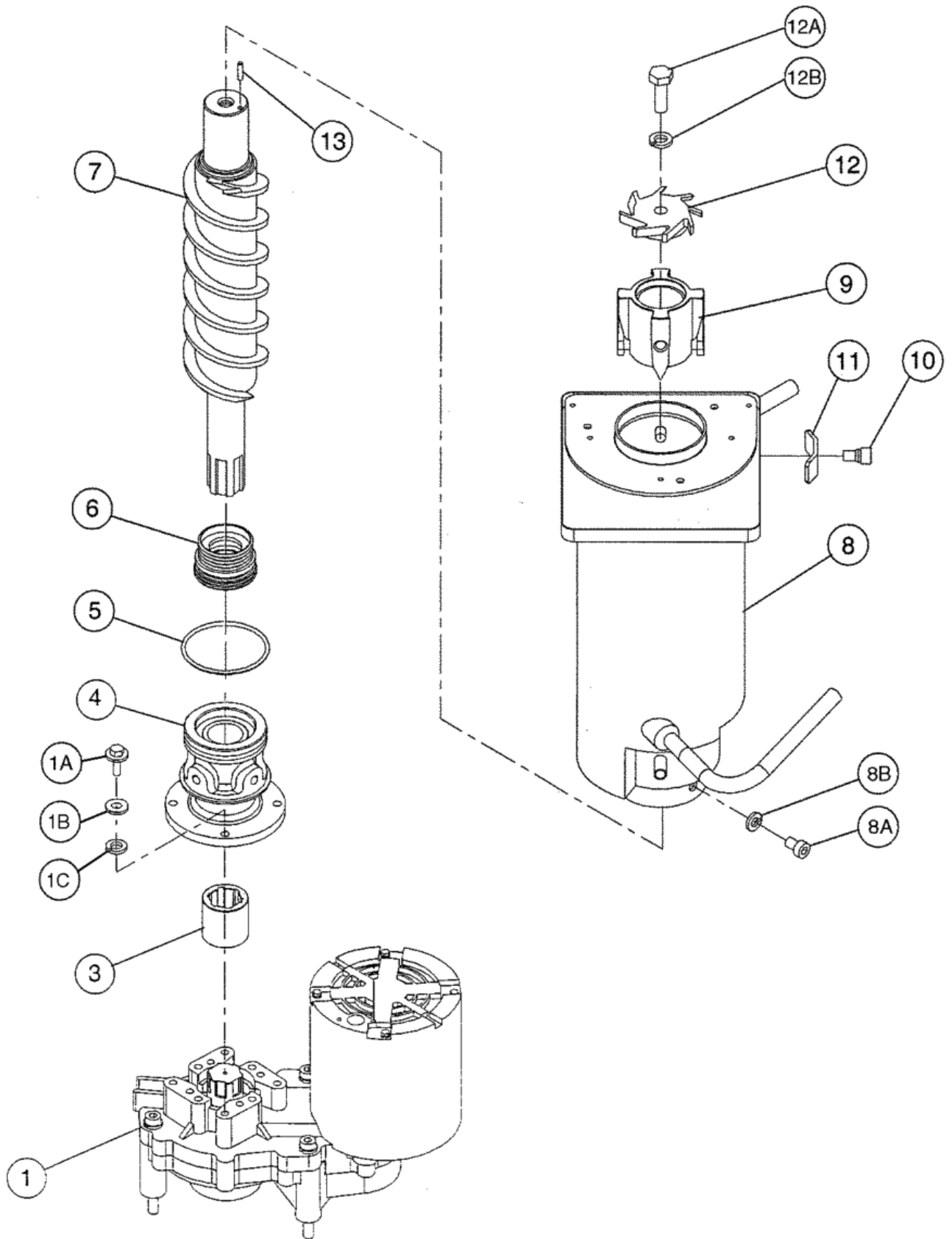

MODEL: F-800MAF		TITLE: B. ICE MAKING UNIT						
INDEX NO.	DESCRIPTION	MATERIAL OR MODEL NUMBER	PART NUMBER	REQUIRED NUMBER				
				H-0 J-0	K-0	K-1	L-0	
1	GEAR MOTOR	-	4A1296-01	1	x1			
		-	4A2194-01		o1	1	1	
1A	BOLT	6X20	458660-01	4	4	4	4	
1B	PLAIN WASHER	6.4X12.5X1.6, SS	7W22-0616	4	4	4	4	
1C	SPRING WASHER	6, SS	7L22-0600	4	4	4	4	
2	-	-	-					
3	COUPLING - SPLINE	SS	4A1297-01	1	1	1	1	
4	HOUSING	BRASS	2A0947G01	1	1	1	1	
5	"O" RING	G65	7616-G065	1	1	1	1	
6	MECHANICAL SEAL	HK9A-MN	432492-01	1	1	1	1	
7	AUGER	SS	2A0960G02	1	1	x1		
		SS	2A0932G02			o1	1	
8	EVAPORATOR	-	2A1227G01	1	1	1	1	
8A	SOCKET HEAD CAP SCREW	8X12, SS	7S12-0812	4	4	4	4	
8B	SPLIT LOCK WASHER	8, SS	7L22-0800	4	4	4	4	
9	EXTRUDING HEAD / 70F	SS	3A2175G01	1	1	1	1	
10	SOCKET HEAD CAP SCREW	SS, M10X15	429121-01	4	4	4	4	
11	WASHER	SS	427184-01	4	4	4	4	
12	CUTTER	SS	317071-02	x1				
		SS	3A1395-02	o1	1	1	1	
12A	HEX HEAD BOLT	10X30, SS	7B02-1030	1	1	1	1	
12B	SPLIT LOCK WASHER	10, SS	7L22-1000	1	1	1	1	
13	DOWEL PIN	SS, 4 x 16	713S-0416	1	1	1	1	

MODEL: F-800MWF		TITLE: B. ICE MAKING UNIT					
INDEX NO.	DESCRIPTION	MATERIAL OR MODEL NUMBER	PART NUMBER	REQUIRED NUMBER			
				H-0 J-0	K-1	K-2	L-0
1	GEAR MOTOR	-	4A1296-01	1	x1		
		-	4A2194-01		o1	1	1
1A	BOLT	6X20	458660-01	4	4	4	4
1B	PLAIN WASHER	6.4X12.5X1.6, SS	7W22-0616	4	4	4	4
1C	SPRING WASHER	6, SS	7L22-0600	4	4	4	4
2	-	-	-				
3	COUPLING - SPLINE	SS	4A1297-01	1	1	1	1
4	HOUSING	BRASS	2A0947G01	1	1	1	1
5	"O" RING	G65	7616-G065	1	1	1	1
6	MECHANICAL SEAL	HK9A-MN	432492-01	1	1	1	1
7	AUGER	SS	2A0960G02	1	1	x1	
		SS	2A0932G02			o1	1
8	EVAPORATOR	-	2A1227G01	1	1	1	1
8A	SOCKET HEAD CAP SCREW	8X12, SS	7S12-0812	4	4	4	4
8B	SPLIT LOCK WASHER	8, SS	7L22-0800	4	4	4	4
9	EXTRUDING HEAD / 70F	SS	3A2175G01	1	1	1	1
10	SOCKET HEAD CAP SCREW	SS, M10X15	429121-01	4	4	4	4
11	WASHER	SS	427184-01	4	4	4	4
12	CUTTER	SS	317071-02	x1			
		SS	3A1395-02	o1	1	1	1
12A	HEX HEAD BOLT	10X30, SS	7B02-1030	1	1	1	1
12B	SPLIT LOCK WASHER	10, SS	7L22-1000	1	1	1	1
13	DOWEL PIN	SS, 4 x 16	713S-0416	1	1	1	1

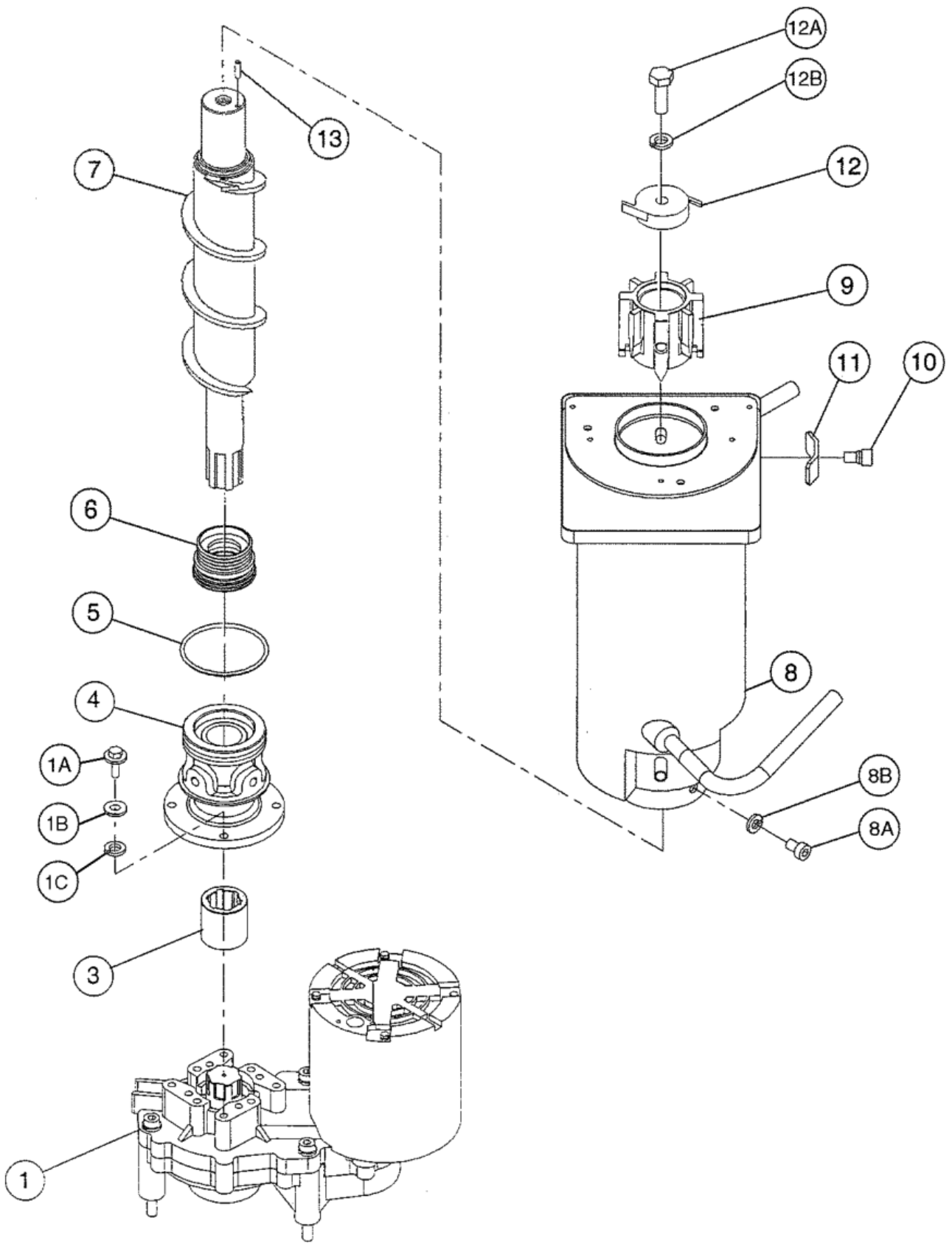

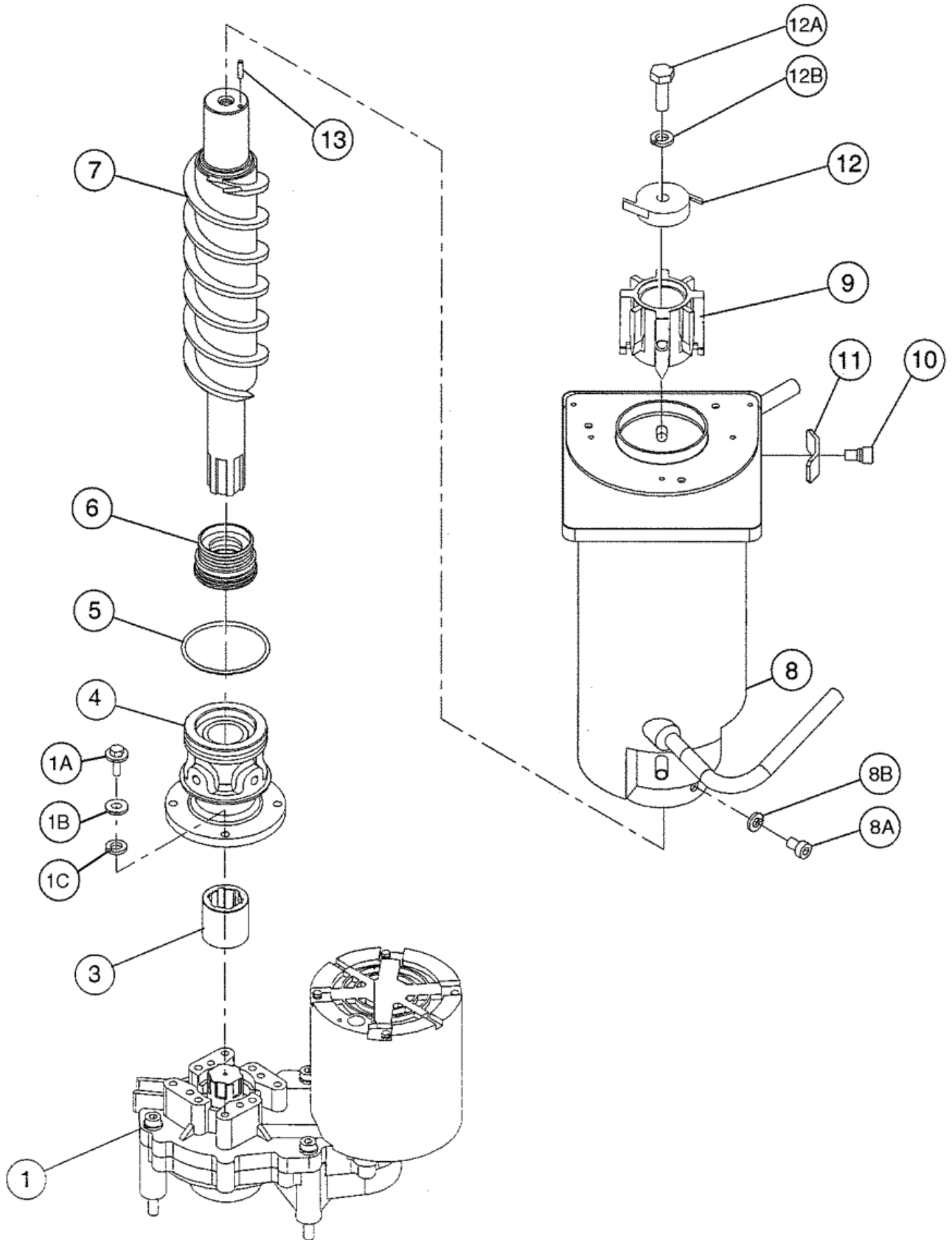

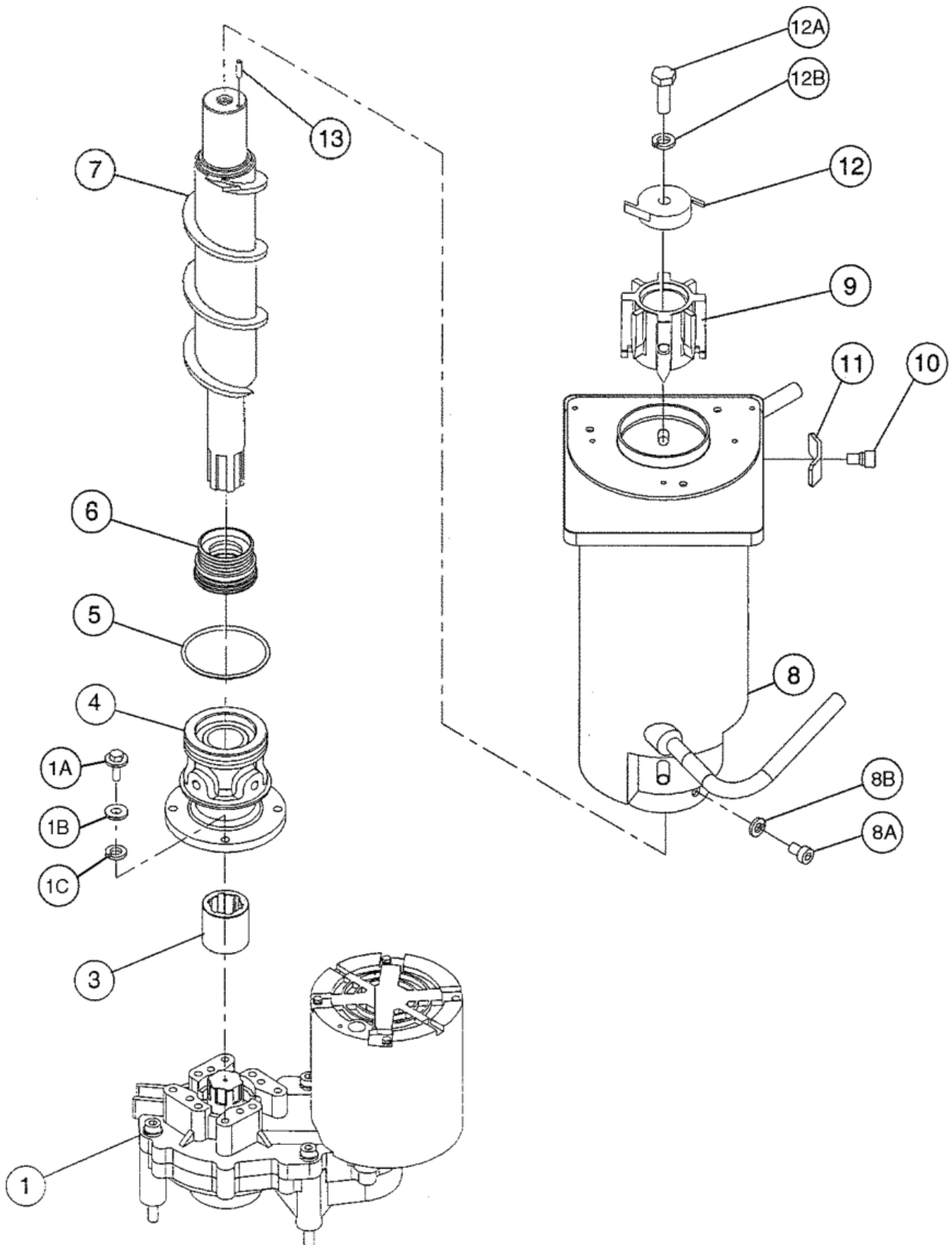

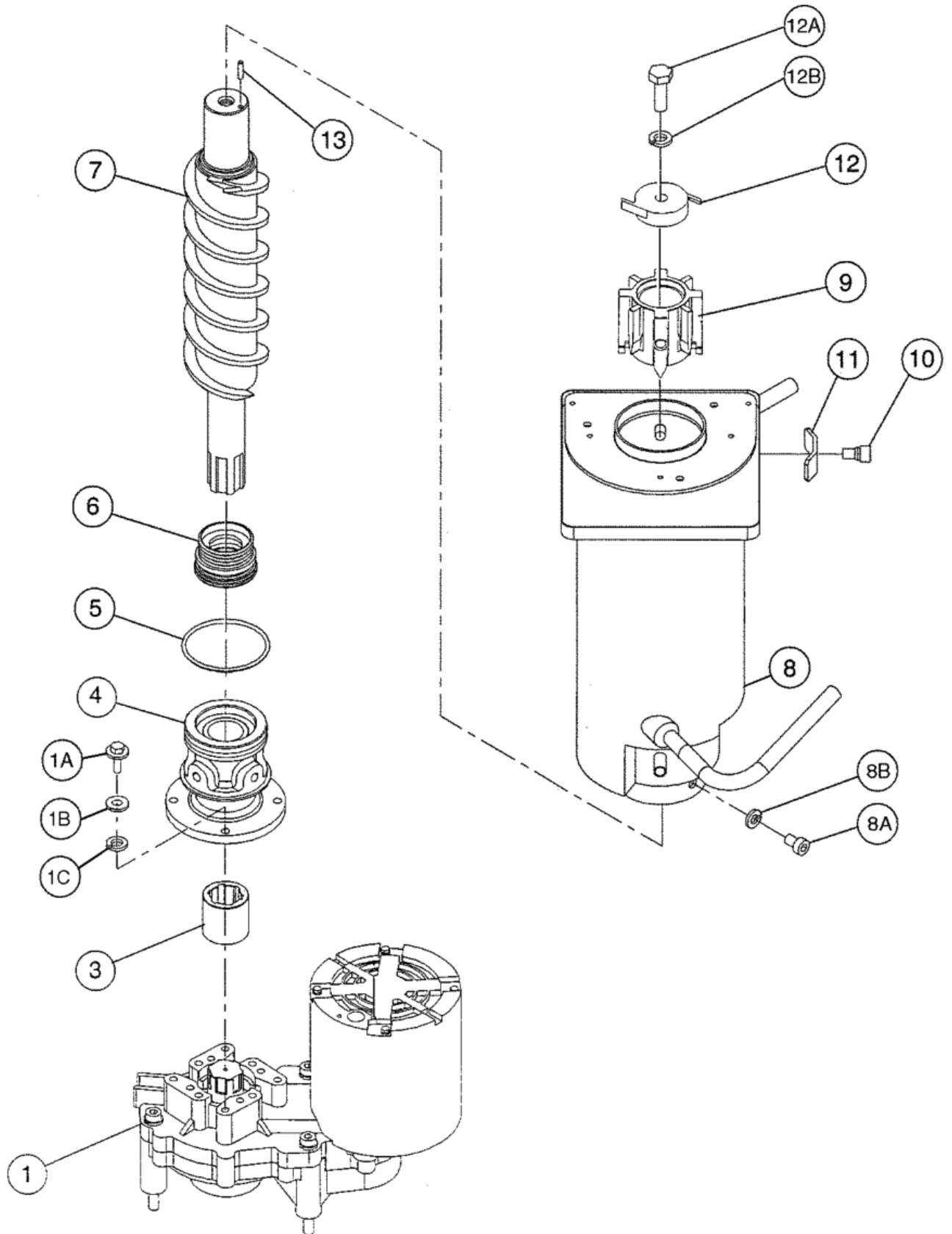

MODEL: F-800MAF-C				TITLE: B. ICE MAKING UNIT				
INDEX NO.	DESCRIPTION	MATERIAL OR MODEL NUMBER	PART NUMBER	REQUIRED NUMBER				
				H-0 J-0	K-1	K-2	L-0	
1	GEAR MOTOR	-	4A1296-01	1	x1			
		-	4A2194-01		o1	1	1	
1A	BOLT	6X20	458660-01	4	4	4	4	
1B	PLAIN WASHER	6.4X12.5X1.6, SS	7W22-0616	4	4	4	4	
1C	SPRING WASHER	6, SS	7L22-0600	4	4	4	4	
2	-	-	-					
3	COUPLING - SPLINE	SS	4A1297-01	1	1	1	1	
4	HOUSING	BRASS	2A0947G01	1	1	1	1	
5	"O" RING	G65	7616-G065	1	1	1	1	
6	MECHANICAL SEAL	HK9A-MN	432492-01	1	1	1	1	
7	AUGER	SS	2A0960G02	1	1	x1		
		SS	2A0932G02			o1	1	
8	EVAPORATOR	-	2A1227G01	1	1	1	1	
8A	SOCKET HEAD CAP SCREW	8X12, SS	7S12-0812	4	4	4	4	
8B	SPLIT LOCK WASHER	8, SS	7L22-0800	4	4	4	4	
9	EXTRUDING HEAD / 70N	SS	216531G01	1	1	1	1	
10	SOCKET HEAD CAP SCREW	SS, M10X15	429121-01	4	4	4	4	
11	WASHER	SS	427184-01	4	4	4	4	
12	CUTTER	SS	327145-01	1	1	1	1	
12A	HEX HEAD BOLT	10X30, SS	7B02-1030	1	1	1	1	
12B	SPLIT LOCK WASHER	10, SS	7L22-1000	1	1	1	1	
13	DOWEL PIN	SS, 4 x 16	713S-0416	1	1	1	1	

MODEL: F-800MWF-C			TITLE: B. ICE MAKING UNIT			
INDEX NO.	DESCRIPTION	MATERIAL OR MODEL NUMBER	PART NUMBER	REQUIRED NUMBER		
				H-0 J-0	K-0	K-1
1	GEAR MOTOR	-	4A1296-01	1	x1	
		-	4A2194-01		o1	1
1A	BOLT	6X20	458660-01	4	4	4
1B	PLAIN WASHER	6.4X12.5X1.6, SS	7W22-0616	4	4	4
1C	SPRING WASHER	6, SS	7L22-0600	4	4	4
2	-	-	-			
3	COUPLING - SPLINE	SS	4A1297-01	1	1	1
4	HOUSING	BRASS	2A0947G01	1	1	1
5	"O" RING	G65	7616-G065	1	1	1
6	MECHANICAL SEAL	HK9A-MN	432492-01	1	1	1
7	AUGER	SS	2A0960G02	1	1	x1
		SS	2A0932G02			o1
8	EVAPORATOR	-	2A1227G01	1	1	1
8A	SOCKET HEAD CAP SCREW	8X12, SS	7S12-0812	4	4	4
8B	SPLIT LOCK WASHER	8, SS	7L22-0800	4	4	4
9	EXTRUDING HEAD / 70N	SS	216531G01	1	1	1
10	SOCKET HEAD CAP SCREW	SS, M10X15	429121-01	4	4	4
11	WASHER	SS	427184-01	4	4	4
12	CUTTER	SS	327145-01	1	1	1
12A	HEX HEAD BOLT	10X30, SS	7B02-1030	1	1	1
12B	SPLIT LOCK WASHER	10, SS	7L22-1000	1	1	1
13	DOWEL PIN	SS, 4 x 16	713S-0416	1	1	1

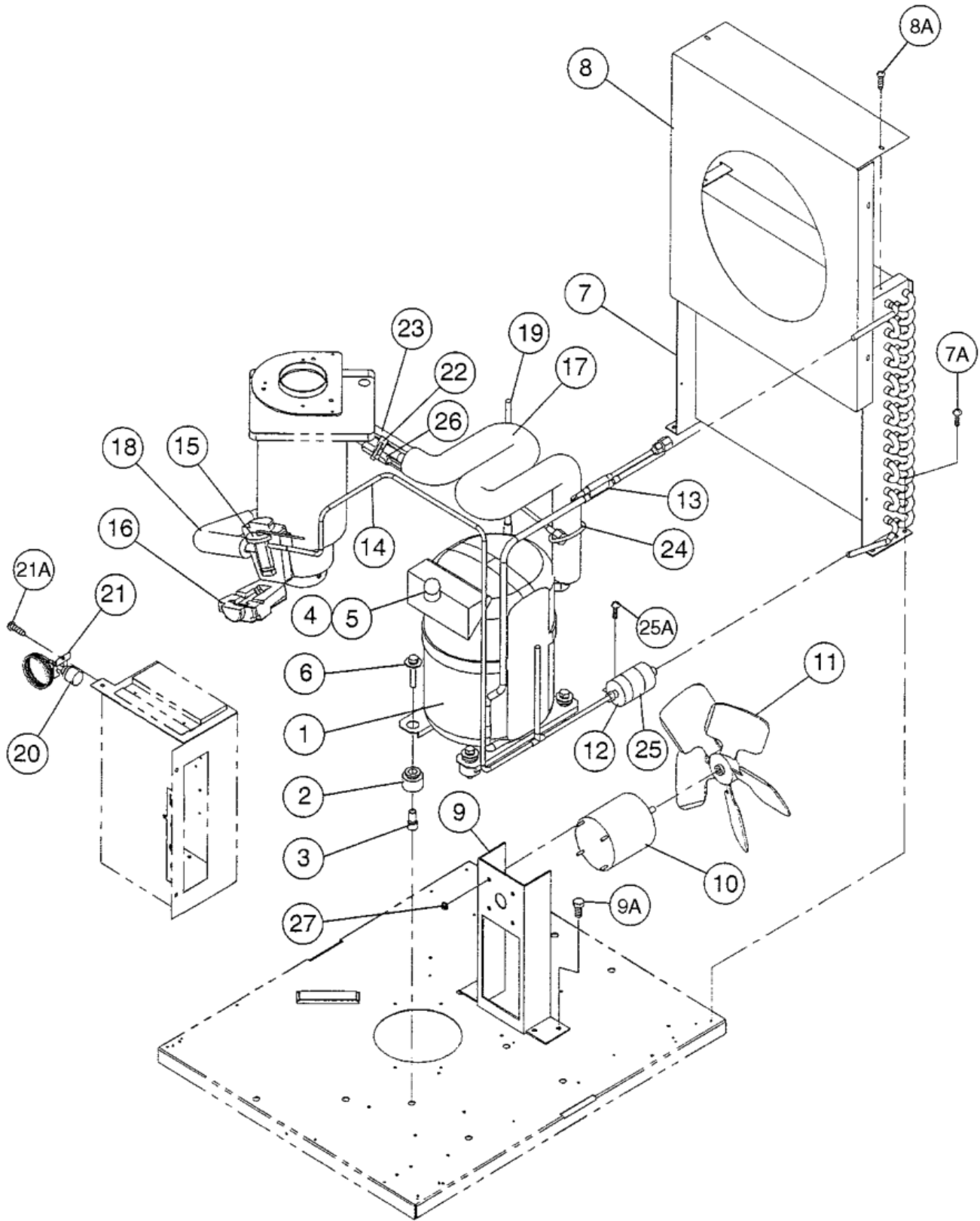

MODEL: F-800MAF(-C) TITLE: C. REFRIGERATION UNIT								
INDEX NO.	DESCRIPTION	MATERIAL OR MODEL NUMBER	PART NUMBER	REQUIRED NUMBER				
				H-0 J-0	K-0	K-1	K-2	L-0
1	COMPRESSOR	RS550IE-PAA	4A1387-01	1	x1			
		RS55-C2E-CAA	4A1843-01		o1	1	1	1
2	GROMMET	027-0073-00	434403-01	4	4	4	4	4
3	SPACER	027-0072-02	434404-01	4	4	4	4	4
4	PROTECTOR	-	4A1877-01	1	1	1	1	1
5	PROTECTOR HOLDER	-	4A1843F04	1	1	1	1	1
6	BOLT	8X50	437889-01	4	4	4	4	4
7	CONDENSER-AIR COOLED	971634C	2A0340-01	1	1	1	1	1
7A	FT SCREW	4X8, SS	7F32-0408	4	4	4	4	4
8	SHROUD	GS	2A0334-01	1	1	1	1	1
8A	T2 SCREW	4X8	7P31-0408	6	6	6	6	6
9	FAN MOTOR BRACKET	GS	327180-01	1	1	1	1	1
9A	HEX HEAD BOLT W/WASHER	5X12, SS	7B0230512	4	4	4	4	4
10	FAN MOTOR	U90B17190-1031	440911-01	1	1	1	1	1
11	FAN BLADE	AD10CW32	444898-01	1	1	1	1	1
12	DRIER	ATCH-032S	4A1113-01	1	1	1	1	1
13	COPPER TUBE (A) - HIGH SIDE	COPPER	3A0945G01	1	1	1	1	1
14	COPPER TUBE (B) -HIGH SIDE	COPPER	3A0946G01	1	1	1	1	1
15	EXPANSION VALVE	AN-1-SC	4A1117-01	1	1	1	1	1
16	EXPANSION VALVE COVER	PE FOAM	4A1168-01	1	1	1	1	1
17	COPPER TUBE – LOW SIDE	COPPER	3A1820G01	1	1	1	1	1
18	INSULATION TUBE	L=170	7762-1330	1	1	1	1	1
19	COPPER TUBE-ACCESS VALVE	COPPER	4A1364G01	1	1	1	1	1
20	PRESSURE SWITCH	ACB-2UB04	433441-05	1	1	1	1	1
21	PRESSURE SWITCH BRACKET	GS	434938-01	1	1	1	1	1
21A	T2 SCREW	4X8	7P31-0408	1	1	1	1	1
22	CLAMP	-	443461-01	1	1	1	1	1
23	INSULATION TUBE	L=130	7762-2943	1	1	1	1	1
24	CABLE TIE	CV-150	7920-0003	10	10	10	10	10

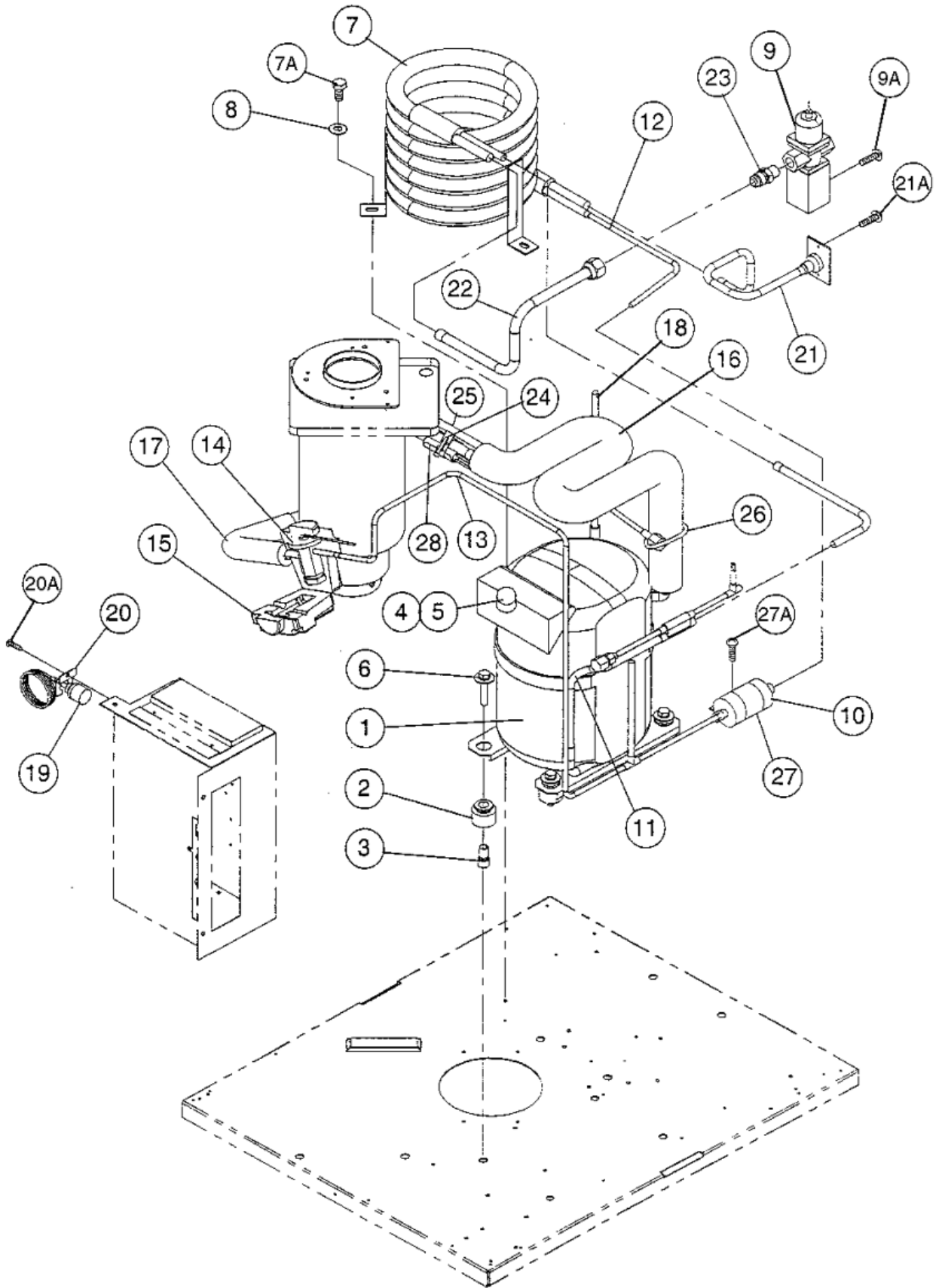

MODEL: F-800MWF(-C) TITLE: C. REFRIGERATION UNIT								
INDEX NO.	DESCRIPTION	MATERIAL OR MODEL NUMBER	PART NUMBER	REQUIRED NUMBER				
				H-0 J-0	K-0	K-1	K-2	L-0
1	COMPRESSOR	RS55CIE-PAA	4A1387-01	1	x1			
		R5S55C2E-CAA	4A1843-01		o1	1	1	1
2	GROMMET	027-0073-00	434403-01	4	4	4	4	4
3	SPACER	027-0072-02	434404-01	4	4	4	4	4
4	PROTECTOR	-	4A1877-01	1	1	1	1	1
5	PROTECTOR HOLDER	-	4A1843F04	1	1	1	1	1
6	BOLT	8X50	437889-01	4	4	4	4	4
7	CONDENSER-WATER COOLED	-	212929-04	1	1	1	1	1
7A	HEX BOLT W/WASHER (LF)	5X10, SS	7B0230510	3	3	3	3	3
8	WASHER	-	4A0655-03	3	3	3	3	3
9	WATER REGULATOR	V46EA-7	4A0911-04	1	1	1	1	1
9A	TRUSS HEAD SCREW	4X8	7C31-0408	2	2	2	2	2
10	DRIER	ATCH-032S	4A1113-01	1	1	1	1	1
11	COPPER TUBE (A) - HIGH SIDE	COPPER	3A0958G01	1	1	1	1	1
12	COPPER TUBE (B) - HIGH SIDE	COPPER	3A0946G01	1	1	1	1	1
13	COPPER TUBE (C) - HIGH SIDE	COPPER	3A0959-01	1	1	1	1	1
14	EXPANSION VALVE	AN-1-SC	4A1117-01	1	1	1	1	1
15	EXPANSION VALVE COVER	PE FOAM	4A1168-01	1	1	1	1	1
16	COPPER TUBE – LOW SIDE	COPPER	3A1820G01	1	1	1	1	1
17	INSULATION TUBE	L=170	7762-1330	1	1	1	1	1
18	COPPER TUBE - ACCESS VALVE	COPPER	4A1364G01	1	1	1	1	1
19	PRESSURE SWITCH	ACB-2UB04	433441-05	1	1	1	1	1
20	PRESSURE SWITCH BRACKET	GS	434938-01	1	1	1	1	1
20A	T2 SCREW	4X8	7P31-0408	1	1	1	1	1
21	COPPER TUBE (A) -WATER INLET	COPPER	3A0960G01	1	1	1	1	1
21A	T2 SCREW	4X8	7P31-0408	2	2	2	2	2
22	COPPER TUBE (B) -WATER OUTLET	COPPER	3A0961G01	1	1	1	1	1
23	MALE CONNECTOR	48F-8-6	4A1087-01	1	1	1	1	1
24	CLAMP	08	443461-01	1	1	1	1	1

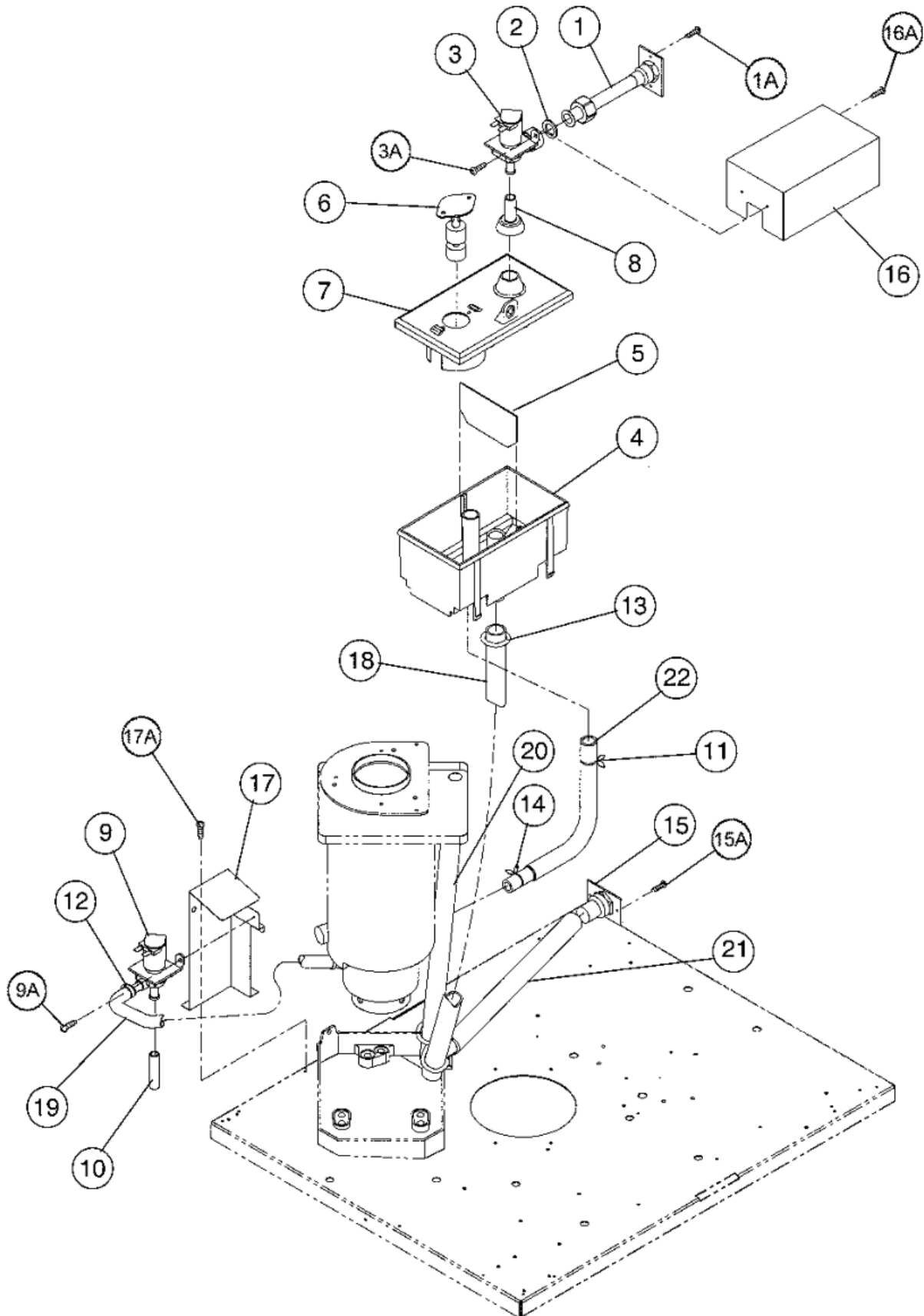

MODEL: F-800MAF(-C), MWF(-C)		TITLE: D. WATER CIRCUIT						
INDEX NO.	DESCRIPTION	MATERIAL OR MODEL NUMBER	PART NUMBER	REQUIRED NUMBER				
				H-0 J-0	K-0	K-1	K-2	L-0
1	WATER SUPPLY PIPE	COPPER	4A0891G01	1	1	1	1	1
1A	T2 SCREW	4X8	7P31-0408	2	2	2	2	2
2	WASHER	K-59963	4A0867-01	1	1	1	1	1
3	WATER VALVE	S-30	4A0865-01	1	1	1	1	1
3A	T2 SCREW	4X8, SS	7P32-0408	2	2	2	2	2
4	RESERVOIR	PP	2A0753-01	1	1	1	1	1
5	SEPARATOR-RESERVOIR	ABS	4A1255-01	1	1	1	1	1
6	FLOAT SWITCH	TW-1221-101	435490-01	1	1	1	1	1
7	RESERVOIR COVER	PP	214810-01	1	1	1	1	1
8	INLET- RESERVOIR	SI.R.	4A0869-01	1	1	1	1	1
9	WATER VALVE	S-60N	4A0866-01	1	x1			
		-	4A2077-01		o1	1	1	1
9A	T2 SCREW	4X8	7P31-0408	2	2	2	2	2
10	VINYL HOSE	L=50	7725-0912	1	x1			
		L=40	7716-0913		o1	1	1	1
11	CLAMP	-	435934-06	1	-			
12	CLAMP	-	421642-04	2	-			
13	CABLE TIE	CV-150	7920-0003	8	4	4	4	4
14	HOSE CLAMP	-	4A2017-06	1	1	1	1	1
15	FITTING	COPPER	4A0776G01	1	1	1	1	1
15A	T2 SCREW	4X8	7P31-0406	2	2	2	2	2
16	WATER VALVE BRACKET	GS	3A0553-01	1	1	1	1	1
16A	T2 SCREW	4X8	7P31-0408	3	3	3	3	3
17	WATER VALVE BRACKET (D)	GS	3A0554-01	1	1	1	1	1
17A	T2 SCREW	4X8	7P31-0408	2	2	2	2	2
18	SILICONE HOSE	L=410	7730-1822	1	1	1	1	1
19	SILICONE HOSE	L=225	7730-0912	1	x1			
		L=225	7730I3896		o1	1	1	1

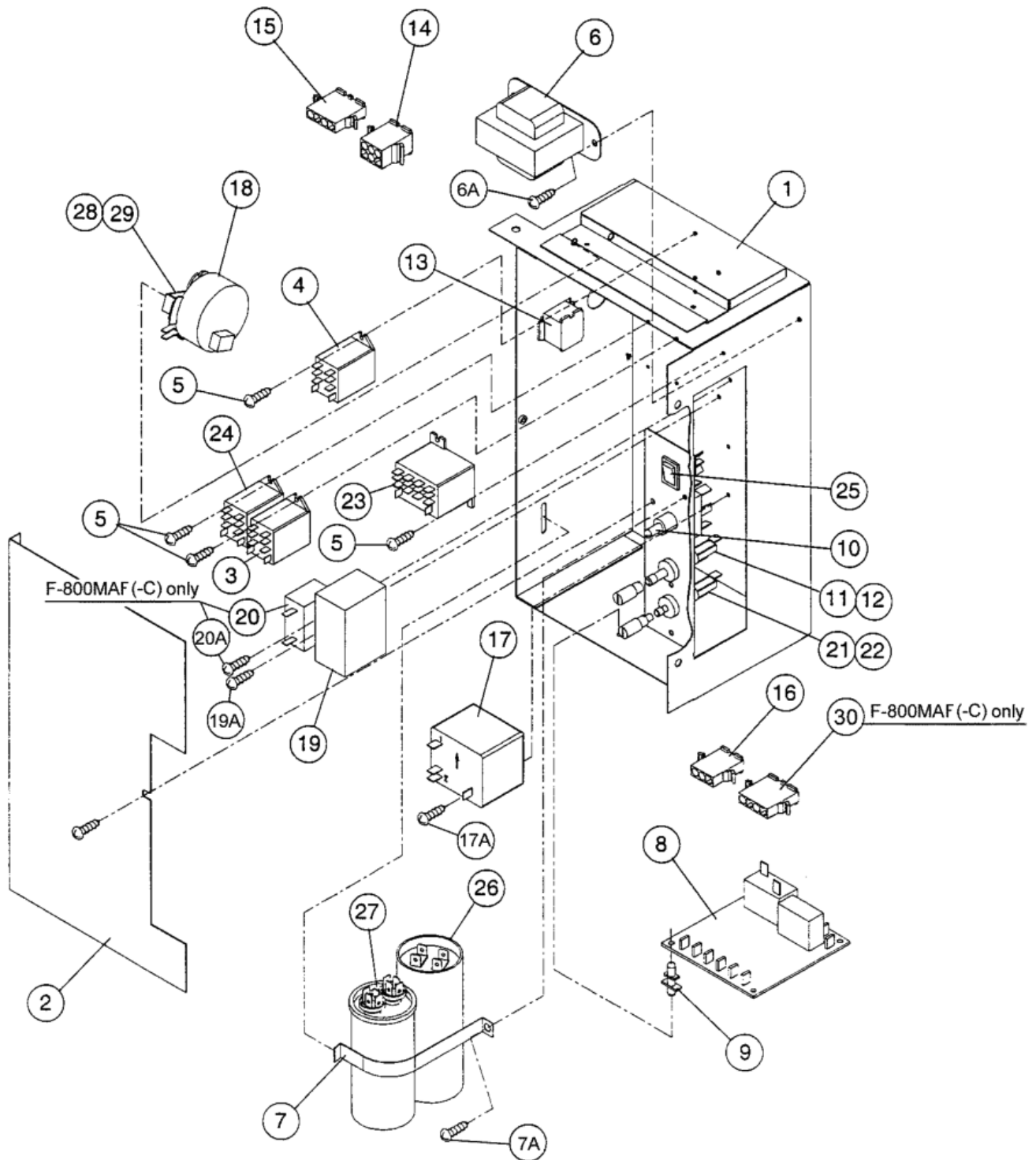

MODEL: F-800MAF(-C), MWF(-C) TITLE: E. CONTROL BOX ASSEMBLY								
INDEX NO.	DESCRIPTION	MATERIAL OR MODEL NUMBER	PART NUMBER	REQUIRED NUMBER				
				H-0 J-0	K-0	K-1	K-2	L-0
1	CONTROL BOX	GS	2A0229G04	1	1	1	1	1
2	COVER-CONTROL BOX	GS	3A0411-01	1	1	1	1	1
2A	TRUSS HEAD SCREW	4X8	7C31-0408	1	1	1	1	1
3	RELAY	LY-1F, AC120V	418271-03	1	1	1	1	1
4	RELAY	LY-2F, AC24V	406132-03	1	1	1	1	1
5	TAPPING SCREW	3X8	431415-01	8	8	8	8	8
6	TRANSFORMER	BE1416225GEK 120/24V, 1A	4A0557-01	1	1	1	1	1
6A	T2 SCREW	4X8	7P31-0408	2	2	2	2	2
7	STRAP	GS	434580-01	1	x1			
		GS	434580-05		o1	1	1	1
7A	T2 SCREW	4X8	7P31-0408	2	2	2	2	2
8	TIMER BOARD	H2AA144C01	437305-01	1	1	1	1	1
9	BOARD SUPPORT	CBLS37-N	4A0336-03	4	4	4	4	4
10	TOGGLE SWITCH	-	4A0567-01	1	1	1	1	x1
		-	4A2332-01					o1
11	FUSE HOLDER	HTB921, 250V, 1A	4A0892-01	1	1	1	1	1
12	FUSE	AGC-1, 250V, 1A	4A0893-01	1	1	1	1	1
13	9P PLUG HOUSING	3191-09P	412832-02	1	1	1	1	1
14	6P PLUG HOUSING	3191-06P	412832-03	1	1	1	1	1
15	4P PLUG HOUSING	3191-04P	412832-05	1	1	1	1	1
16	3P PLUG HOUSING	3191-03P	412832-06	1	1	1	1	1
17	STARTER	-	4A0875-01	1	1	1	1	x1
		-	4A1107-13					o1
17A	T2 SCREW	4X8	7P31-0408	1	1	1	1	1
18	TIMER	9816-2	4A0889-01	1	1	1	1	1
19	CAPACITOR (GM)	12FD, 330VAC	4A0894-01	1	1	1	1	1
19A	T2 SCREW	4X8	7P31-0408	1	1	1	1	1

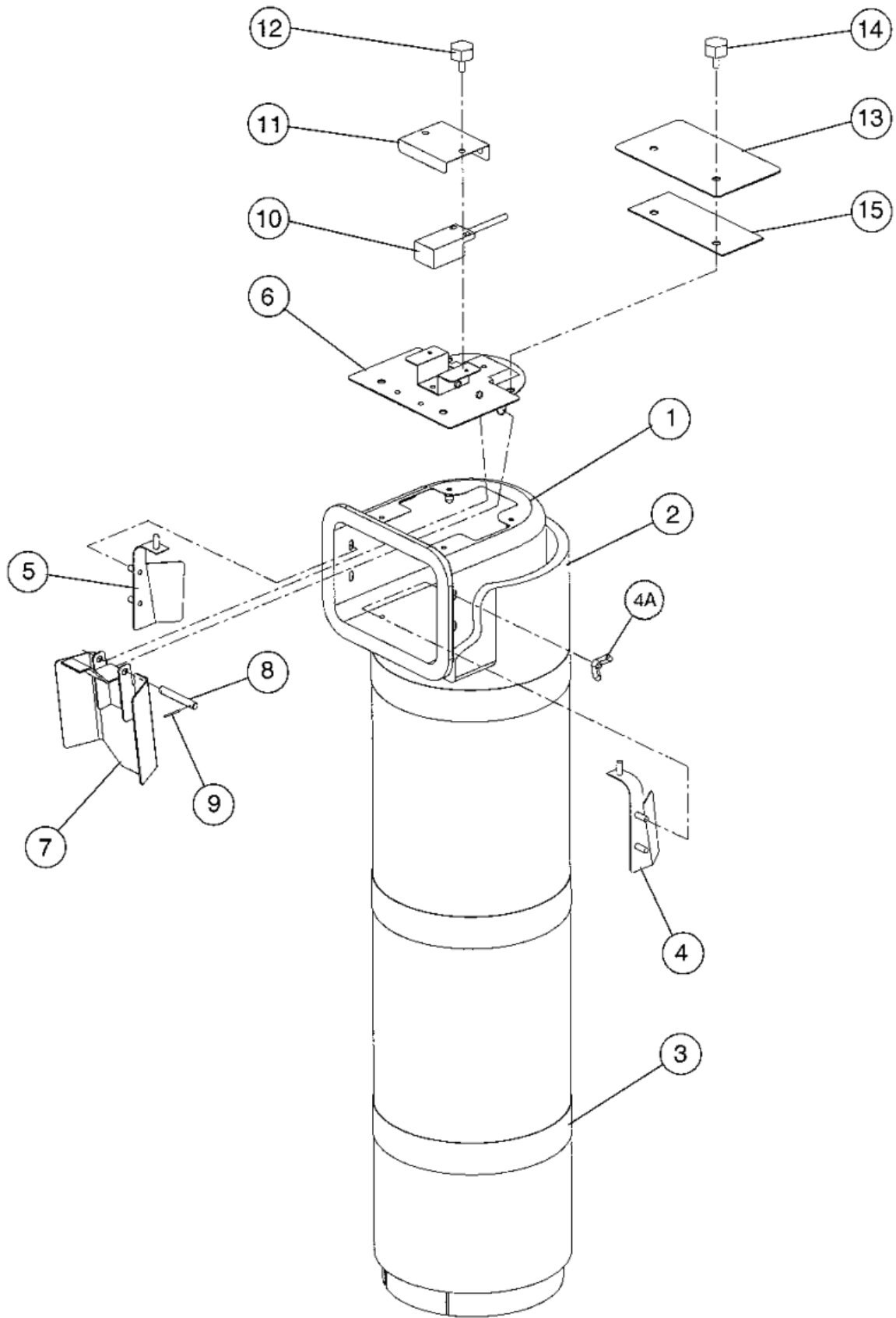

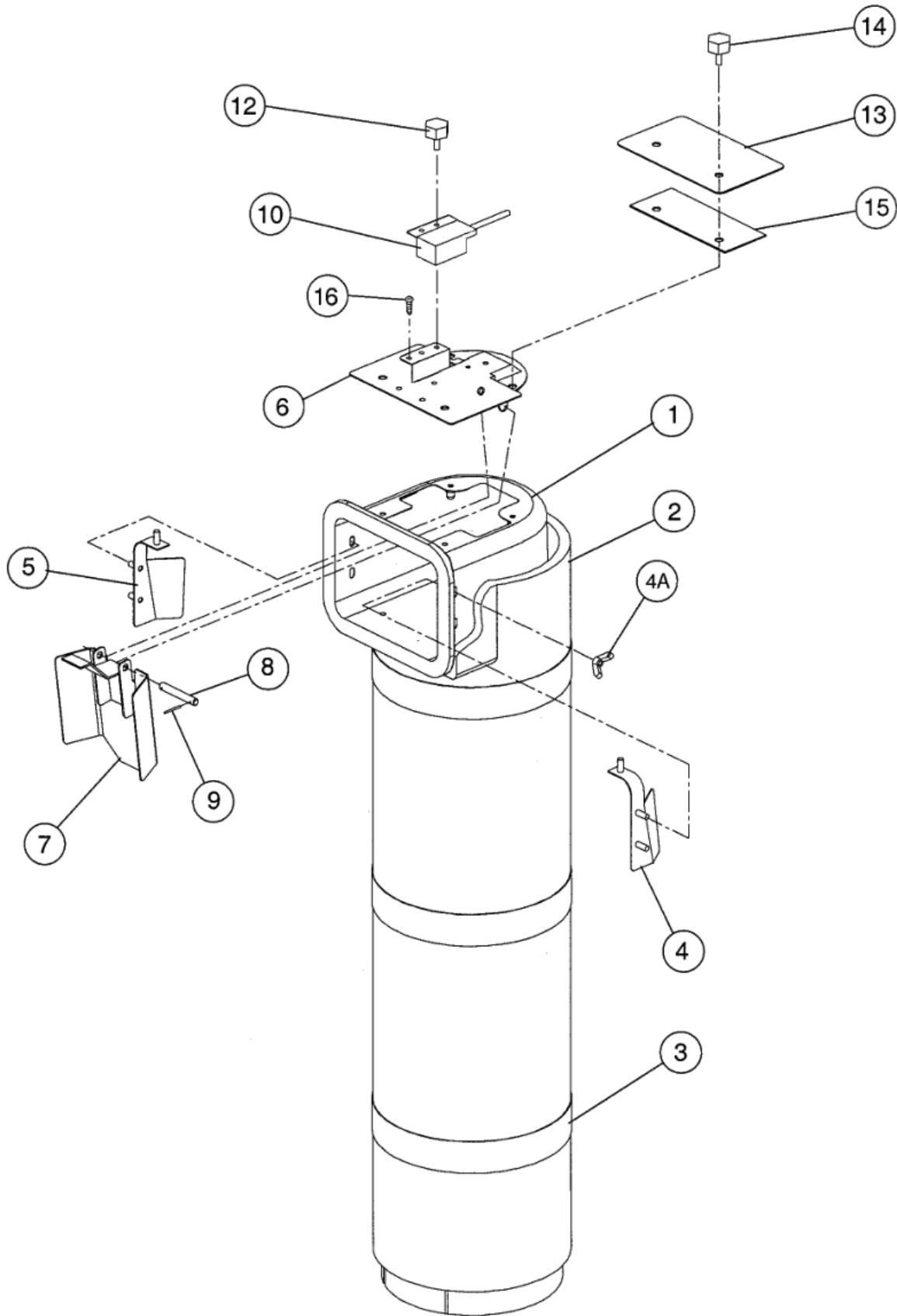

MODEL: F-800MAF(-C), MWF(-C)		TITLE: F. CHUTE ASSEMBLY						
INDEX NO.	DESCRIPTION	MATERIAL OR MODEL NUMBER	PART NUMBER	REQUIRED NUMBER				
				H-0 J-0	K-0	K-1	K-2	L-0
1	CHUTE	PE	2A1057-01	1	1	1	1	1
2	INSULATION-CHUTE	PE FOAM	213304-02	1	1	1	1	1
3	TIE	PA	436531G01	3	3	3	3	3
4	BAFFLE-CHUTE (A)	SS	3A0400G01	1	1	1	1	1
4A	WING NUT	4, SS	7E12-0400	6	6	6	6	6
5	BAFFLE-CHUTE (B)	SS	3A0399G01	1	1	1	1	1
6	BIN CONTROL	SS	338043G02	1	-			
	BIN CONTROL ASSEMBLY	SS	3A1744G01		1	1	1	1
7	ACTUATOR	SS	436848G01	1	1	1	1	1
8	SHAFT	SS	436851-01	1	1	1	1	1
9	SNAP PIN	SS, SSP-5	715S-0005	2	2	2	2	2
10	PROXIMITY SWITCH	-	427223-01	1	-			
			4A2033-01		1	1	1	1
11	COVER – SWITCH	SS	451870-01	1	-			
12	THUMBSCREW	ABS,SS	415949G04	2	2	2	2	2
13	PLATE	SS	438336-01	1	-			
		SS	4A2039-01		1	1	1	1
14	THUMBSCREW	ABS,SS	415949G09	2	2	2	2	2
15	PACKING	EPDM	441217-01	1	1	1	1	1
16	TRUSS HEAD SCREW	4X8, SS	7C32-0408		1	1	1	1

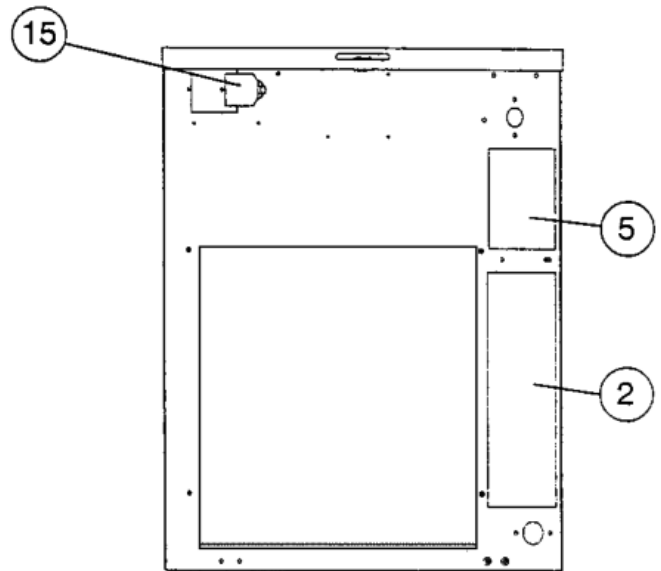
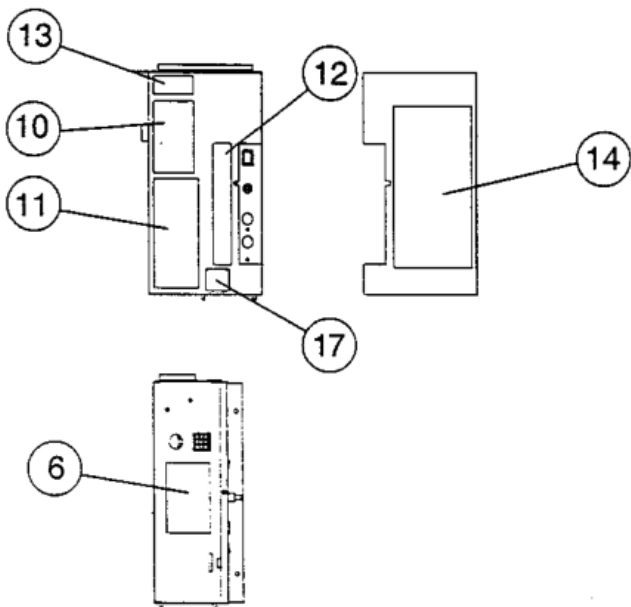
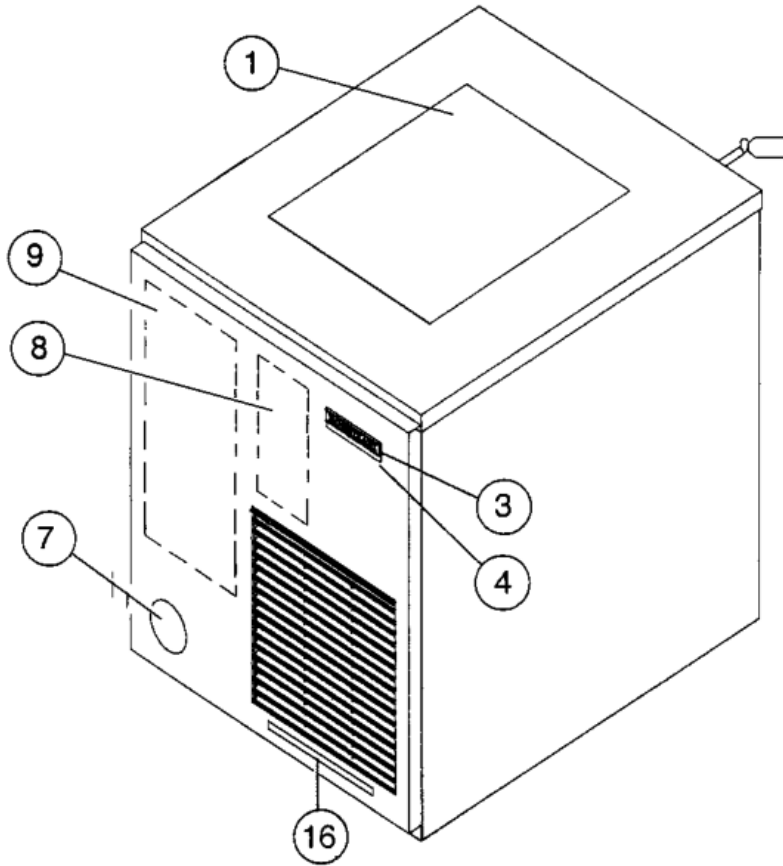

MODEL: F-800MAF		TITLE: G. LABEL LOCATION						
INDEX NO.	DESCRIPTION	MATERIAL OR MODEL NUMBER	PART NUMBER	REQUIRED NUMBER				
				H-0 J-0	K-0	K-1	L-0	
1	INSTRUCTION SHEET	PAPER	2A1054-01	1	1	1	1	
2	INSTRUCTION SHEET	PAPER	433523-01	1	1	1	1	
3	EMBLEM	PETP FILM	4A0560-01	1	1	1	1	
4	MODEL NUMBER LABEL	PETP FILM	4A1832-01	1	1	1	1	
5	NAMEPLATE	PES FILM	3A0971-01	1	1	1	1	
6	RATING LABEL	PES FILM	3A1123-01	1	1	1	1	
7	LABEL-PENGUIN-HA-R	PETP FILM	4A0526-01	1	1	1	1	
8	INSTRUCTION LABEL	PVC FILM	326371-01	1	1	1	1	
9	LABEL-CLEANING	PVC FILM	326370-01	1	1	1	1	
10	CAUTION LABEL (E)	PVC FILM	439145-01	1	1	1	1	
11	CAUTION LABEL (H)	PVC FILM	439148-01	1	1	1	1	
12	CONTROL LABEL	PVC FILM	4A1613-01	1	1	1	1	
13	LABEL-R404A	-	4A0960-01	1	1	1	1	
14	WIRING LABEL	PVC FILM	2A1395-01	1	x1			
		PVC FILM	2A1703-01		o1	1	1	
15	TAG-WARNING: ELECTRICAL CONNECTION	PAPER	435005-01	1	1	1	1	
16	LABEL-AIR FILTER	PETP FILM	426177-01	1	1	1	1	
17	LABEL (GM) - FUSE	PVC FILM	4A1614-01	1	1	1	1	

MODEL: F-800MAF-C		TITLE: G. LABEL LOCATION						
INDEX NO.	DESCRIPTION	MATERIAL OR MODEL NUMBER	PART NUMBER	REQUIRED NUMBER				
				H-0 J-0	K-1	K-2	L-0	
1	INSTRUCTION SHEET	PAPER	2A1054-01	1	1	1	1	
2	INSTRUCTION SHEET	PAPER	433523-01	1	1	1	1	
3	EMBLEM	PETP FILM	4A0560-01	1	1	1	1	
4	MODEL NUMBER LABEL	PETP FILM	4A1832-03	1	1	1	1	
5	NAMEPLATE	PES FILM	3A0971-03	1	1	1	1	
6	RATING LABEL	PES FILM	3A1123-03	1	1	1	1	
7	LABEL-PENGUIN-HA-R	PETP FILM	4A0526-01	1	1	1	1	
8	INSTRUCTION LABEL	PVC FILM	326371-01	1	1	1	1	
9	LABEL-CLEANING	PVC FILM	326370-01	1	1	1	1	
10	CAUTION LABEL (E)	PVC FILM	439145-01	1	1	1	1	
11	CAUTION LABEL (H)	PVC FILM	439148-01	1	1	1	1	
12	CONTROL LABEL	PVC FILM	4A1613-01	1	1	1	1	
13	LABEL-R404A	-	4A0960-01	1	1	1	1	
14	WIRING LABEL	PVC FILM	2A1395-01	1	x1			
		PVC FILM	2A1703-01		o1	1	1	
15	TAG-WARNING: ELECTRICAL CONNECTION	PAPER	435005-01	1	1	1	1	
16	LABEL-AIR FILTER	PETP FILM	426177-01	1	1	1	1	
17	LABEL (GM) - FUSE	PVC FILM	4A1614-01	1	1	1	1	

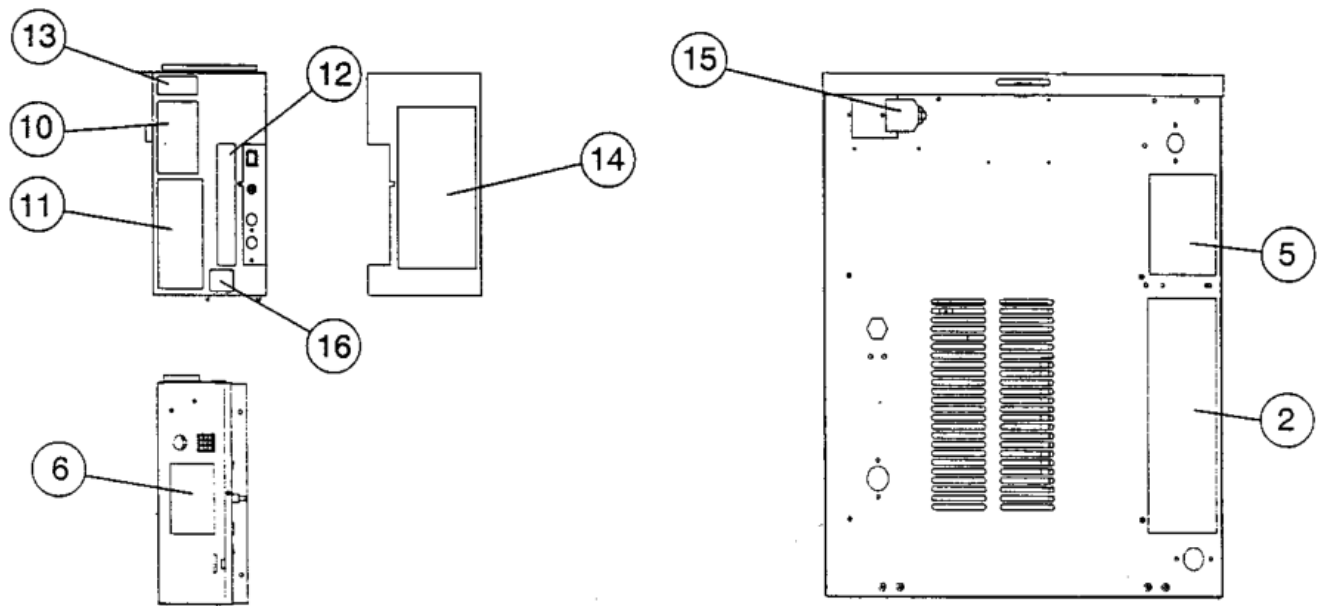
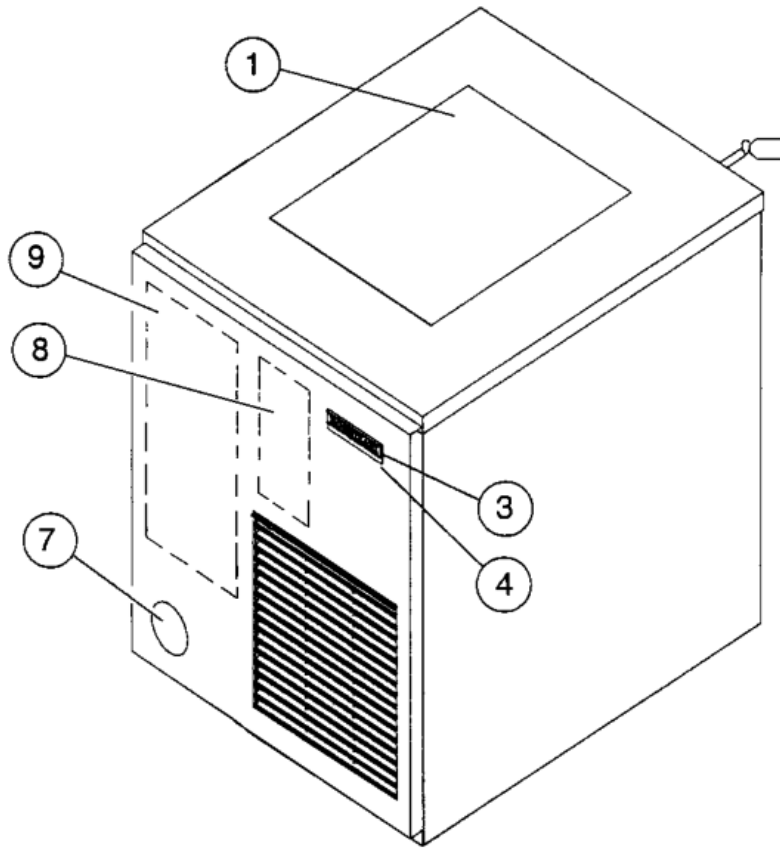

MODEL: F-800MWF		TITLE: G. LABEL LOCATION						
INDEX NO.	DESCRIPTION	MATERIAL OR MODEL NUMBER	PART NUMBER	REQUIRED NUMBER				
				H-0 J-0	K-1	K-2	L-0	
1	INSTRUCTION SHEET	PAPER	2A1054-01	1	1	1	1	
2	INSTRUCTION SHEET	PAPER	433523-01	1	1	1	1	
3	EMBLEM	PETP FILM	4A0560-01	1	1	1	1	
4	MODEL NUMBER LABEL	PETP FILM	4A1832-02	1	1	1	1	
5	NAMEPLATE	-	3A0971-02	1	-			
		-	3A0971-05		1	1	1	
6	RATING LABEL	-	3A1123-02	1	-			
		-	3A1123-05		1	1	1	
7	LABEL-PENGUIN-HA-R	PETP FILM	4A0526-01	1	1	1	1	
8	INSTRUCTION LABEL	PVC FILM	326371-01	1	1	1	1	
9	LABEL-CLEANING	PVC FILM	326370-01	1	1	1	1	
10	CAUTION LABEL (E)	PVC FILM	439145-01	1	1	1	1	
11	CAUTION LABEL (H)	PVC FILM	439148-01	1	1	1	1	
12	CONTROL LABEL	PVC FILM	4A1613-01	1	1	1	1	
13	LABEL-R404A	PES FILM	4A0960-01	1	1	1	1	
14	WIRING LABEL	PVC FILM	2A1395-01	1	x1			
		PVC FILM	2A1703-01		o1	1	1	
15	TAG-WARNING: ELECTRICAL CONNECTION	PAPER	435005-01	1	1	1	1	
16	LABEL (GM) - FUSE	PVC FILM	4A1614-01	1	1	1	1	

MODEL: F-800MWF-C		TITLE: G. LABEL LOCATION					
INDEX NO.	DESCRIPTION	MATERIAL OR MODEL NUMBER	PART NUMBER	REQUIRED NUMBER			
				H-0 J-0	K-0	K-1	
1	INSTRUCTION SHEET	PAPER	2A1054-01	1	1	1	
2	INSTRUCTION SHEET	PAPER	433523-01	1	1	1	
3	EMBLEM	PETP FILM	4A0560-01	1	1	1	
4	MODEL NUMBER LABEL	PETP FILM	4A1832-04	1	1	1	
5	NAMEPLATE	-	3A0971-04	1	-		
		-	3A0971-06		1	1	
6	RATING LABEL	-	3A1123-04	1	-		
		-	3A1123-06		1	1	
7	LABEL-PENGUIN-HA-R	PETP FILM	4A0526-01	1	1	1	
8	INSTRUCTION LABEL	PVC FILM	326371-01	1	1	1	
9	LABEL-CLEANING	PVC FILM	326370-01	1	1	1	
10	CAUTION LABEL (E)	PVC FILM	439145-01	1	1	1	
11	CAUTION LABEL (H)	PVC FILM	439148-01	1	1	1	
12	CONTROL LABEL	PVC FILM	4A1613-01	1	1	1	
13	LABEL-R404A	PES FILM	4A0960-01	1	1	1	
14	WIRING LABEL	PVC FILM	2A1395-01	1	x1		
		PVC FILM	2A1703-01		o1	1	
15	TAG-WARNING: ELECTRICAL CONNECTION	PAPER	435005-01	1	1	1	
16	LABEL (GM) - FUSE	PVC FILM	4A1614-01	1	1	1	

