



HOSHIZAKI

Parts List

Modular Flaker

Models

F-801MAH(-C), MWH(-C)



hoshizakiamerica.com

Number: 71232
Issued: 7-29-2004
Revised: 10-20-2020

CONTENTS

Auxiliary Codes.....	3
Note About Ordering Parts	4
A. Main Assembly & Refrigeration Circuit	5
F-801MAH(-C)	5
F-801MWH(-C)	8
B. Icemaking Unit	11
C. Water Circuit.....	14
D. Control Box Assembly.....	17
E. Accessories & Labels	19

Auxiliary Codes

F-801MAH

N-0 November 2003
P-0 January 2004
P-1 June 2004
Q-0 December 2004
R-0 December 2005
S-0 January 2007
T-0 January 2008
T-1 September 2008
U-0 January 2009
V-0 January 2010
V-1 May 2010
V-2 June 2010
V-3 October 2010
V-4 November 2010
A-0 January 2011
B-0 January 2012
B-1 March 2012
B-2 December 2012
C-0 January 2013
C-1 June 2013
D-0 January 2014
D-2 October 2014
E-0 January 2015
F-0 January 2016

F-801MWH

P-0 January 2004
Q-0 December 2004
R-0 December 2005
S-0 January 2007
T-0 February 2008
T-1 September 2008
U-0 February 2009
U-0(J) September 2009
V-0 January 2010
V-2 May 2010
V-3 October 2010
V-4 November 2010
A-0 January 2011
B-0 January 2012
B-1 March 2012
B-2 December 2012
C-1 January 2013
C-2 June 2013
D-0 January 2014
D-1 March 2014
D-2 October 2014
E-0 January 2015
F-0 January 2016

F-801MAH-C

P-0 February 2004
P-1 June 2004
Q-0 December 2004
R-0 December 2005
S-0 January 2007
T-0 January 2008
T-1 September 2008
U-0 January 2009
V-0 January 2010
V-1 May 2010
V-2 June 2010
V-3 October 2010
V-4 November 2010
A-0 January 2011
B-0 January 2012
B-1 April 2012
B-2 December 2012
C-0 January 2013
C-1 June 2013
D-0 January 2014
D-2 October 2014
E-0 January 2015
F-0 January 2016

F-801MWH-C

P-0 March 2004
Q-0 December 2004
R-0 January 2006
S-0 January 2007
T-0 January 2008
T-1 September 2008
U-0 January 2009
U-0(J) September 2009
V-0 January 2010
V-2 May 2010
V-3 October 2010
V-4 November 2010
A-0 January 2011
B-0 January 2012
B-1 March 2012
B-2 December 2012
C-1 February 2013
C-2 June 2013
D-0 January 2014
D-1 March 2014
D-2 October 2014
E-0 January 2015
F-0 January 2016

Auxiliary Code Breakdown

The auxiliary code is the first two characters in the serial number. The first character indicates the year. Years progress or regress in alphabetical order. The series runs from "A" through "V" and the letters "I" and "O" are skipped. The second character indicates significant part changes within a year. Base is "0" and this number advances for each change. In cases where there is a letter in parentheses, this designates the month. This is the last character in the serial number. The series runs from "(A)" through "(M)" and the letter "(I)" is skipped. This designation is only included when identifying a parts change within an auxiliary code.

Note About Ordering Parts

Most assemblies cannot be ordered as complete units; parts in the assemblies generally must be ordered separately.

A. Main Assembly & Refrigeration Circuit
F-801MAH(-C)
 N-0 to F-0

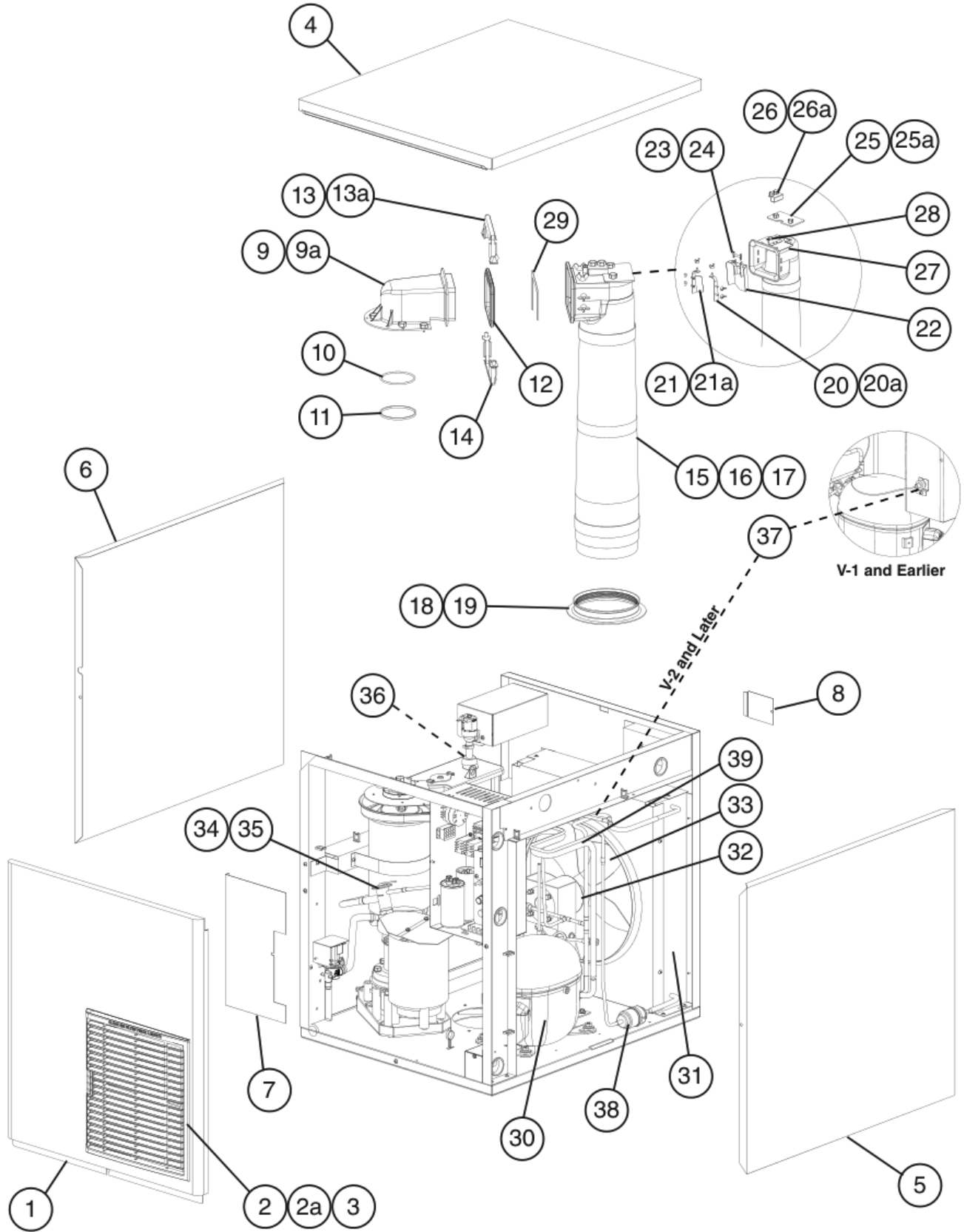

Title: A. Main Assembly & Refrigeration Circuit Model: F-801MAH(-C)

Index No.	Description	Material or Model Number	Part Number	Required Number							
				N-0 to V-1	V-2 to F-0						
Main Assembly											
1	Front Panel		2A2124-01	1	1						
2	Louver		1A0547-01	1	1						
2a	Push Retainer		4A2414-01	3	3						
3	Air Filter		2A2062G01	1	1						
4	Top Panel		2A2064-01	1	1						
5	Right Side Panel		2A2073G01	1	1						
6	Left Side Panel		2A2072G01	1	1						
7	Control Box Cover		3A0411-01	1	1						
8	Junction Box Cover		433410-01	1	1						
9	Spout		104797-01	1	1						
9a	Thumbscrew		415949G08	5	5						
10	O-Ring		4A4755-03	1	1						
11	Nylon Ring		432661-02	1	1						
12	Spout-to-Chute Packing		321037-01	1	1						
13	Upper Strap		328703-02	1	1						
13a	Wing Nut		7E12-0600	2	2						
14	Lower Strap		321038G02	1	1						
15	Chute		2A1919-01	1	1						
16	Chute Insulation		2A1920-01	1	1						
17	Chute Tie		436531G01	3	3						
18	Chute Packing		432877-01	1	1						
19	Ring		3A1017-01	1	1						
20	Chute Baffle A		3A0400G01	1	1						
20a	Wing Nut		7E12-0400	3	3						
21	Chute Baffle B		3A0399G01	1	1						
21a	Wing Nut		7E12-0400	3	3						
22	Actuator		436848G01	1	1						
23	Shaft		436851-01	1	1						
24	Snap Pin		715S-0005	2	2						
25	Plate		4A2039-01	1	1						
25a	Thumbscrew		415949G10	2	2						
26	Mechanical Bin Control (proximity switch)		4A2033-01	1	1						
26a	Thumbscrew		415949G08	2	2						
27	Mechanical Bin Control Bracket		3A1744G01	1	1						
28	Truss Head Screw (ground)		7C32-0408	1	1						
29	Spout-to-Chute Bracket		4A1712-01	1	1						

Title: A. Main Assembly & Refrigeration Circuit Model: F-801MAH(-C)											
Index No.	Description	Material or Model Number	Part Number	Required Number							
				N-0 to V-1	V-2 to F-0						
Refrigeration Circuit											
30	Compressor	SB12-0004R1 - Must order new start components	4A1276-40	1	-						
			4A4479-01		1						
31	Condenser		211663-02	1	1						
32	Fan Motor		4A3158-01	1	1						
33	Fan Blade		4A0197-01	1	1						
34	Thermostatic Expansion Valve		4A1117-01	1	1						
35	Thermostatic Expansion Valve Cover		4A1168-01	1	1						
36	Thermostatic Expansion Valve Bulb Holder		3A0112-01	1	1						
37	High-Pressure Switch		433441-05	1	-						
			463180-05		1						
38	Drier		4A1113-01	1	1						
39	Heat Exchanger		3A3111G01	1	-						
			3A5889G01		1						

A. Main Assembly & Refrigeration Circuit
F-801MWH(-C)
 N-0 to F-0

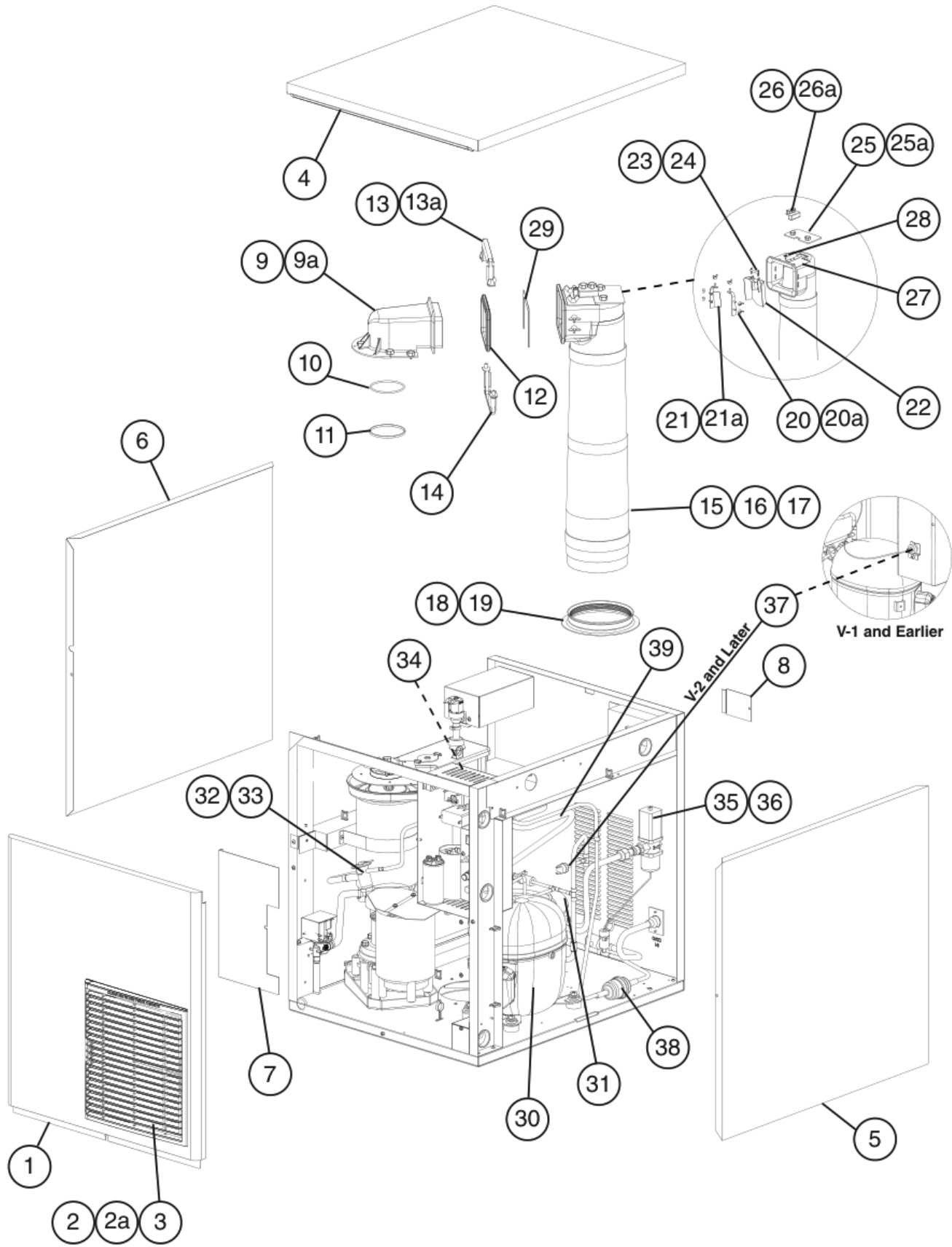

Title: A. Main Assembly & Refrigeration Circuit Model: F-801MWH(-C)										
Index No.	Description	Material or Model Number	Part Number	Required Number						
				N-0 to U-0 (H)	U-0 (J) to V-1	V-2 to B-2	C-1 to D-0	D-1 to F-0		
Main Assembly										
1	Front Panel		2A2124-01	1	1	1	1	1		
2	Louver		1A0547-01	1	1	1	1	1		
2a	Push Retainer		4A2414-01	3	3	3	3	3		
3	Air Filter		2A2062G01	1	1	1	1	1		
4	Top Panel		2A2064-01	1	1	1	1	1		
5	Right Side Panel		2A2073G01	1	1	1	1	1		
6	Left Side Panel		2A2072G01	1	1	1	1	1		
7	Control Box Cover		3A0411-01	1	1	1	1	1		
8	Junction Box Cover		433410-01	1	1	1	1	1		
9	Spout		104797-01	1	1	1	1	1		
9a	Thumbscrew		415949G08	5	5	5	5	5		
10	O-Ring		4A4755-03	1	1	1	1	1		
11	Nylon Ring		432661-02	1	1	1	1	1		
12	Spout-to-Chute Packing		321037-01	1	1	1	1	1		
13	Upper Strap		328703-02	1	1	1	1	1		
13a	Wing Nut		7E12-0600	2	2	2	2	2		
14	Lower Strap		321038G02	1	1	1	1	1		
15	Chute		2A1919-01	1	1	1	1	1		
16	Chute Insulation		2A1920-01	1	1	1	1	1		
17	Chute Tie		436531G01	3	3	3	3	3		
18	Chute Packing		432877-01	1	1	1	1	1		
19	Ring		3A1017-01	1	1	1	1	1		
20	Chute Baffle A		3A0400G01	1	1	1	1	1		
20a	Wing Nut		7E12-0400	3	3	3	3	3		
21	Chute Baffle B		3A0399G01	1	1	1	1	1		
21a	Wing Nut		7E12-0400	3	3	3	3	3		
22	Actuator		436848G01	1	1	1	1	1		
23	Shaft		436851-01	1	1	1	1	1		
24	Snap Pin		715S-0005	2	2	2	2	2		
25	Plate		4A2039-01	1	1	1	1	1		
25a	Thumbscrew		415949G10	2	2	2	2	2		
26	Mechanical Bin Control (proximity switch)		4A2033-01	1	1	1	1	1		
26a	Thumbscrew		415949G08	2	2	2	2	2		
27	Mechanical Bin Control Bracket		3A1744G01	1	1	1	1	1		
28	Truss Head Screw (Ground)		7C32-0408	1	1	1	1	1		
29	Spout-to-Chute Bracket		4A1712-01	1	1	1	1	1		

Title: A. Main Assembly & Refrigeration Circuit Model: F-801MWH(-C)

Index No.	Description	Material or Model Number	Part Number	Required Number									
				N-0 to U-0 (H)	U-0 (J) to V-1	V-2 to B-2	C-1 to D-0	D-1 to F-0					
Refrigeration Circuit													
30	Compressor	SB12-0004R1 - Must order new start components	4A1726-40	1	1	-							
			4A4479-01			1	1	1					
31	Condenser		2A2359G03	1	1	1	-						
			3A7323-01				1	-					
			3A7321-01						1				
32	Thermostatic Expansion Valve		4A1117-01	1	1	1	1	1					
33	Thermostatic Expansion Valve Cover		4A1168-01	1	1	1	1	1					
34	Thermostatic Expansion Valve Bulb Holder		3A0112-01	1	1	1	1	1					
35	Water Regulating Valve		4A0911-04	1	1	1	1	1					
36	Male Connector		4A1087-01	1	1	1	1	1					
37	High-Pressure Switch		433441-05	1	-								
			463180-05		1	1	1	1					
38	Drier		4A1113-01	1	1	1	1	1					
39	Heat Exchanger		3A3111G01	1	1	-							
			3A5889G01			1	1	1					

B. Icemaking Unit
F-801M_H(-C)
1/2
 N-0 to D-1

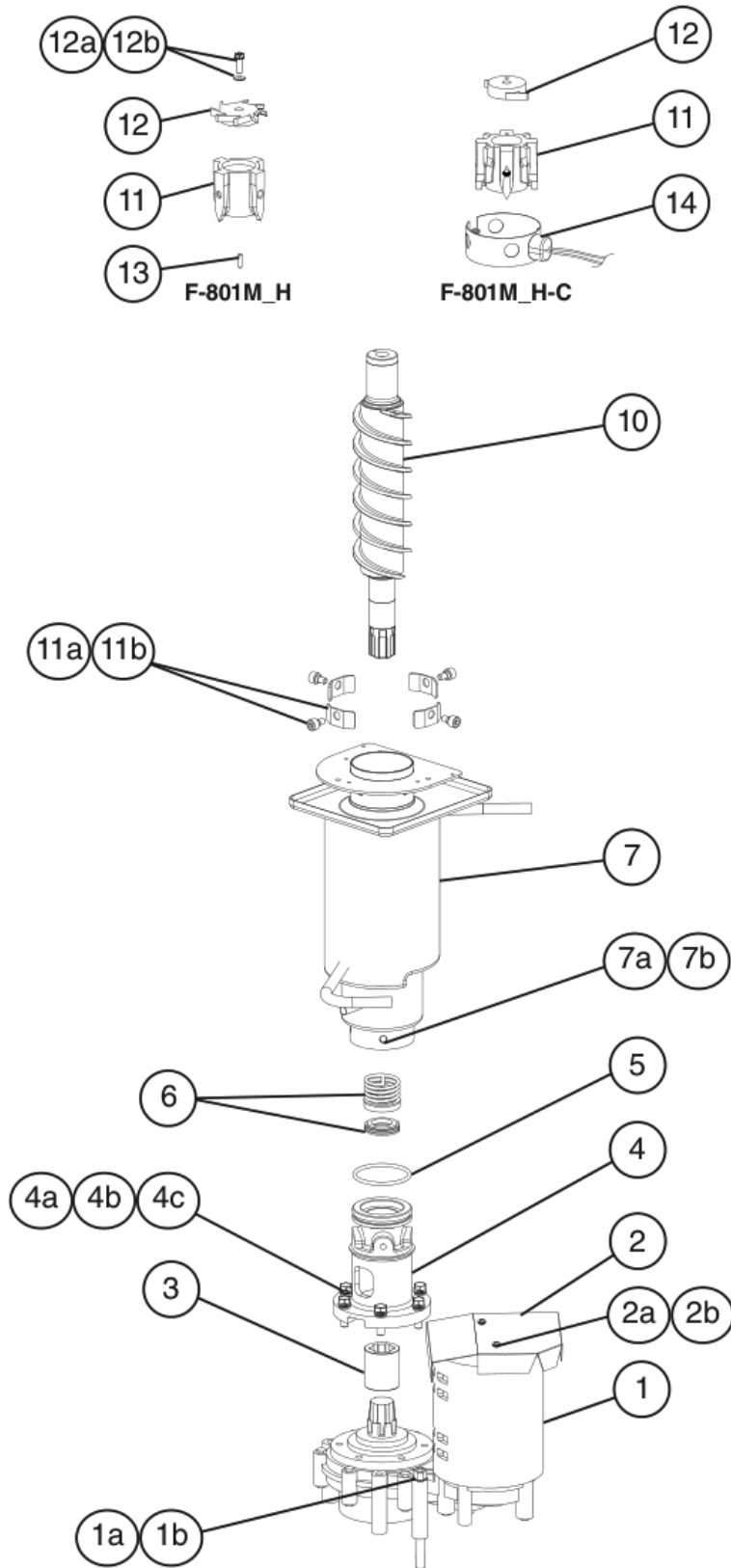

B. Icemaking Unit
F-801M_H(-C)
2/2
 D-2 to F-0

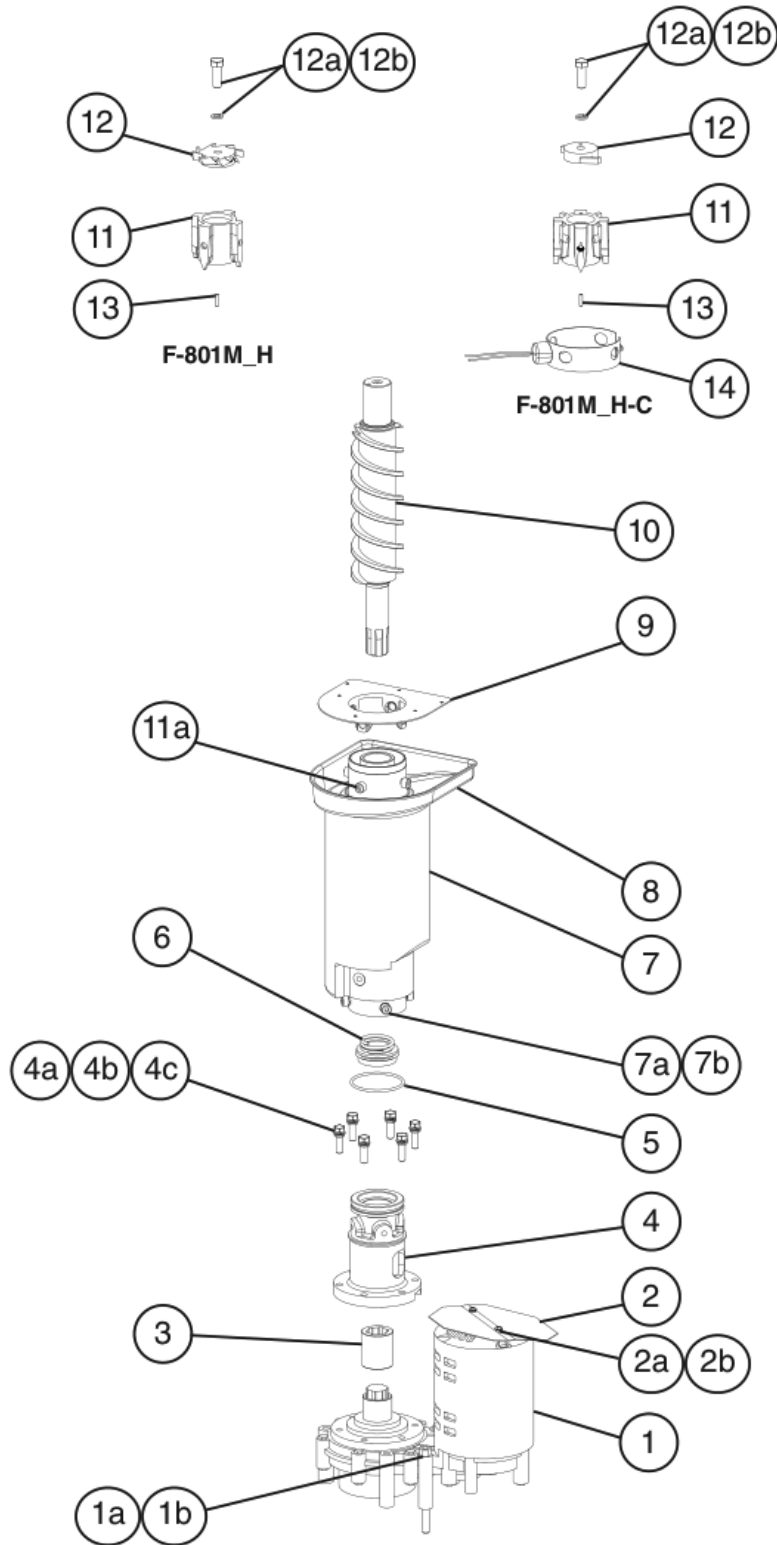

Title: B. Icemaking Unit Model: F-801M_H(-C)										
Index No.	Description	Material or Model Number	Part Number	Required Number						
				N-0 to D-1	D-2 to F-0					
1	Gear Motor		4A2007-01	1	1					
1a	Socket Head Cap Screw	8x110, SS	7S12-0811	3	3					
1b	Split Lock Washer		7L22-0800	3	3					
2	Gear Motor Barrier		3A1732-01	1	-					
			4A4029-01		1					
2a	Truss Head Screw	4x8, SS	7C32-0408	2	2					
2b	Rubber Washer		4A5268-01	2	2					
3	Spline Coupling		414137-01	1	1					
4	Housing		2A1977G01	1	1					
4a	Hex Head Bolt	8x30, SS	7B02-0830	6	6					
4b	Plain Washer		7W22-0800	6	6					
4c	Split Lock Washer		7L22-0800	6	6					
5	O-Ring		4A4755-02	1	1					
6	Mechanical Seal		432492-01	1	1					
7	Evaporator (D-2 and later utilize separate drip pan and flange - items 8 and 9)		2A3312G01	1	-					
			2A7209G01		1					
7a	Socket Head Cap Screw	8x12, SS	7S12-0812	4	4					
7b	Split Lock Washer		7L22-0800	4	4					
8	Drip Pan		2A7187-01		1					
9	Flange		352713-01		1					
10	Auger		120863G02	1	1					
11	Extruding Head	F-801M_H	3A2175G01	1	1					
		F-801M_H-C	3A2176G01	1	1					
11a	Seal Bolt		P01768-02	4	4					
11b	Washer		427184-01	4	-					
12	Cutter	F-801M_H	3A1395-02	1	1					
		F-801M_H-C	327145-01	1	1					
12a	Hex Head Bolt		7B02-1030	1	1					
12b	Split Lock Washer		7L22-1000	1	1					
13	Dowel Pin		713S-0416	1	1					
14	Evaporator Heater	F-801M_H-C	4A2292-01	1	1					

C. Water Circuit
F-801M_H(-C)
1/2
N-0 to D-1

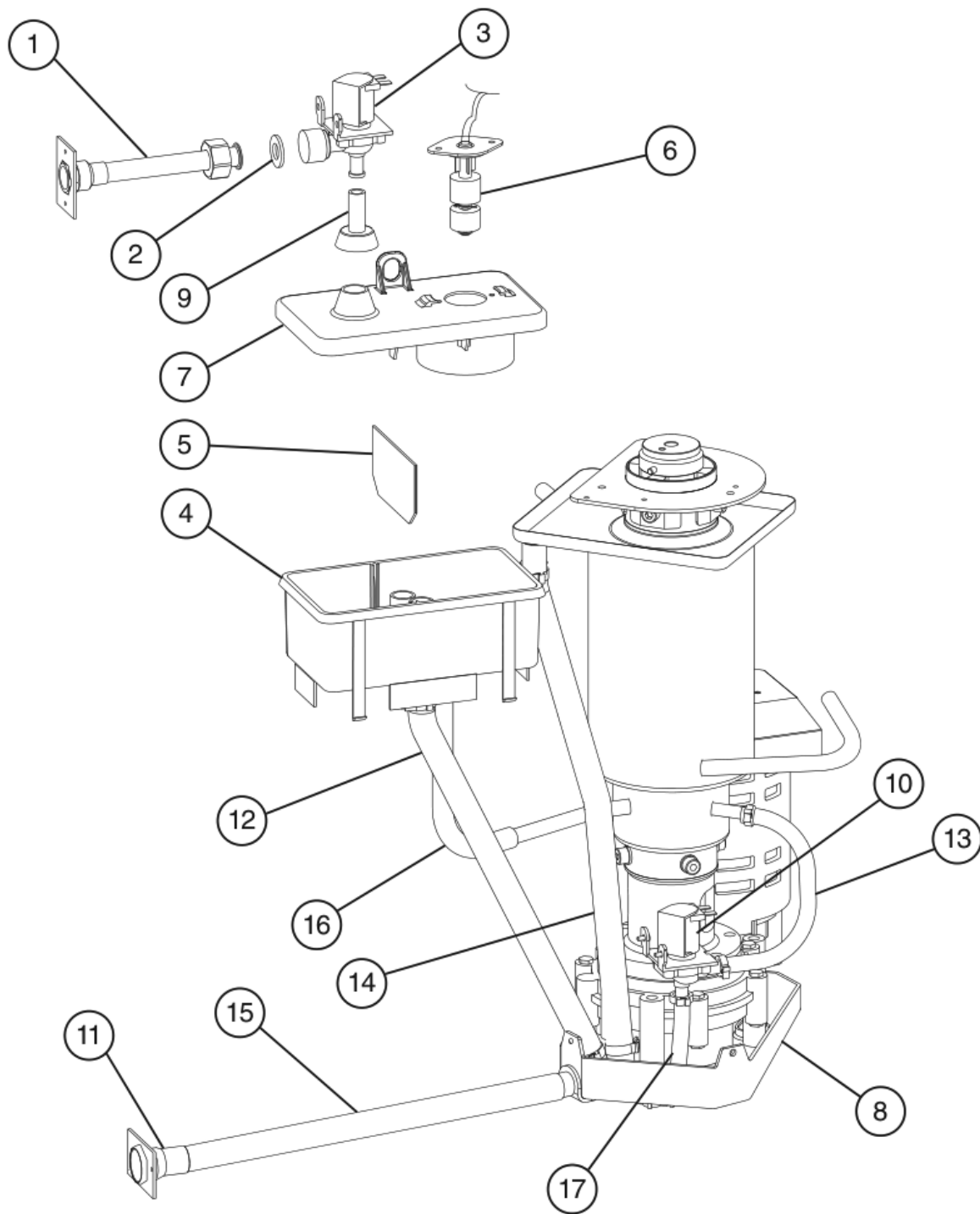

C. Water Circuit
F-801M_H(-C)
2/2
D-2 to F-0

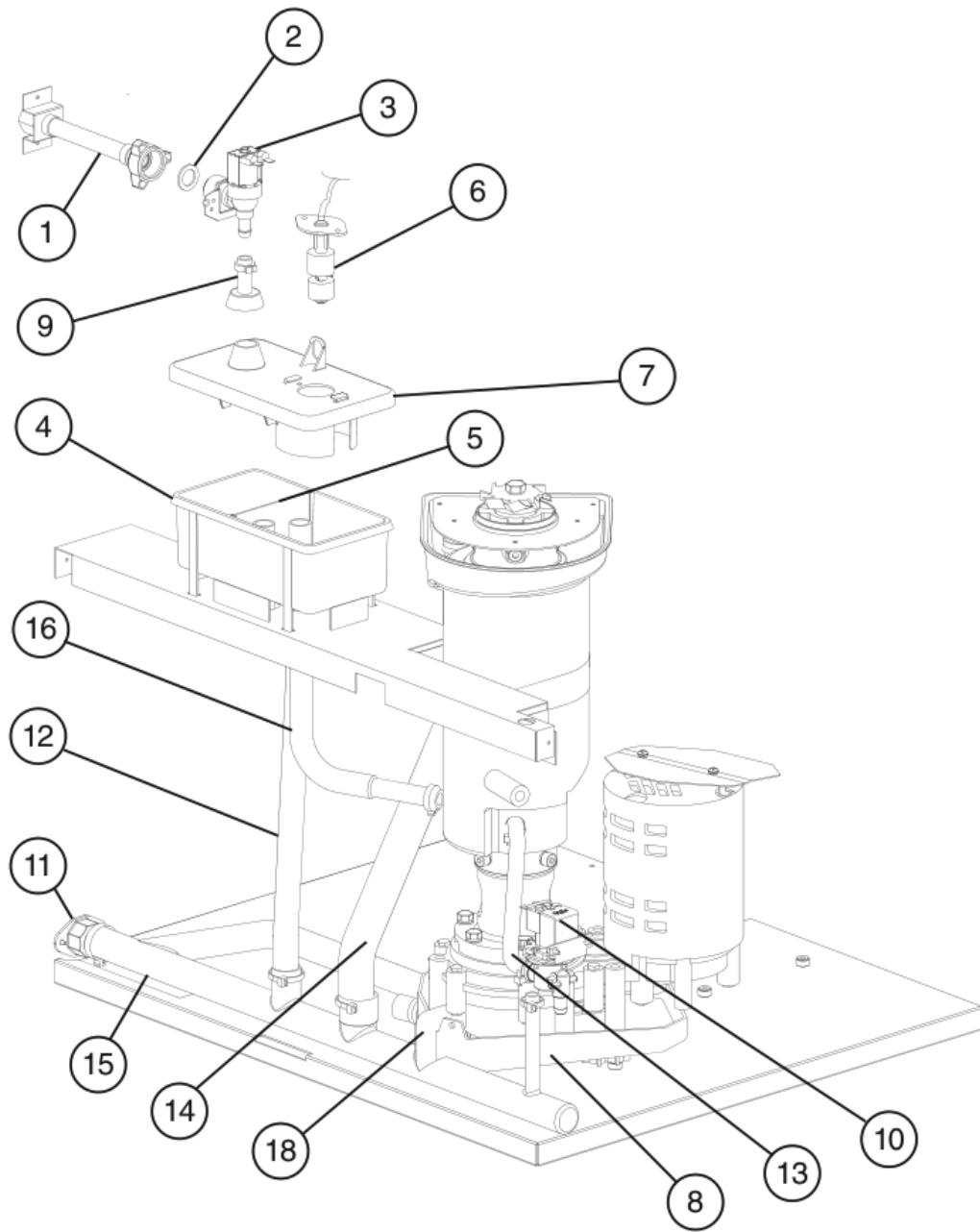

Title: C. Water Circuit Model: F-801M_H(-C)

Index No.	Description	Material or Model Number	Part Number	Required Number									
				N-0 to B-0	B-1 to C-0 (A)	C-0 (B) to D-0	D-1 to F-0						
1	Water Supply Pipe		4A0891G01	1	-								
			4A0891G02		1	1	1						
2	Washer		4A0867-01	1	1	-							
			413854-03			1	1						
3	Inlet Water Valve		4A0865-01	1	-								
			4A5309-01		1	1	1						
4	Reservoir		2A0753-01	1	1	1	1						
5	Reservoir Separator		4A1255-01	1	1	1	1						
6	Float Switch		435490-01	1	1	1	1						
7	Reservoir Cover		214810-01	1	1	1	1						
8	Drain Pan		323765G02	1	1	1	1						
9	Reservoir Inlet		4A0869-01	1	1	1	1						
10	Drain Valve		4A2772-02	1	1	1	1						
11	Drain Fitting		4A0776G01	1	1	1	-						
			4A5528-01				1						
12	Vinyl Hose	L=440 mm	7730-1822	1	-								
			7725-1923		1	1	1						
13	Silicone Hose	L=225 mm	773013896	1	1	1	1						
14	Vinyl Hose	L=460 mm	7725-1923	1	-								
			4A0658L01		1	1	1						
15	Drain Hose	L=400 mm	7716-2025	1	1	1	-						
			3A8170-01				1						
16	Reservoir Hose		4A1165-06	1	1	1	1						
17	Vinyl Hose	L=69 mm	7716-0913	1	-								
18	Elbow		4A5624-01		1	1	1						
Clamps													
	Hose Clamp	26-30 mm	4A2017-02	1	1	1	1						
	Hose Clamp	17-20 mm	4A2017-05	1	1	1	1						
	Hose Clamp	19-22 mm	4A2017-06	1	1	1	1						
	Hose Clamp	14-15 mm	4A2017-08	1	1	1	1						

D. Control Box Assembly
F-801M_H(-C)
N-0 to F-0

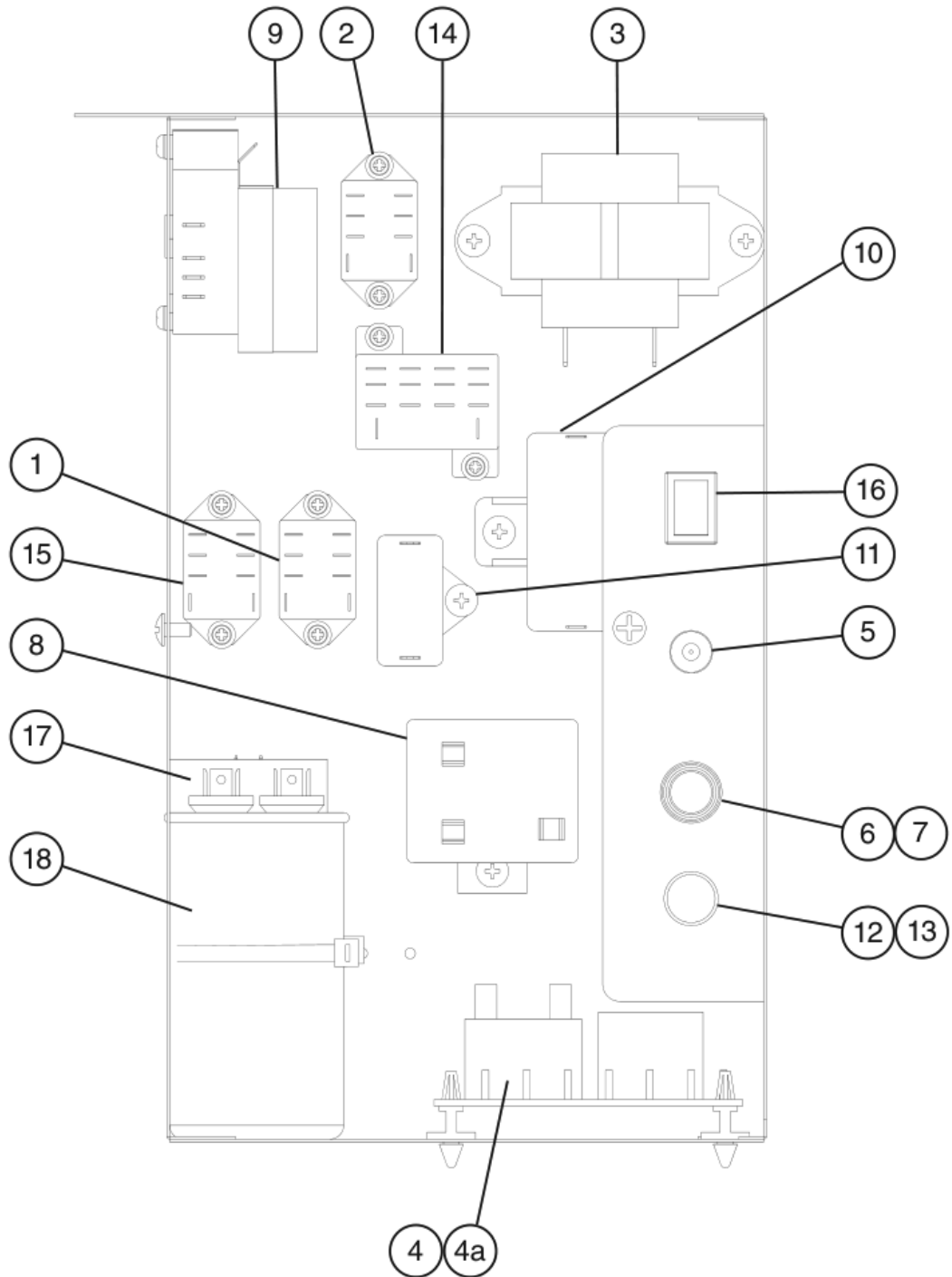

Title: D. Control Box Assembly Model: F-801M_H(-C)												
Index No.	Description	Material or Model Number	Part Number	Required Number								
				N-0 to V-1	V-2 to V-1	B-0 to C-0	C-1 to F-0					
1	Gear Motor Protect Relay (compressor control relay)	120VAC	418271-03	1	1	1	1					
2	Water Control Relay	24VAC	406132-03	1	1	1	1					
3	Control Transformer		4A0557-01	1	1	1	1					
4	Control Board		437305-01	1	1	1	-					
			4A5591-01				1					
4a	Control Board Support		4A0336-03	4	4	4	4					
5	Power Switch		4A2332-01	1	1	1	1					
6	Fuse Holder (control)		4A0892-01	1	-							
			4A5443-01		1	1	1					
7	Fuse (control)	AGC-1A, 250VAC	4A0893-01	1	1	1	1					
8	Start Relay		4A1107-11	1	1	1	1					
9	Drain Timer		4A2157-01	1	1	1	1					
10	Gear Motor Capacitor	24MFD, 250VAC	4A2273-01	1	1	1	1					
11	Fan Motor Capacitor	F-801MAH(-C) 5MFD, 250VAC	443192-02	1	1	1	1					
12	Fuse (gear motor)	GMD-3A, 250VAC Slow Blow	4A0893-06	1	1	1	1					
13	Fuse Holder (gear motor)		4A3449-02	1	1	1	1					
14	Gear Motor Relay	24VAC	406133-04	1	1	1	1					
15	Circuit Protect Relay	220/240VAC	418271-05	1	1	1	1					
16	Control Switch		4A0558-01	1	1	1	1					
17	Start Capacitor	145-174MFD, 220VAC Refer to SB12-0004R1	3A0076-10	1	-							
		243-292MFD, 165VAC	3A0076-20		1	1	1					
18	Run Capacitor	15MFD, 370VAC Refer to SB12-0004R1	3A2005-08	1	-							
		35MFD, 440VAC	3A2005-12		1	1	1					

E. Accessories & Labels

F-801M_H(-C)

N-0 to F-0

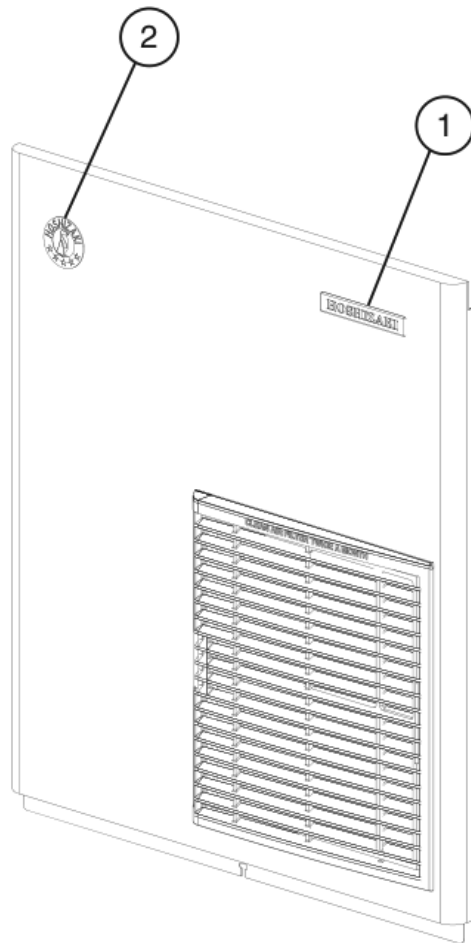

Title: E. Accessories & Labels Model: F-801M_H(-C)										
Index No.	Description	Material or Model Number	Part Number	Required Number						
				N-0 to F-0						
1	Hoshizaki Emblem Label		4A0560-01	1						
2	Penguin Label		475552L02	1						
3	Universal Brace		4A0363-01	2						
3a	Hex Bolt		7B02-0512	2						