



HOSHIZAKI

Parts List

Modular Flaker
Serenity Series

Models
FS-1500MLJ-C



hoshizakiamerica.com

Number: 73234
Issued: 3-12-2019
Revised: 12-2-2019

CONTENTS

Auxiliary Codes.....	3
Note About Ordering Parts	3
A. Main Assembly & Refrigeration Circuit	4
B. Icemaking Unit	6
C. Water Circuit	8
D. Control Box Assembly.....	10
E. Accessories & Labels	11

Auxiliary Codes

FS-1500MLJ-C

H-0 July 2018

J-0 January 2019

Auxiliary Code Breakdown

The auxiliary code is the first two characters in the serial number. The first character indicates the year. Years progress or regress in alphabetical order. The series runs from "A" through "V" and the letters "I" and "O" are skipped. The second character indicates significant part changes within a year. Base is "0" and this number advances for each change. In cases where there is a letter in parentheses, this designates the month. This is the last character in the serial number. The series runs from "(A)" through "(M)" and the letter "(I)" is skipped. This designation is only included when identifying a parts change within an auxiliary code.

Note About Ordering Parts

Most assemblies cannot be ordered as complete units; parts in the assemblies generally must be ordered separately.

A. Main Assembly & Refrigeration Circuit
FS-1500MLJ-C
 H-0, J-0

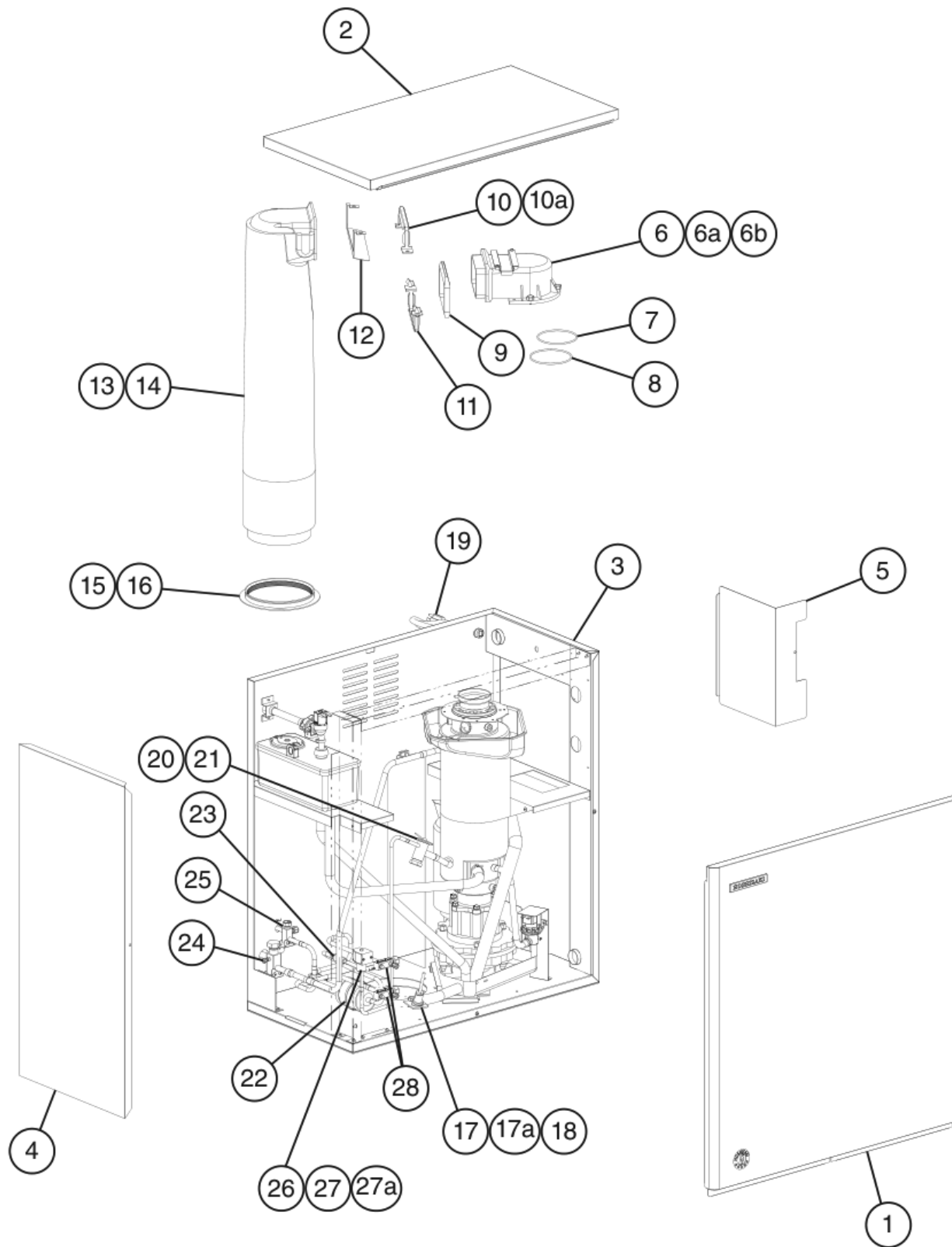

Title: A. Main Assembly & Refrigeration Circuit Model: FS-1500MLJ-C												
Index No.	Description	Material or Model Number	Part Number	Required Number								
				H-0								
Main Assembly												
1	Front Panel		2A6492-01	1								
2	Top Panel		2A6491-01	1								
3	Right Side Panel		2A6489G01	1								
4	Left Side Panel		2A6490G01	1								
5	Control Box Cover		3A6671-01	1								
6	Spout		105378G01	1								
6a	Thumbscrew		415949G10	4								
6b	Spout Cover		4A5174-01	1								
7	O-Ring		4A4755-05	1								
8	Nylon Ring		431736-01	1								
9	Spout-to-Chute Packing		327040-01	1								
10	Upper Spout-to-Chute Strap		3A6912-02	1								
10a	Wing Nut		7E12-0600	2								
11	Lower Spout-to-Chute Strap		3A6913G01	1								
12	Drip Guide		3A1628-01	1								
13	Chute		216219-04	1								
14	Chute Insulation		216220-01	1								
15	Chute Packing		432877-02	1								
16	Ring		327427-01	1								
17	Bin Control Housing (infrared sensor)		3A3478-01	1								
17a	Thumbscrew		415949G10	1								
18	Bin Control (infrared sensor)		4A4469-01	1								
19	Power Cord		4A1773-01	1								
Refrigeration Circuit												
20	Thermostatic Expansion Valve		4A3493-01	1								
21	Thermostatic Expansion Valve Cover		4A1168-01	1								
22	Drier		4A1338-01	1								
23	Strainer		4A1385-01	1								
24	Suction Shut Off Valve		4A3490-01	1								
25	Liquid Shut Off Valve		4A3491-01	1								
26	Liquid Line Valve Body		4A3276-01	1								
27	Valve Coil		4A3277-01	1								
27a	Bolt		4A3277F01	1								
28	Service Valve		4A3420-01	2								

B. Icemaking Unit
FS-1500MLJ-C
H-0, J-0

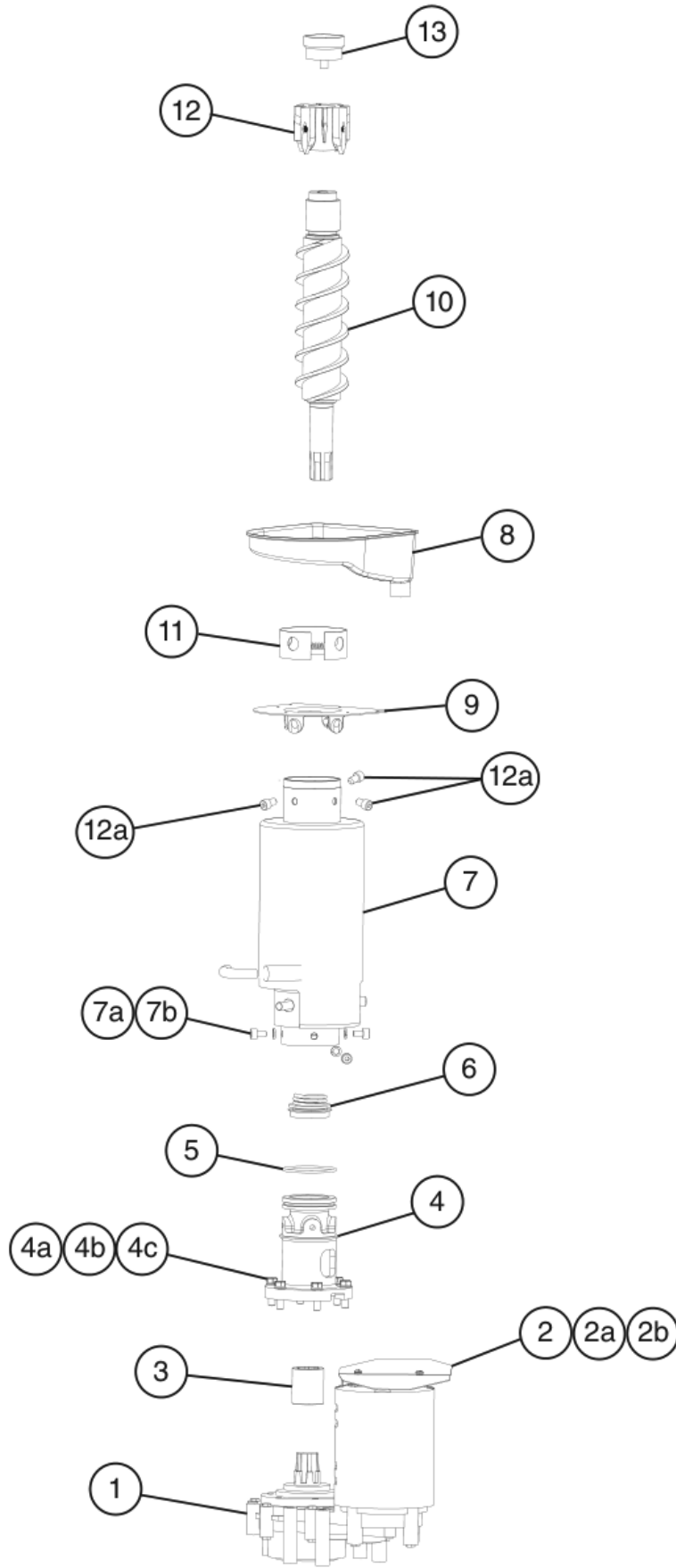

Title: B. Icemaking Unit Model: FS-1500MLJ-C												
Index No.	Description	Material or Model Number	Part Number	Required Number								
				H-0	J-0							
1	Gear Motor		2U0129-01	1								
2	Gear Motor Barrier		3A1639-01	1								
2a	Rubber Washer		4A5268-01	2								
2b	Truss Head Screw	4x8	7C32-0408	2								
3	Spline Coupling		420372-01	1								
4	Housing		206509G02	1								
4a	Hex Head Bolt	8x30	4A5640-01	6								
4b	Flat Washer		7W22-0800	6								
4c	Split Lock Washer		7L22-0800	6								
5	O-Ring		4A4755-04	1								
6	Mechanical Seal		432493-01	1								
7	Evaporator		2A7005G01	1								
7a	Split Lock Washer		7L22-1000	4								
7b	Socket Head Cap Screw	10x20	7S12-1020	4								
8	Drip Pan		2A6885-01	1								
9	Flange		352714-01	1								
10	Auger		120864G02	1								
11	Evaporator Heater		4A4335-01	1								
12	Extruding Head		264203G02	1								
12a	Seal Bolt		474757G02	3								
13	Cutter		315736G01	1								

Title: C. Water Circuit Model: FS-1500MLJ-C												
Index No.	Description	Material or Model Number	Part Number	H-0 J-0	Required Number							
Main Assembly												
1	Water Supply Pipe		4A0891G02	1								
2	Rubber Gasket		413854-03	1								
3	Inlet Water Valve		4A5309-01	1								
4	Reservoir		208125-01	1								
5	Reservoir Separator		423538-02	1								
6	Reservoir Cover		208126-01	1								
7	Float Switch		435490-01	1								
8	Reservoir Inlet		4A0869-01	1								
9	Reservoir Hose		4A1551-01	1								
10	Drain Valve		4A2772-02	1								
11	Drain Fitting		4A5527-01	1								
12	Vinyl Hose	L=400 mm	7716-2025	1								
13	Vinyl Hose	L=630 mm	4A0658L01	1								
14	Vinyl Hose	L=680 mm	7725-1923	1								
15	Silicone Hose	L=60 mm	7730I3896	1								
16	Silicone Hose	L=280 mm	7730I3896	1								
Hose Clamps												
	Hose Clamp	21-26 mm	4A2017-01	1								
	Hose Clamp	14-15 mm	4A2017-08	1								

D. Control Box Assembly
FS-1500MLJ-C
H-0, J-0

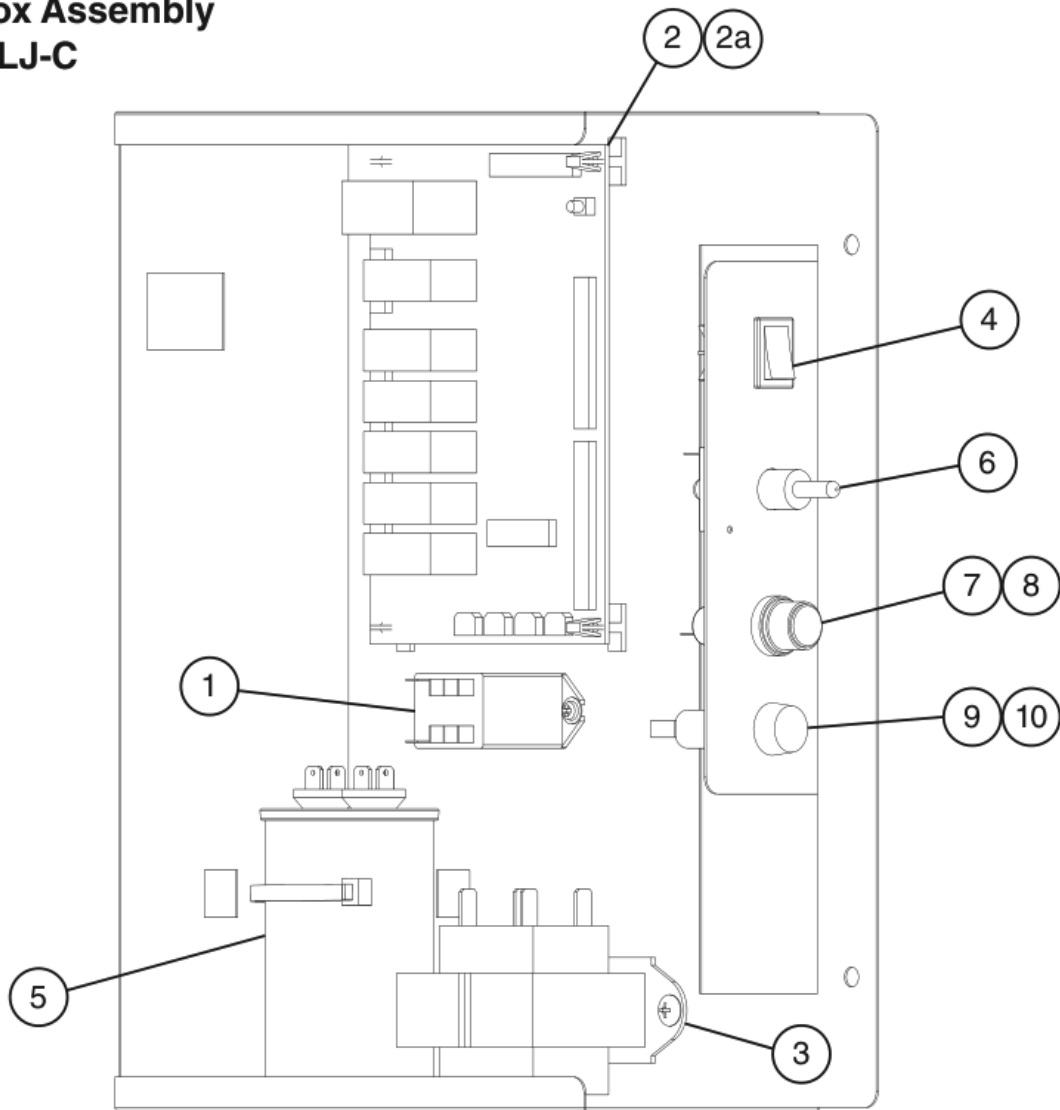

Title: D. Control Box Assembly Model: FS-1500MLJ-C																		
Index No.	Description	Material or Model Number	Part Number	Required Number														
				H-0	J-0													
1	Compressor Control Relay		418271-03	1														
2	Control Board		2A8054-01	1														
2a	Control Board Support		4A0336-03	4														
3	Control Transformer		4A0557-01	1														
4	Control Switch		4A0558-01	1														
5	Run Capacitor		4A5450-01	1														
6	Power Switch		4A2332-01	1														
7	Fuse Holder		4A5443-01	1														
8	Control Board Fuse	AGC-1A, 250VAC	4A0893-01	1														
9	Fuse Holder		4A3449-02	1														
10	Gear Motor Fuse	GMD-3A, 250VAC Slow Blow	4A3804-01	1														

E. Accessories & Labels
FS-1500MLJ-C
H-0, J-0

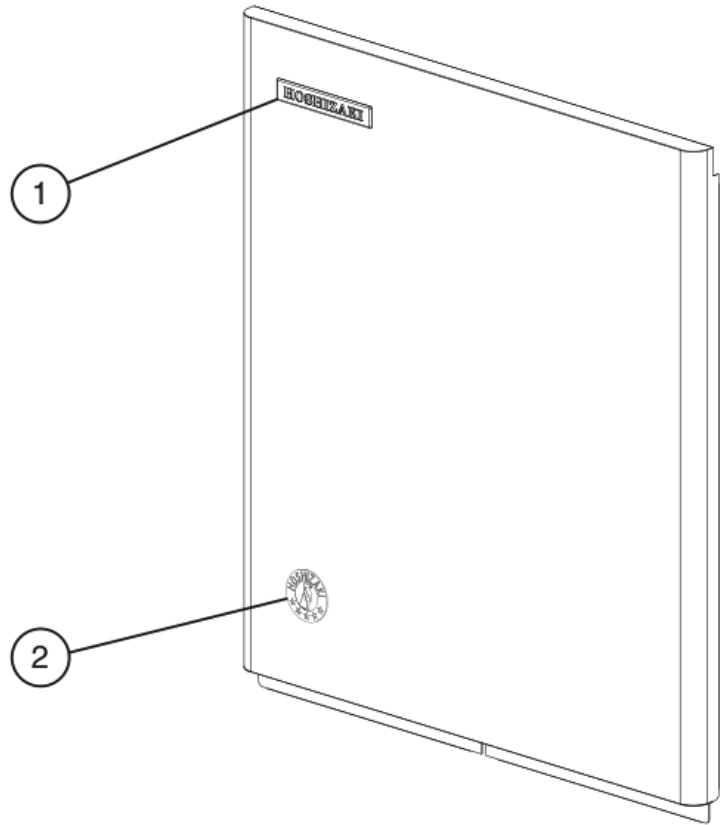

Title: E. Accessories & Labels Model: FS-1500MLJ-C											
Index No.	Description	Material or Model Number	Part Number	Required Number							
				H-0	J-0						
1	Emblem		4A0560-01	1							
2	Penguin Label		475552L02	1							
3	Universal Bracket		4A3668-01	2							
3a	Hex Bolt		7B02-0512	4							
3b	Self-Drilling Bolt		7P1111234	4							