



HOSHIZAKI

Parts List

Water Electrolyzer

Model
ROX-20TB2-U



hoshizakiamerica.com

Number: X002-3586
Issued: 3-2017

ROX-20TB2-U	A-1	September 2011
	B-0	January 2012
	C-0	January 2013
	D-1	January 2014
	E-1	July 2015

Auxiliary Code Breakdown

The auxiliary code is the first two characters in the serial number. The first character indicates the year. Years progress or regress in alphabetical order. The series runs from "A" through "V" and the letters "I" and "O" are skipped. The second character indicates significant part changes within a year. Base is "0" and this number advances for each change. In cases where there is a letter in parentheses, this designates the month. This is the last character in the serial number. The series runs from "(A)" through "(M)" and the letter "(I)" is skipped. This designation is only included when identifying a parts change within an auxiliary code.

Note About Ordering Parts

Most assemblies cannot be ordered as complete units; parts in the assemblies generally must be ordered separately.

MARKS LOCATED UNDER THE AUXILIARY CODE

- = Part deleted.
- x = Part deleted and replaced by "o" part.
- o = New part in place of "x" part.

FASTENER PART NUMBER

SCREWS

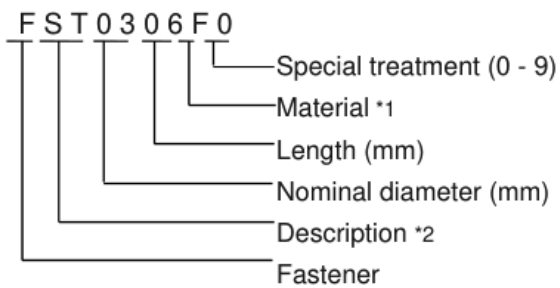

*1

- F: Steel
- S: Austenitic stainless steel
- M: Martensitic stainless steel
- B: Copper alloy
- P: Polycarbonate
- N: Polyamide
- V: PVC
- A: ABS
- X: Polyacetal
- L: Aluminum

NUTS & WASHERS

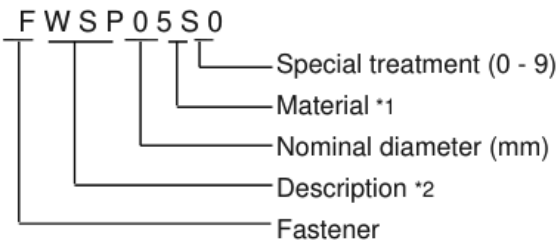

*2

- First letter
- S: Machine screw
- T: Tapping screw
- M: Wood screw
- B: Bolt
- W: Washer
- N: Nut

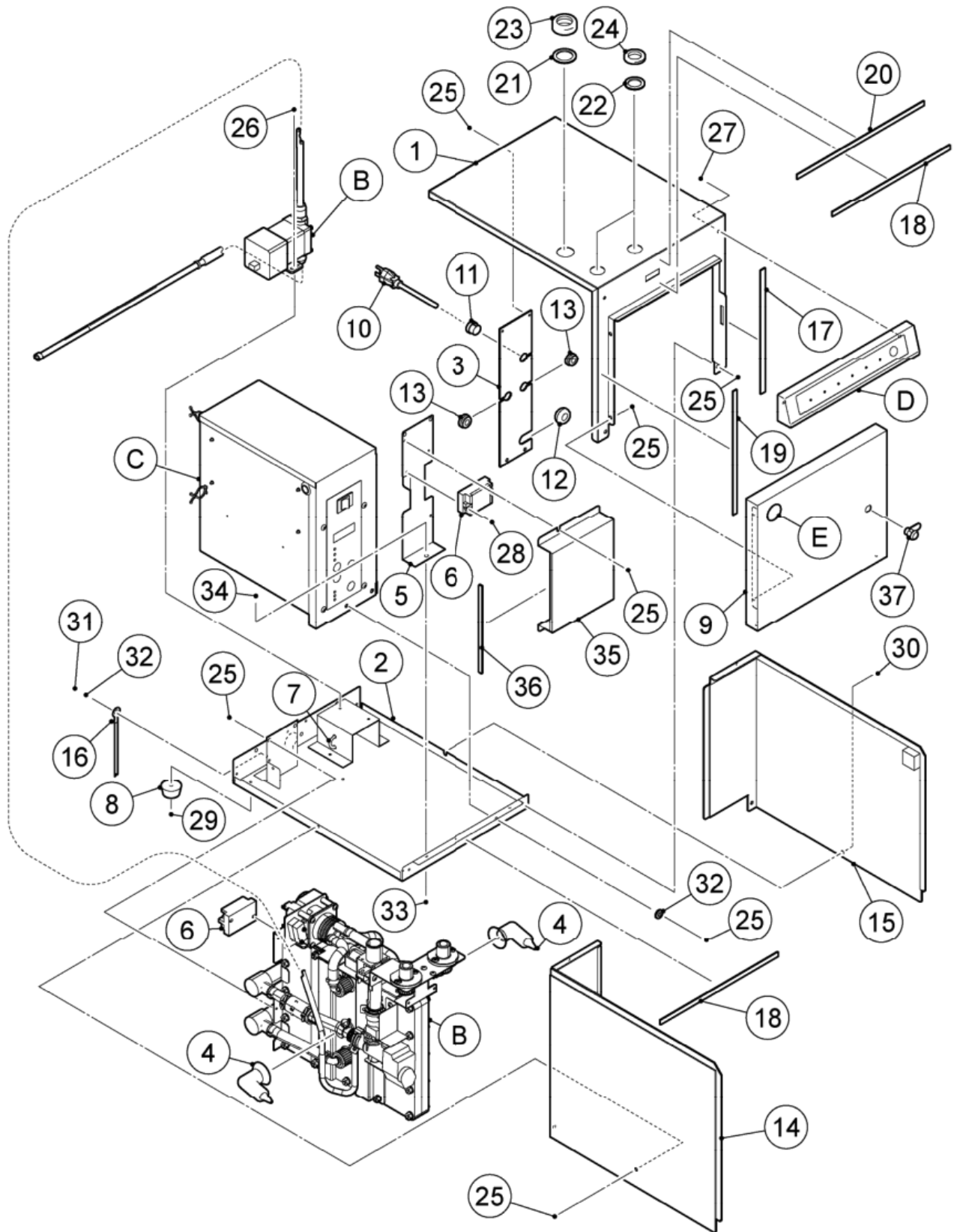

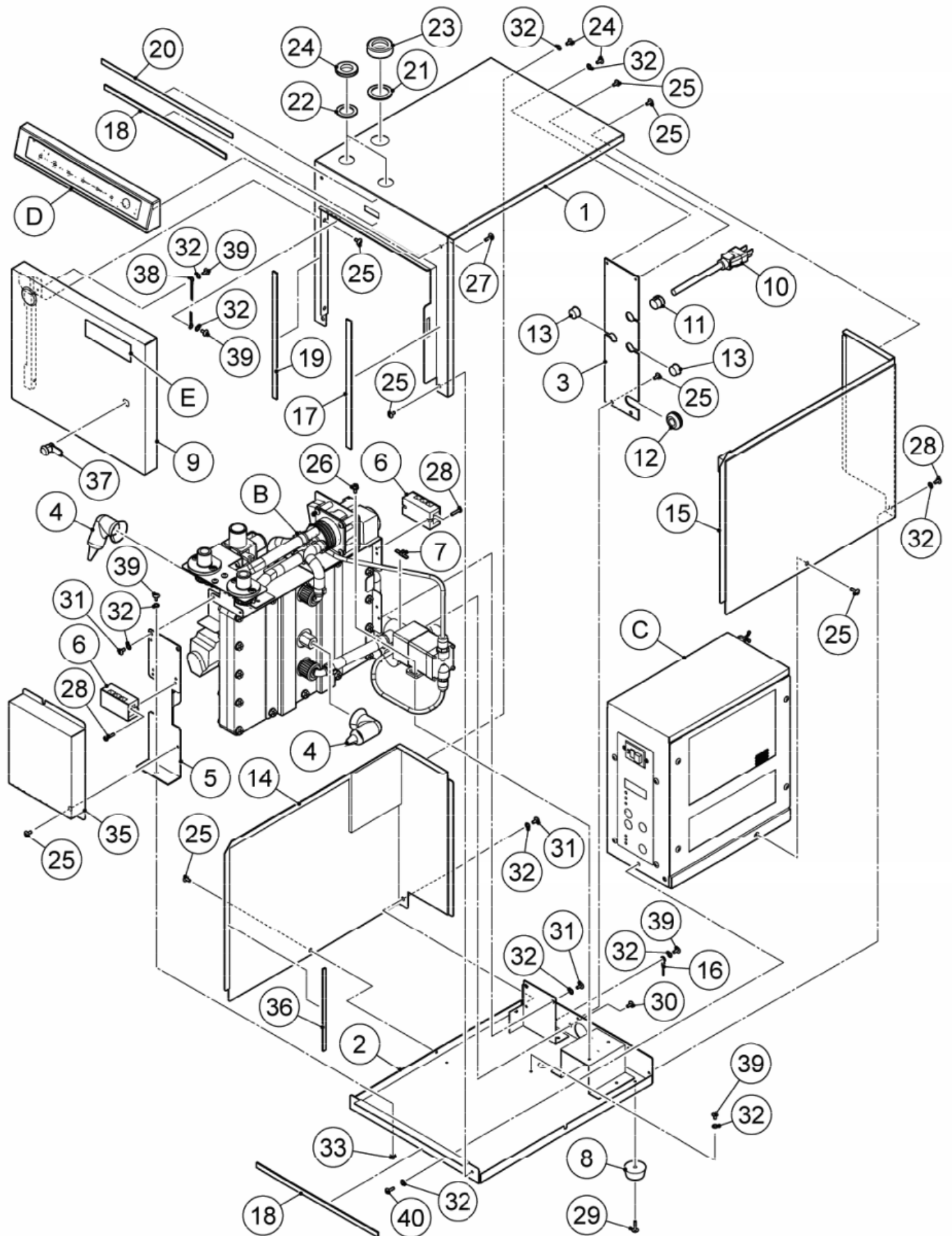

MODEL: **ROX-20TB2-U**TITLE: **A. WATER ELECTROLYZER ASSY**

INDEX NO.	DESCRIPTION	MATERIAL OR MODEL NUMBER	PART NUMBER	REQ'D NUMBER			
				A-1 D-0	D-1 E-0	E-1	
B	WATER CIRCUIT ASSY		121429A01	1	1	1	
C	CONTROL BOX ASSY		121460A01	1	1	1	
D	OPERATION PANEL ASSY		364518A01	1	1	1	
E	LABEL LOCATION		375589A01	1	1	1	
L	ACCESSORIES		A02398-01	1	1	1	
N	ACCESSORIES		A02399-01	1	1	1	
1	COVER ASSY		375484G01	1	1	1	
2	BOTTOM PLATE		370590G01	1	1	1	
3	REAR PANEL		468949-01	1	1	1	
4	CAP - BOLT		449712-01	2	2	2	
5	STOPPER - ELECTROLYTIC CELL		467714G01	1	1	1	
6	TERMINAL BLOCK	Replace No.5 at the same time for "J0" and earlier auxiliary codes.	P01375-01	2	2	2	
7	TIE	CV-150	7920-0003	1	1	1	
8	RUBBER FOOT (W/WASHER)	C-30RK-3215	418767-02	4	4	4	
9	FRONT COVER ASSY		375219G01	1	-	-	
			379759G01	-	1	1	
10	POWER SUPPLY CORD	XR-0099002	P00004-01	1	1	1	
11	BUSHING		420472-04	1	1	1	
12	GROMMET	BW-10-2	409655-08	1	1	1	
13	BLIND BUSH	BB-0562	455601-02	2	2	2	
14	PANEL (L) ASSY		364522G01	1	1	1	
15	PANEL (R) ASSY		361551G01	1	1	1	
16	EARTH WIRE		NO SUPPLY	1	1	1	
17	MAGNET		452228-01	1	1	1	
18	INSULATION (A)		452227-01	2	2	2	
19	INSULATION (B)		452227-02	1	1	1	
20	INSULATION (B) - OPERATION		452230-02	1	1	1	
21	GASKET		467721-02	1	1	1	
22	GASKET		467721-01	2	2	2	
23	SPACER - WATER SUPPLY		467592-01	1	1	1	

MODEL: **ROX-20TB2-U**TITLE: **A. WATER ELECTROLYZER ASSY**

INDEX NO.	DESCRIPTION	MATERIAL OR MODEL NUMBER	PART NUMBER	REQ'D NUMBER			
				A-1 D-0	D-1 E-0	E-1	
24	SPACER - DISCHARGE		467593-01	2	2	2	
25	TRUSS HEAD TAPPING SCREW T2 (PLASTIC WASHER)	MARTENSITIC STAINLESS STEEL(4 X 8)	FT70408M0	22	13	13	
26	HEX HEAD BOLT (SPRING WASHER AND FLAT WASHER)	AUSTENITIC STAINLESS STEEL (4 X 10)	FBK0410S0	2	2	2	
27	TRUSS HEAD MACHINE SCREW (PLASTIC WASHER)	AUSTENITIC STAINLESS STEEL (4 X 16)	FSG0416S0	2	-	-	
	TRUSS HEAD SCREW P		FSG0412S0	-	2	2	
28	PAN HEAD MACHINE SCREW	STTEL (4 X 16) CHROMATE TREATED	FSP0416F0	4	4	4	
29	TRUSS HEAD TAPPING SCREW T2	MARTENSITIC STAINLESS STEEL(4 X 16)	FT20416M0	4	4	4	
30	TRUSS HEAD TAPPING SCREW T2 (PLASTIC WASHER)	MARTENSITIC STAINLESS STEEL(4 X 12)	FT70412M0	1	1	1	
31	TRUSS HEAD TAPPING SCREW (S-TITE)	STTEL (4 X 8) CHROMATE TREATED	FTS0408F0	2	2	2	
	T2 TRUSS HEAD SCREW		FT20408M0	-	8	8	
32	TOOTH WASHER	AUSTENITIC STAINLESS STEEL (4)	FWTB04S0	3	3	3	
	CONICAL TOOTHED LOCK WASHER M4		P03266-01	-	14	14	
33	CAP NUT	AUSTENITIC STAINLESS STEEL (4)	FNDC04S0	1	1	1	
34	TRUSS HEAD MACHINE SCREW (PLASTIC WASHER)	AUSTENITIC STAINLESS STEEL (4 X 8)	FSG0408S0	1	-	-	
35	BOARD GUARD		361552-01	1	1	1	
36	INSULATION - PANEL (L)		467823-01	1	1	1	
37	COIN LOCK	C-88-8A	458003-01	1	1	1	
38	HARNESS/DOOR EARTH		379761Z01	-	1	1	
39	S-TITE TRUSS HEAD SCREW		FTS0408M0	-	5	5	
40	TRUSS HEAD SCREW		FST0412S0	-	1	1	

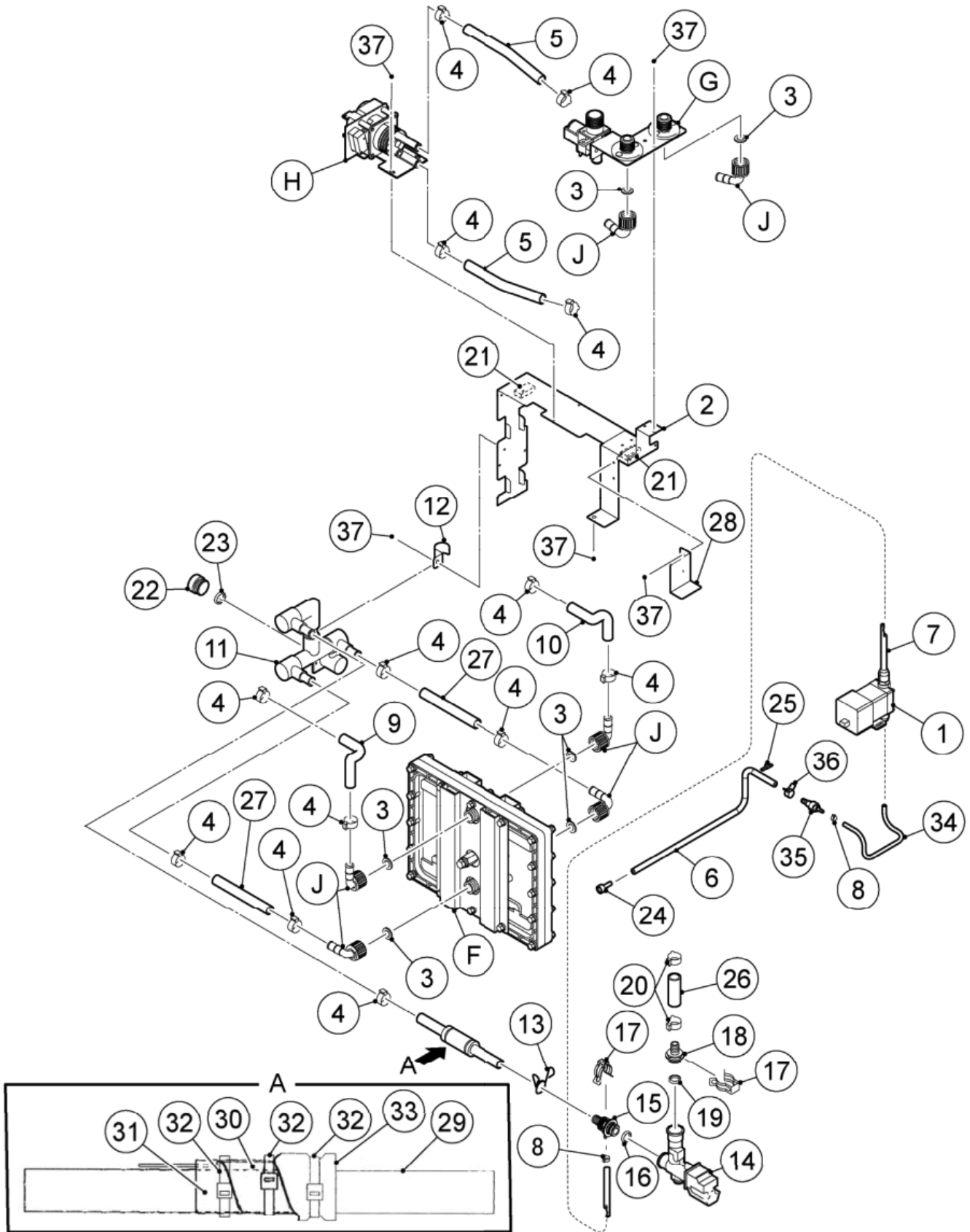

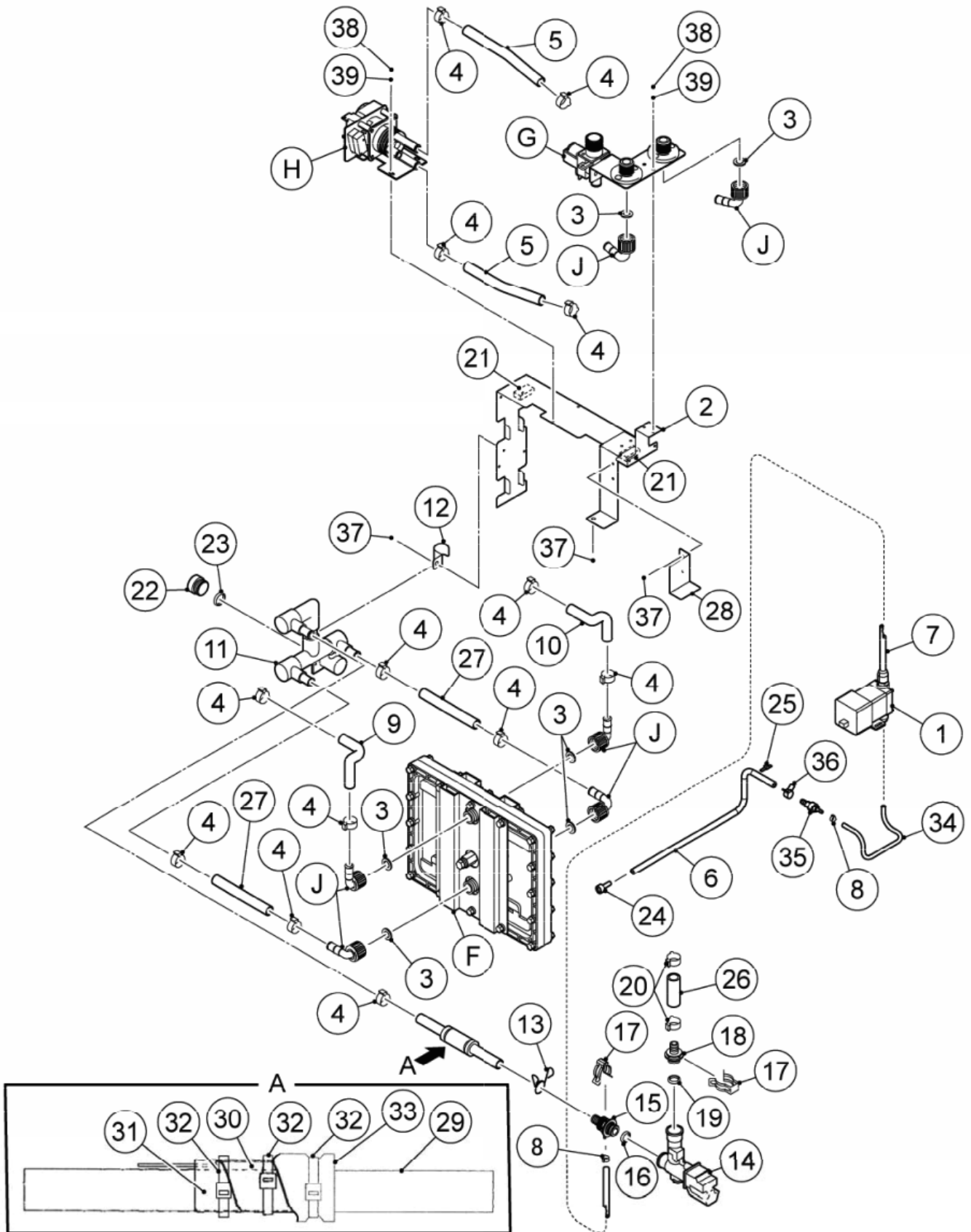

MODEL: **ROX-20TB2-U**TITLE: **B. WATER CIRCUIT ASSY**

INDEX NO.	DESCRIPTION	MATERIAL OR MODEL NUMBER	PART NUMBER	REQ'D NUMBER			
				A-1 D-0	D-1 E-0	E-1	
F	ELECTROLYSIS BOX ASSY		108397A06	1	1	1	
G	JOINT ASSY		370591001	1	1	1	
H	CHANGE VALVE ASSY		260609A01	1	1	1	
J	UNION - ELBOW		452176A02	6	6	6	
1	HRP PUMP		P00372-01	1	1	1	
2	FRAME ASSY		361554G01	1	1	1	
3	GASKET - UNION	11DIA x 18.5DIA	475911R01	6	6	6	
4	HOSE CLAMP	CLIC R86-160	460248-01	13	13	13	
5	VINYL HOSE	12DIA x 16DIA L=168±2	HA1216170	2	2	2	
6	BRAIDED HOSE		HB0409H18	1	1	1	
7	VINYL HOSE		HA0306720	1	1	1	
8	HOSE CLAMP		435947-17	2	2	2	
9	HOSE (L) - IN		463331-01	1	1	1	
10	HOSE (R) - IN		463331-02	1	1	1	
11	TEE - WATER SUPPLY DR		364526G01	1	1	1	
12	JOINT - SADDLE		468952-01	1	1	1	
13	HOSE CLAMP	SK-16	435934-04	1	1	1	
14	VALVE - FLOW CONTROL		P00560-01	1	1	1	
15	JOINT (B) - CONTROL VALVE		253488P02	1	1	1	
16	"O"RING		7618-P015	1	1	1	
17	QUICK FASTENER	QUICK-16A-R3	456912-04	2	2	2	
18	JOINT (A) - CONTROL VALVE		361561-02	1	1	1	
19	"O"RING		7618-P016	1	1	1	
20	HOSE CLAMP	CLIC R86-185	460248-07	2	2	2	
21	CUSHION		452229-01	2	2	2	
22	CAP - DRAIN	PVC	458375-01	1	1	1	
23	"O"RING		7618-P020	1	1	1	
24	FILTER		458374G01	1	1	1	
25	TIE	CV-150	7920-0003	1	1	1	
26	HOSE - VALVE		475947P01	1	1	1	

MODEL: **ROX-20TB2-U**TITLE: **B. WATER CIRCUIT ASSY**

INDEX NO.	DESCRIPTION	MATERIAL OR MODEL NUMBER	PART NUMBER	REQ'D NUMBER			
				A-1 D-0	D-1 E-0	E-1	
27	VINYL HOSE	12DIA x 16DIA L=180	HA1216120	2	2	2	
28	VALVE COVER		467850-01	1	1	1	
29	VINYL HOSE	THERMISTOR ASSY (467737G01) 12DIA x 16DIA L=180	467737-01	1	1	1	
30	THERMISTOR	THERMISTOR ASSY (467737G01)	463938-02	1	1	1	
31	VINYL TAPE	THERMISTOR ASSY 15 mm DEEP (467737G01)		1	1	1	
32	TIE	THERMISTOR ASSY (467737G01) CV-150	7920-0003	3	3	3	
33	INSULATION TUBE	THERMISTOR ASSY (467737G01) L=60	467737-04	1	1	1	
34	VINYL HOSE	GI-55	HA0306260	1	1	1	
35	JOINT (B) - CONTROL VALVE		472148P02	1	1	1	
36	CLIP BAND		423866-07	1	1	1	
37	TRUSS HEAD TAPPING SCREW T2 (PLASTIC WASHER)	MARTENSITIC STAINLESS STEEL(4 X 8)	FT70408M0	9	5	5	
38	T2 TRUSS HEAD SCREW		FT20408M0	-	4	4	
39	CONICAL TOOTHED LOCK WASHER M4		P03266-01	-	4	4	

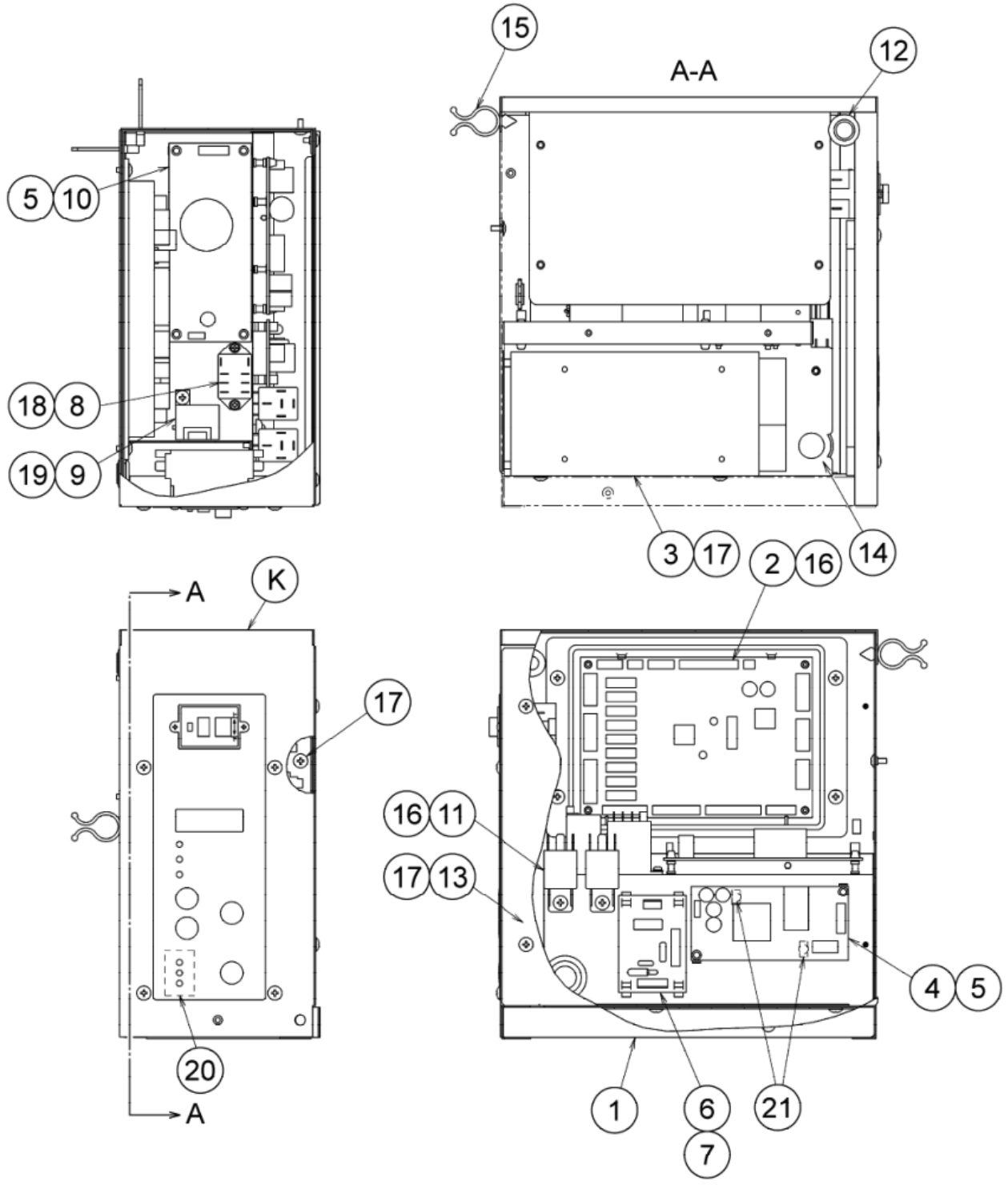

MODEL: **ROX-20TB2-U**TITLE: **C. CONTROL BOX ASSY**

INDEX NO.	DESCRIPTION	MATERIAL OR MODEL NUMBER	PART NUMBER	REQ'D NUMBER			
				A-1 D-0	D-1 E-0	E-1	
K	FRONT PANEL - CONTROLLER		375581A01	1	1	1	
1	BASE - CONTROLLER		370593G01	1	1	1	
2	MAIN BOARD		P03366-06	1	1	1	
3	SWITCHING REGULATOR	HWS300-15	P00558-01	1	1	1	
4	SWITCHING REGULATOR	LDA10F-5-M-MR	461871-02	1	1	1	
5	BOARD SUPPORT	2451	449969-01	6	6	6	
6	NOISE ABSORBER	PC05911-3	P00545-02	1	1	1	
7	BOARD SUPPORT	KGLS-4S	414929-02	4	4	4	
8	RELAY	LY2F DC12V	406132-09	1	1	1	
9	CURRENT SENSOR	HC-TN020V2PP12	452215-01	1	1	1	
10	SWITCHING REGULATOR	LDA30F-12V	P00036-01	1	1	1	
11	RELAY - CB	ACB13401 P02	467409-01	2	2	2	
12	MEMBRANE GROMMET	C-30-SG-14A	410666-19	1	1	1	
13	COVER - CONTROLLER		370595G01	1	1	1	
14	MEMBRANE GROMMET	C-30-SG-22A	410666-05	1	1	1	
15	WIRE RETAINER	No.4253	427902-05	1	1	1	
16	TRUSS HEAD MACHINE SCREW (PLASTIC WASHER)	AUSTENITIC STAINLESS STEEL (4 X 8)	FSG0408S0	6	6	6	
17	TRUSS HEAD MACHINE SCREW	AUSTENITIC STAINLESS STEEL (4 X 8)	FST0408S0	9	9	9	
18	PAN HEAD MACHINE SCREW (SPRING WASHER & FLAT WASHER)	AUSTENITIC STAINLESS STEEL (3 X 8)	FSK0308S0	2	2	2	
19	TRUSS HEAD MACHINE SCREW	AUSTENITIC STAINLESS STEEL (4 X 30)	FST0430S0	1	1	1	
20	CUSHION - LAMPGUIDE		472614Z01	1	1	1	
21	CARD SPACER	PA66	455115-01	2	2	2	

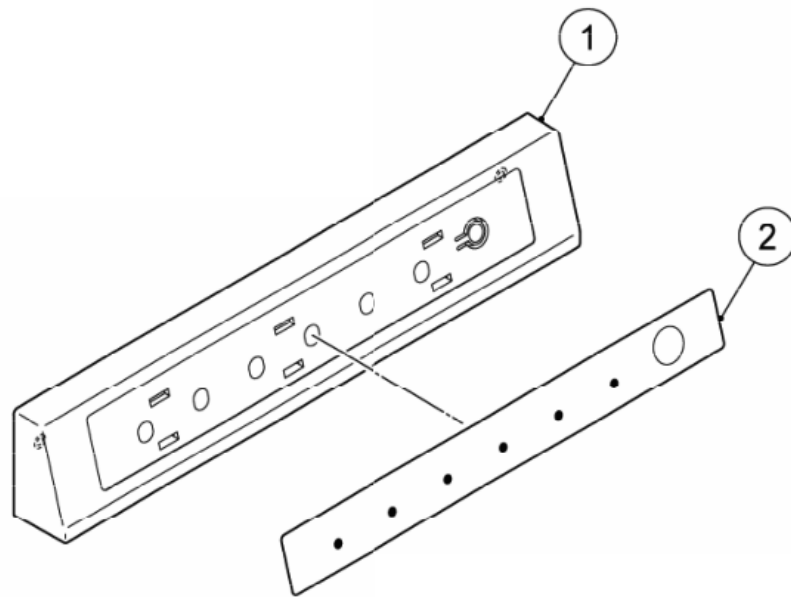

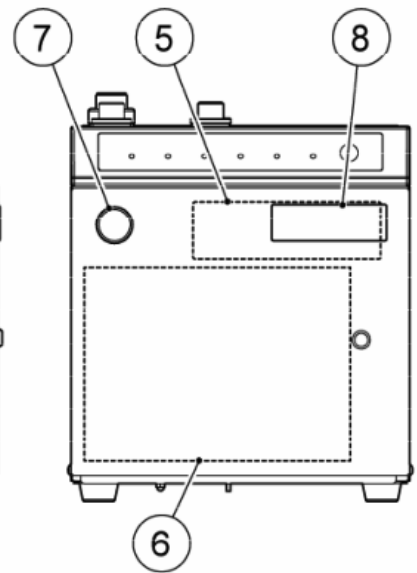
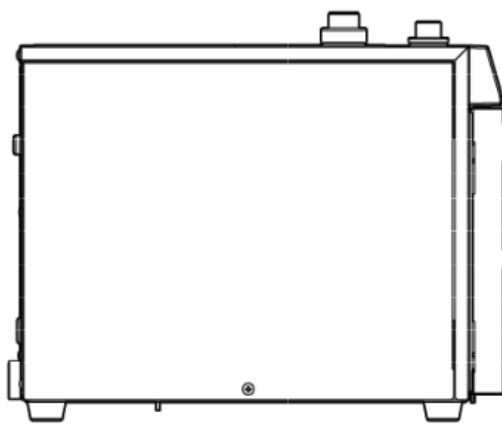
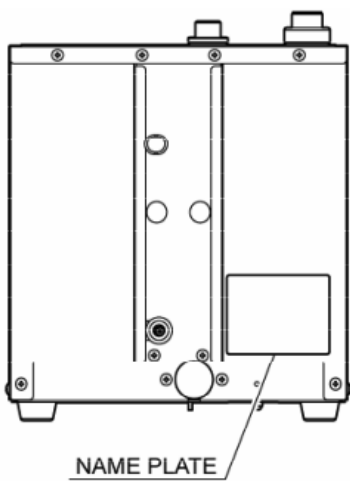
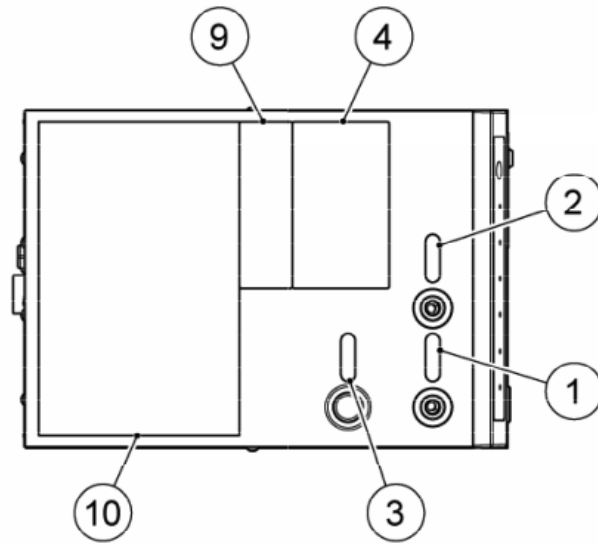

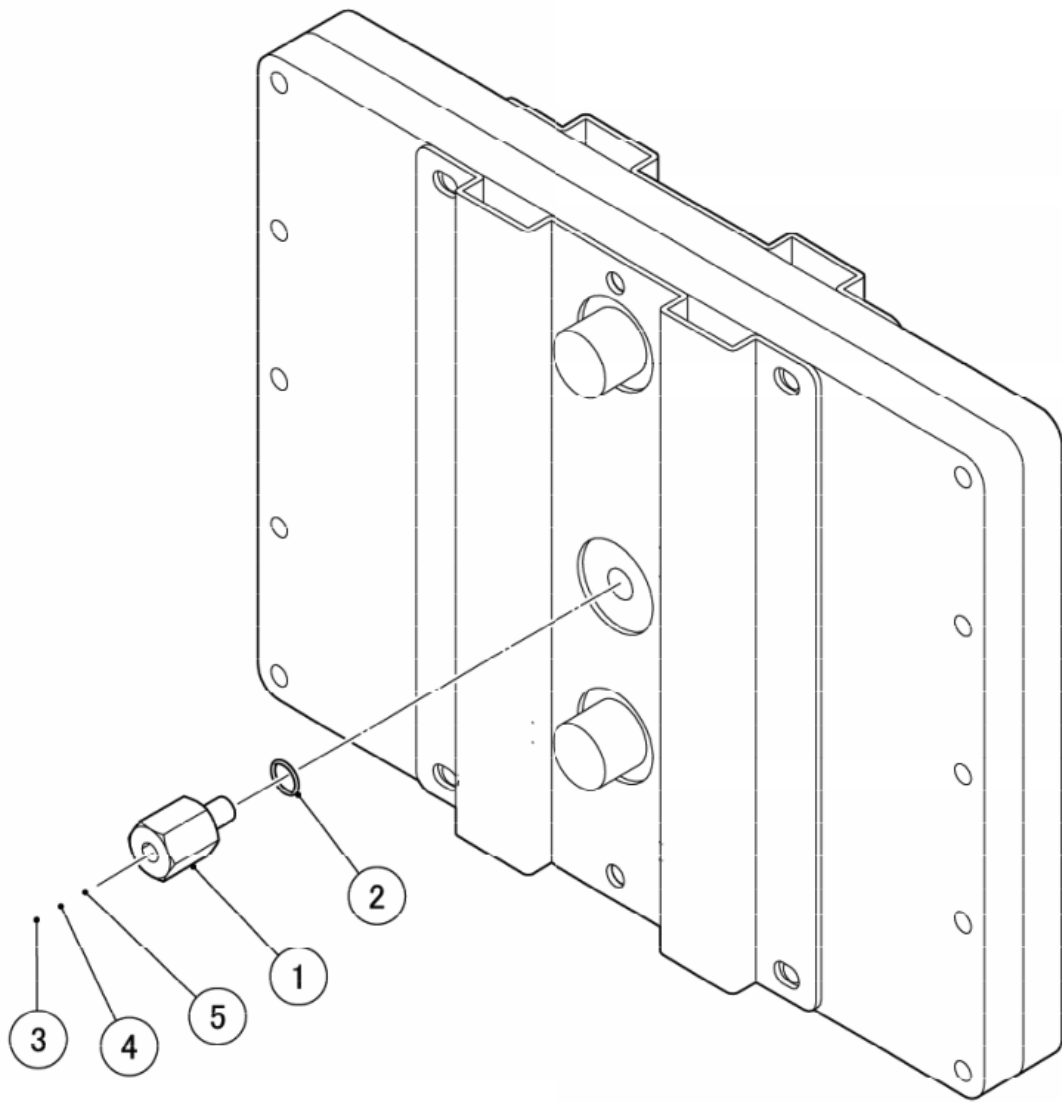

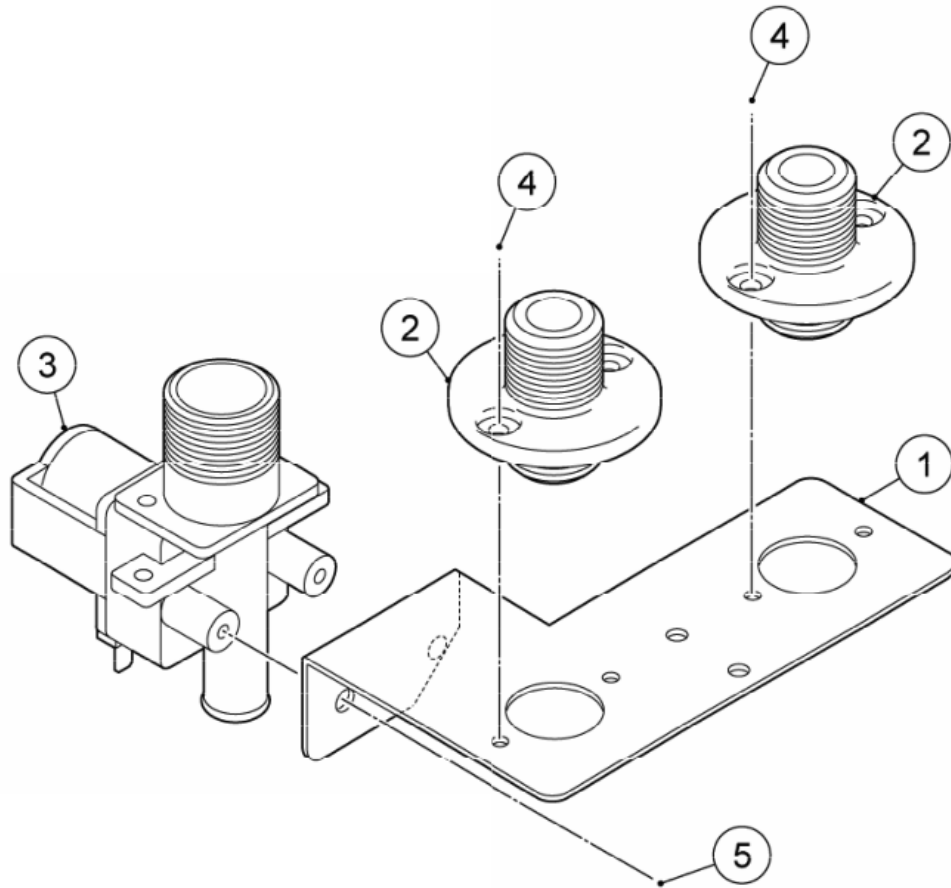

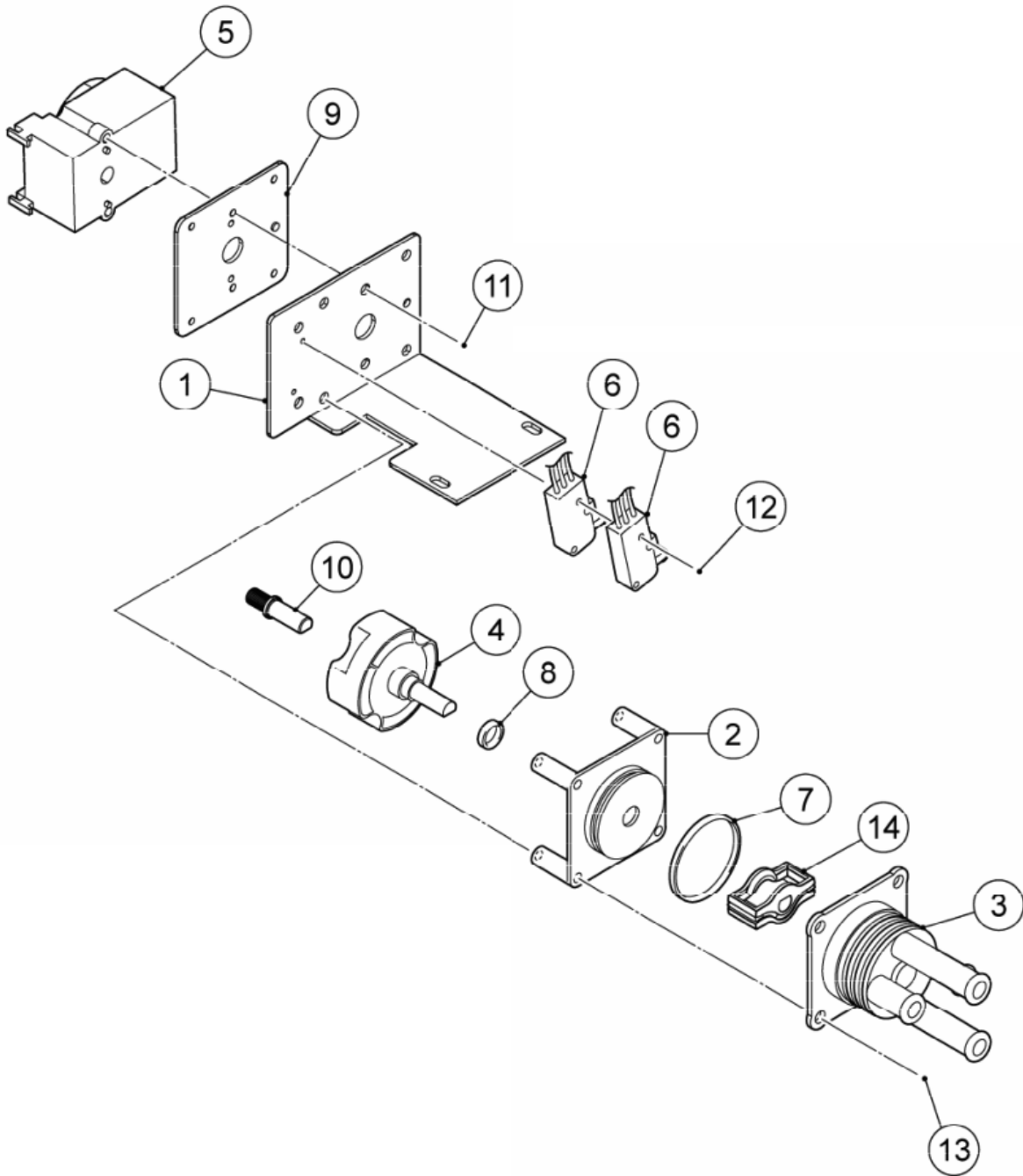

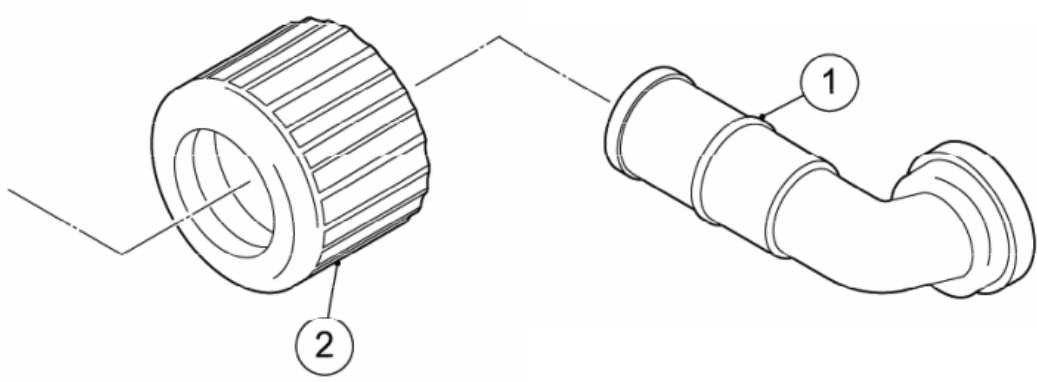

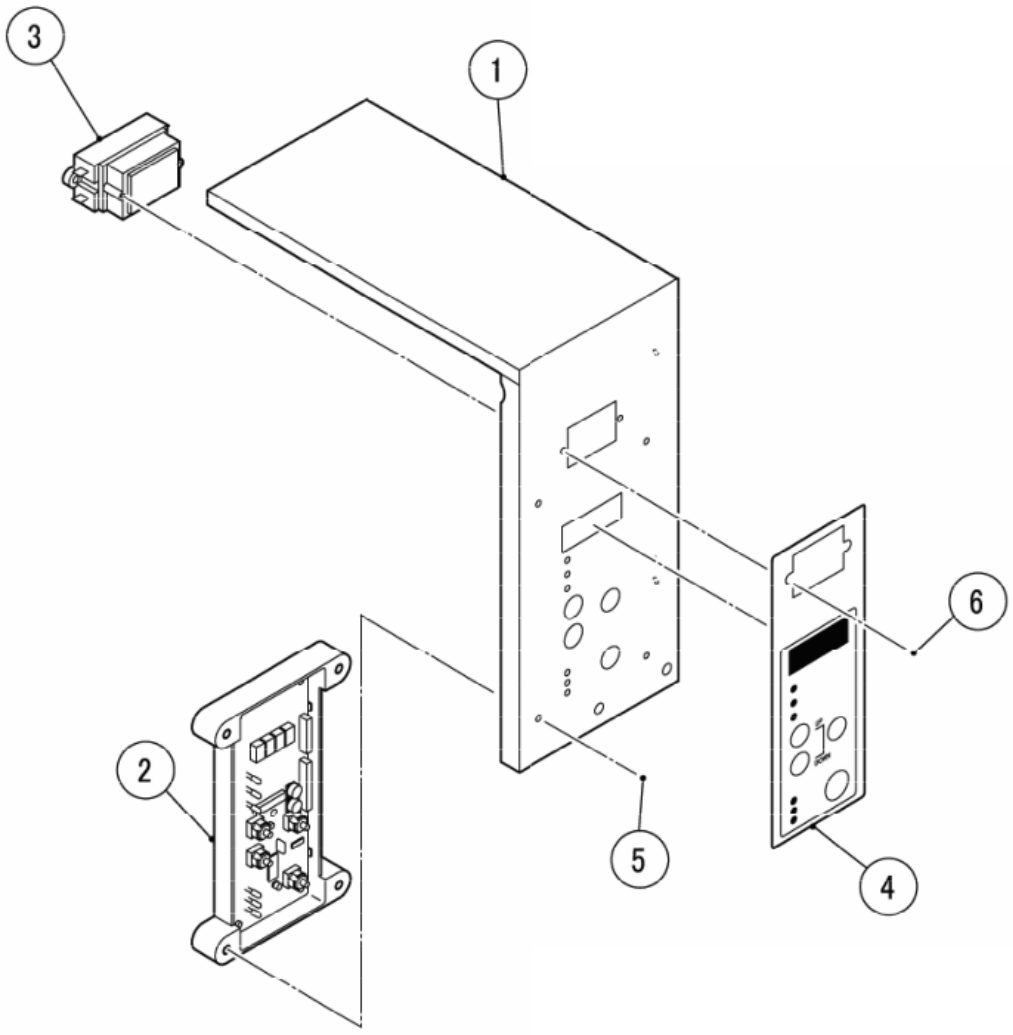

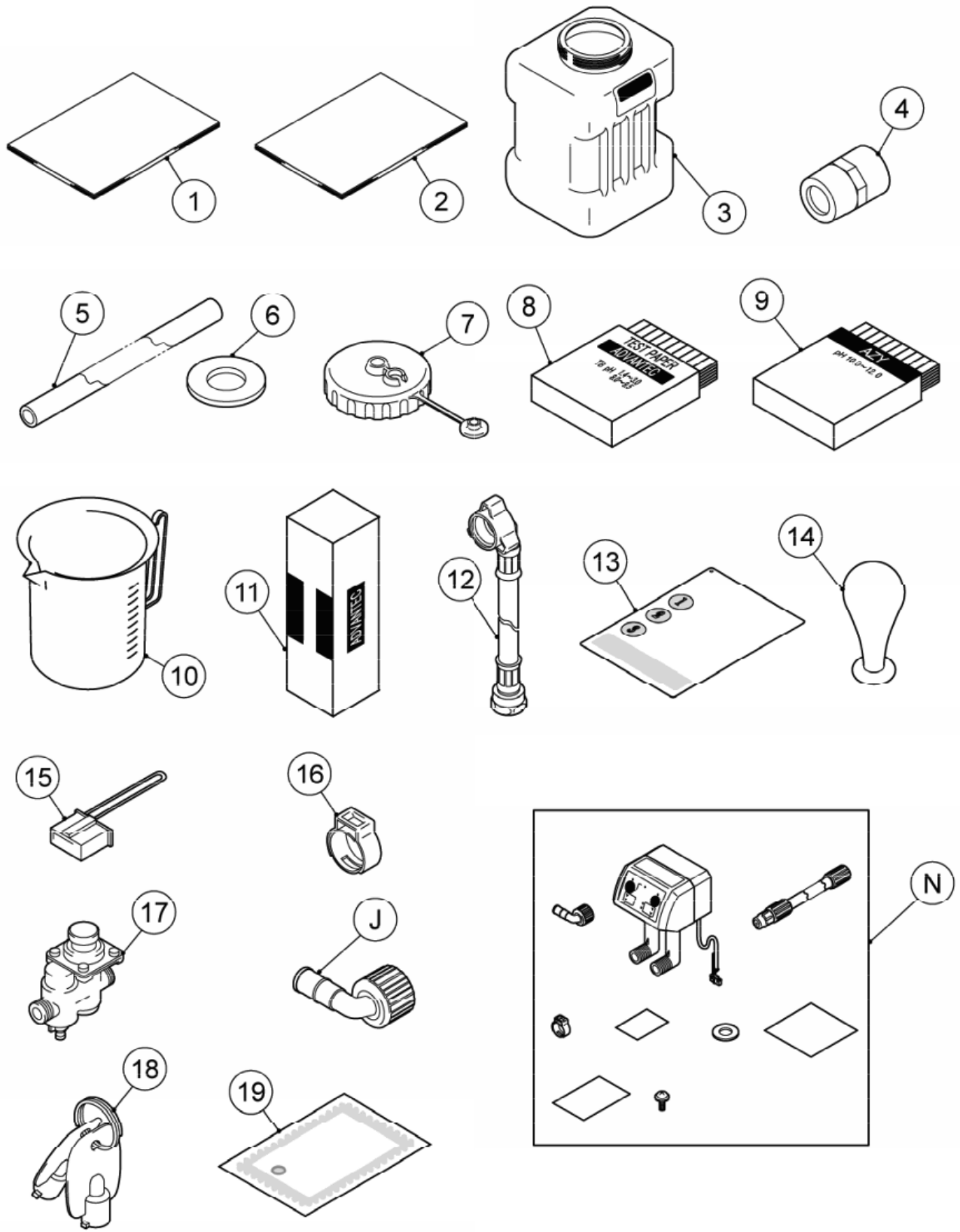

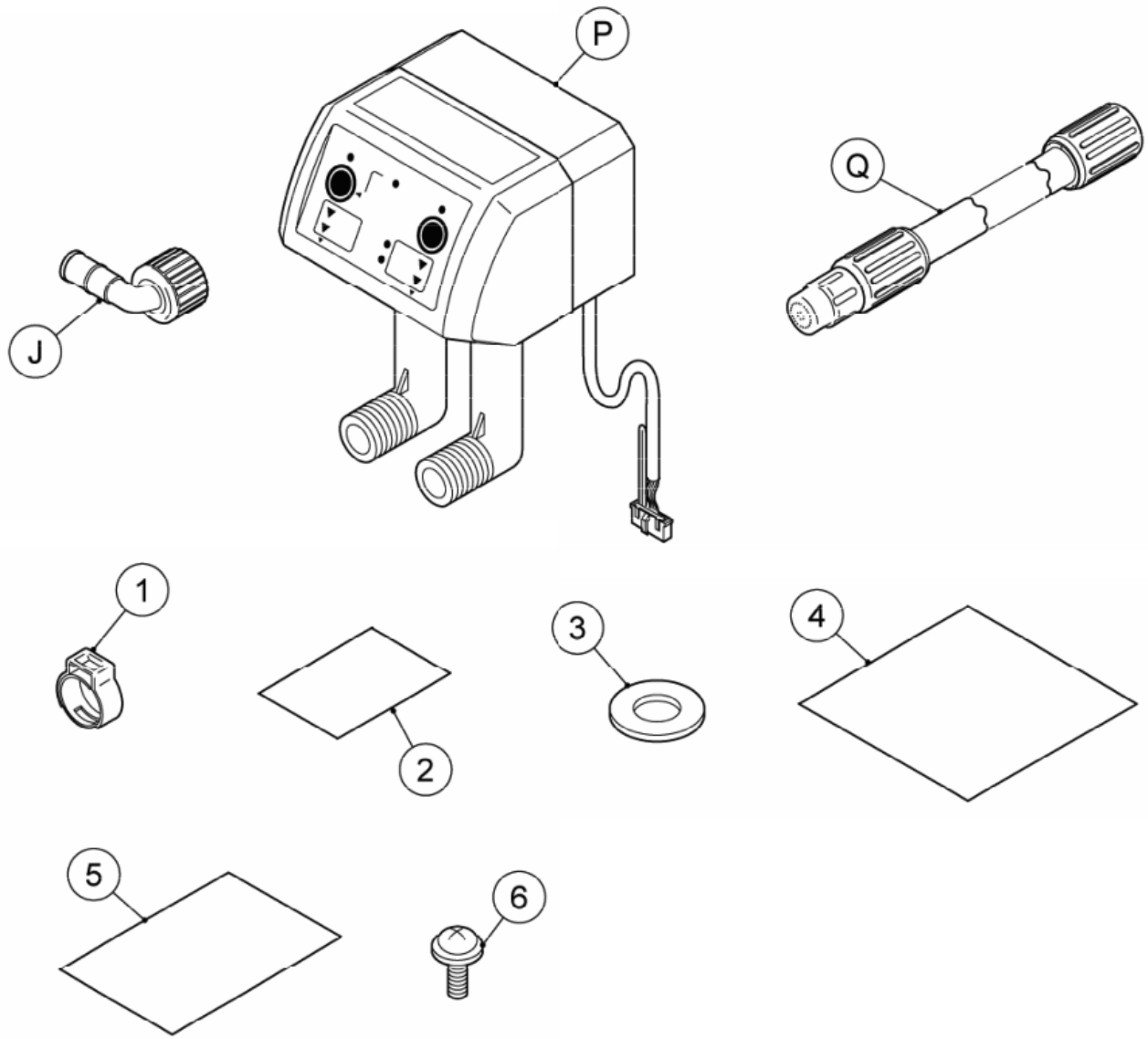

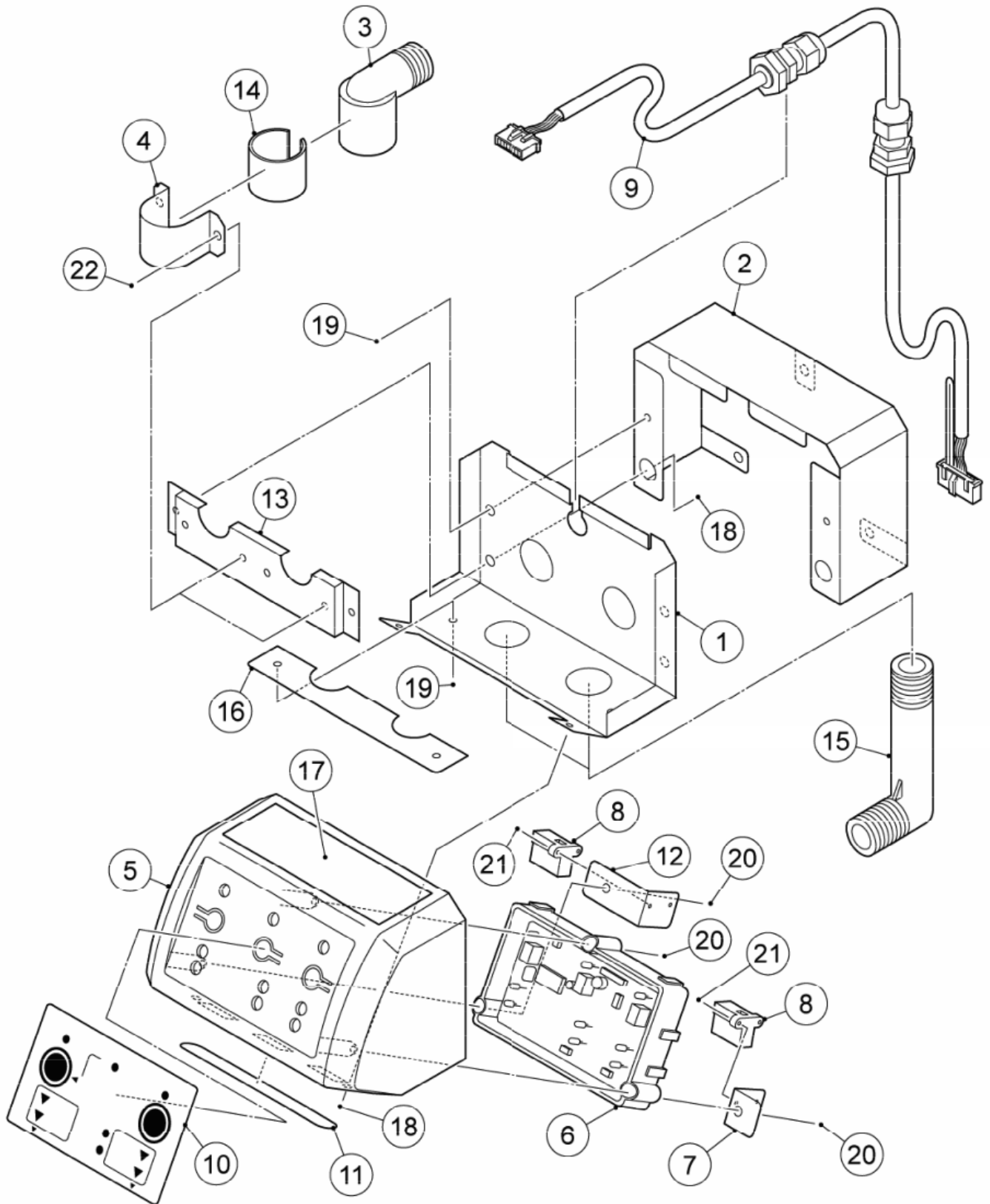

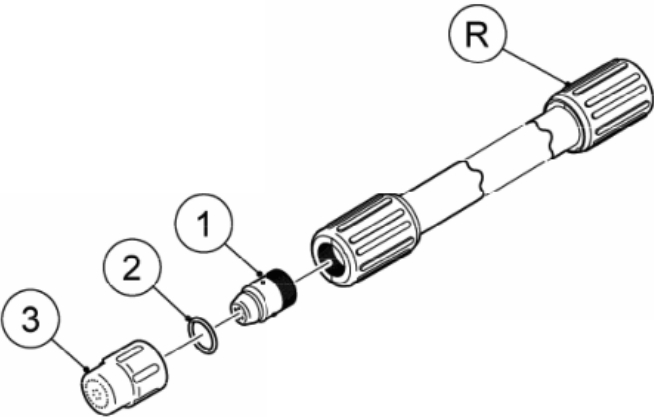

(S-9875)

ROX-20TB2-U

R. NOZZLE ASSY

(A-1) and later

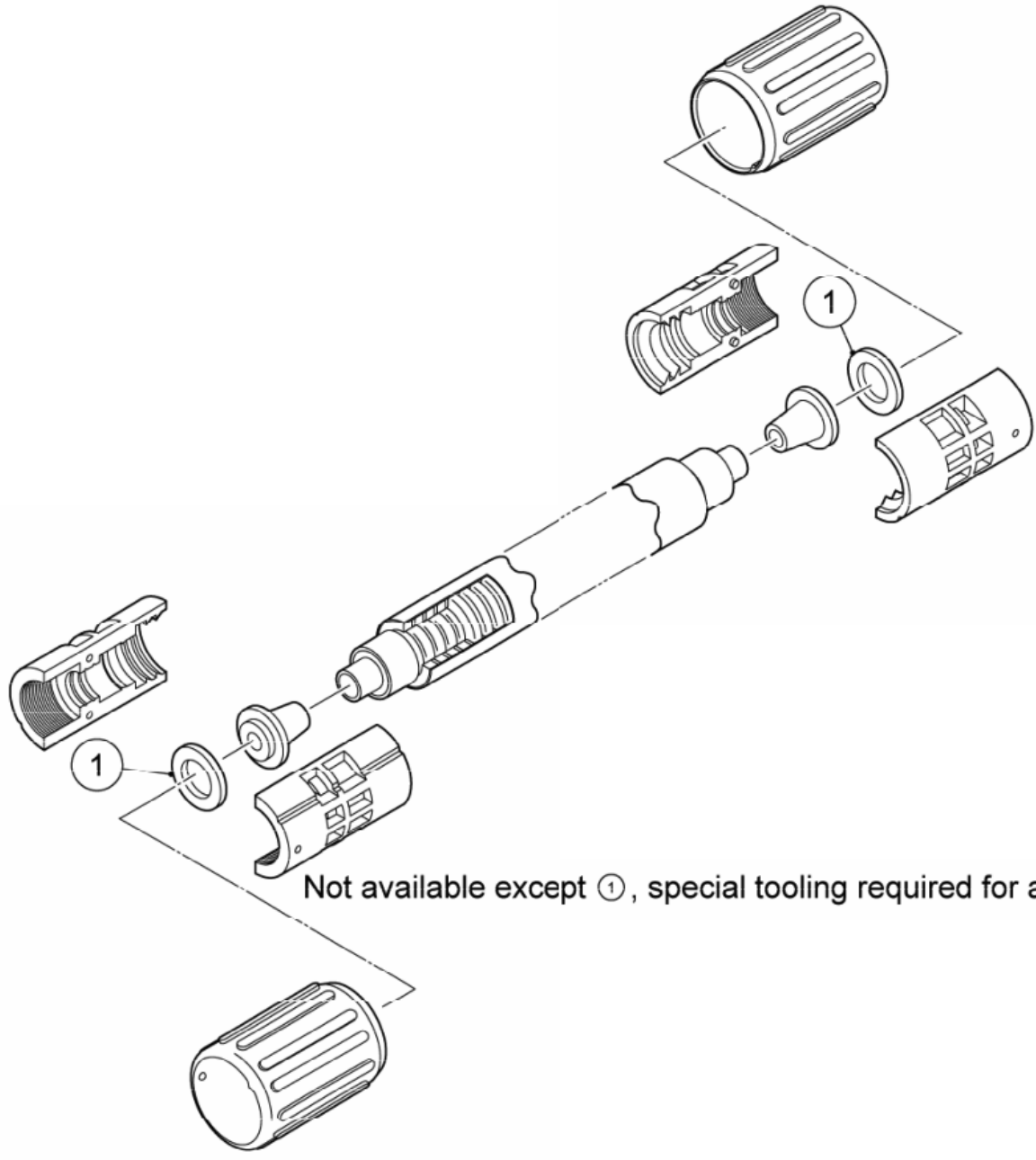

Not available except ①, special tooling required for assembly.

